

Pipelines Monitoring System Using Bio-mimetic Robots

Seung You Na, Daejung Shin, Jin Young Kim, Seong-Joon Baek, and Bae-Ho Lee

Abstract—Recently there has been a growing interest in the field of bio-mimetic robots that resemble the behaviors of an insect or an aquatic animal, among many others. One of various bio-mimetic robot applications is to explore pipelines, spotting any troubled areas or malfunctions and reporting its data. Moreover, the robot is able to prepare for and react to any abnormal routes in the pipeline. Special types of mobile robots are necessary for the pipeline monitoring tasks. In order to move effectively along a pipeline, the robot's movement will resemble that of insects or crawling animals. When situated in massive pipelines with complex routes, the robot places fixed sensors in several important spots in order to complete its monitoring. This monitoring task is to prevent a major system failure by preemptively recognizing any minor or partial malfunctions. Areas uncovered by fixed sensors are usually impossible to provide real-time observation and examination, and thus are dependent on periodical offline monitoring. This paper proposes a monitoring system that is able to monitor the entire area of pipelines—with and without fixed sensors—by using the bio-mimetic robot.

Keywords—Bio-mimetic robots, Plant pipes monitoring, Mobile and active monitoring.

I. INTRODUCTION

BIO-MIMETICS[1, 2] is a study of adopting mechanisms found in natural organisms and applying them in engineering. Living organisms evolved their way to perfection over many centuries, and their mechanisms can be very helpful in the field of engineering; lots of research in bio-mimetics is being done currently in robotics.

Manufacturing plant systems usually have various kinds of machines and a vast length of pipelines. Therefore, there are many kinds of signals that have a large amount of data to be monitored. The monitoring system allows a robot to formulate an appropriate movement or response once it recognizes a malfunction[3]. The monitoring process goes through several steps, including collecting, saving, conditioning and analyzing data. Minor problems, which are both hard to find and hard to reach, are common in factory environments; the monitoring

system is thus plays a very critical and practical role in these environments.

However, monitoring a massive factory area periodically with ease is almost impossible. Also, although noticeable pipeline leakage and blockage are easy problems to confront, many system failures start from a small leakage caused by years of the pipeline's gradual deterioration. A small leakage is difficult to spot simply by monitoring. In this paper, we aim to create a set of robots that is able to collect data, which will prevent missing any obscure leakage and deteriorated pipelines. A set of modules for measurement sensors, navigation, actuators and communication is attached in the robot to give intelligence and a better maneuver for it to collect data.

II. PLANT MONITORING SYSTEM

The monitoring system's appropriate response to finding abnormal conditions in a pipeline is done by collecting, saving, and examining data. Some of the systems that are currently used include DAS (Data Acquisition System), SCADA (Supervisory Control And Data Acquisition System), and MAP (Manufacturing Automation Protocol). These systems collect monitored data and transfer them to a computer through LAN for them to be saved and examined.

The biggest flaw in the conventional monitoring system is that the observed and monitored spots are fixed. It needs to pick the most appropriate area as its standard measuring point, so that it can distinguish what condition is normal and abnormal[4]. Once an abnormal condition is recognized, the robot reports the data to prevent further problems and system failure.

In this paper, the monitoring system adds moveable observatory points in addition to fixed sensors. The moveable observatory points are the robots on the pipelines as explained in section III. The robot is equipped with a set of modules so that it can report the measured data while searching its path autonomously based on the real-time location of the robot. Therefore, the proposed monitoring method has an advantage of active searching due to mobility and instant analysis.

III. BIO-MIMETIC ROBOTS MOVING ON PIPES

Pipe monitoring bio-mimetic robots are used in a factory environment to locate abnormal conditions due to depreciation and deterioration of the factory machines. Working as an assistant to a professional engineer, the robot replaces a person having to directly examine hard to reach areas, such as

S. Y. Na is with the Electronics and Computer Engineering Department, Chonnam National University, Gwangju 500-757 South Korea (corresponding author to provide phone: +82-62-530-1753; fax: +82-62-530-1759; e-mail: syna12@jnu.ac.kr).

Daejung Shin is with ETTRC, Chonnam National University, Gwangju 500-757 South Korea (e-mail: djshin71ha@hotmail.com).

J. Y. Kim, S.-J. Baek, and B.-H. Lee are with the Electronics and Computer Engineering Department, Chonnam National University, Gwangju 500-757 South Korea (e-mail: beyondi@jnu.ac.kr, bhlee@jnu.ac.kr, tozero@jnu.ac.kr).

Acknowledgment: This work was supported by the Second BK21, CNU and the NURI-CEIA, CNU.

pipelines. The robot also works to collect data and react to its sensors. These bio-mimetic robots are not only useful in industrial environments but also in skyscrapers and any buildings that need a checkup. The robot collects enough data to locate troublesome areas and even predict a possible malfunction later on.

The most appropriate environment for this bio-mimetic robot would be a factory pipeline, water supply and drainage, gas pipes, or an air duct. All these areas require a periodic checkup because deterioration is relatively fast and the replacement is extremely costly. Moreover, due to the complexity of the pipelines, it is a much more suitable job for a small, delicate robot than a human to examine the areas.

Therefore, the robot must be able to move freely throughout the pipelines. A suitable type of robot that is able to withstand factory pipeline's condition and structure is equipped with data monitoring system. The measured data of a pipeline are collected and transmitted to a server to find any abnormality such as leakage, vibration, or a temperature change. In order to perform its job properly as a mobile agent, the robot must be built in a proper shape and attached with driving module and interface including a battery pack. Also, a server is necessary to report the exact location of the robot and communicate information to each other.

IV. MOBILE MONITORING SYSTEM

A monitoring system with fixed sensors provides a variety of real-time measurements and observations. It detects a possible leakage and responds immediately once a malfunction has been found.

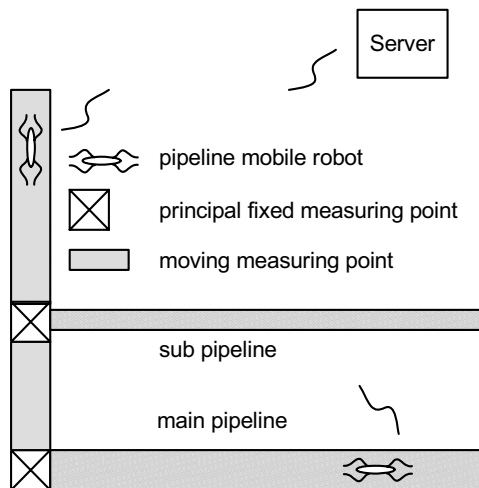

Fig. 1 Schematic diagram of a mobile monitoring system

However, many problems that occur at a pipeline are miniscule and almost undetectable because the problems arise slowly and gradually due to a depreciation of the pipe. In order to cover the entire pipelines and examine each one thoroughly, a huge number of fixed sensors are necessary. One way to replace this costly operation is to have a moving sensor, or a bio-mimetic robot, that will get to some of the places that professional engineers either cannot reach or fail to examine. The bio-mimetic robot is able to perform the pipeline checkup

much faster and more often than an engineer. Moreover, over time the robot is able to use its past data to calculate the speed of the pipelines' gradual deterioration and even predict the possible time of outbreaks.

A. Position Measurement System of Mobile robots on Pipes

In order to calculate the location of a moving robot, important spots including the fixed measuring points are marked with RF tags. The RF tags then create the coordinates that will help locate the robot, which moves at a constant speed while collecting and transferring data. This is done by calculating the distance between a RF tag and the robot using the total time the robot takes to move, excluding any time spent when the robot is stationary.

Fig. 2 depicts a pipeline with attached RF tags that locate the robot's coordinate. These RF tags are positioned in turning areas of the pipes, and are able to report the distance between one tag to the other. As the robot moves at a constant speed and stops to collect data, it recognizes the nearby RF tags and begins to move to the next tag. In practice, there is no difficulty in assuming that the map information of pipe systems for maintained system is available.

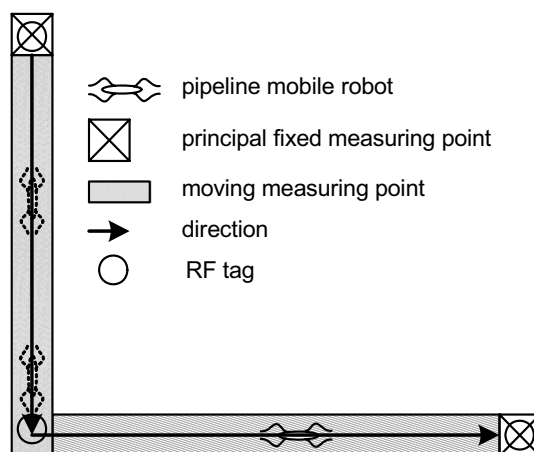

Fig. 2 Position sensing of a mobile robot on pipes

B. Interface Technology of Sensors

The number of pipe conditions the bio-mimetic robot can collect is somewhat limited. It can collect data from about noise, vibration, and temperature; though these may be few, any sudden changes to one of the three conditions would indicate a serious abnormality. A gradual change is also easily detected by the robot unlike a human engineer, since it has a collection of comparable data [5-7].

The level of noise is different throughout the pipelines, but many areas often follow a specific pattern. The periodic patterns of noise over a certain span of time may reveal important clues that are impossible to obtain by real-time assess. In silent areas the robot is able to use its vibration sensor instead. Vibration is one condition that is almost impossible to be analyzed by a human engineer's perception, so the robot's ability broadens what the monitoring system can detect.

The temperature of a surface of a pipe is also important. For a faster and simpler way of measurement, the robot uses infrared rays to measure temperature. As shown in Fig. 3, the four-legged robot includes several sensors.

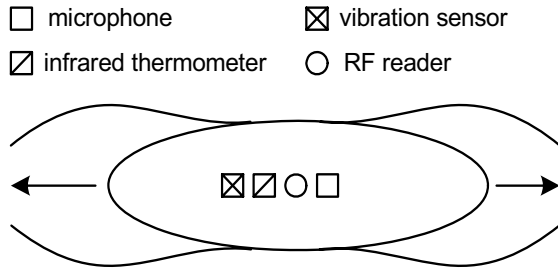

Fig. 3 Sensors of a mobile robot on pipes

C. Pipe Climbing Robots

There has been lots of research on the robots that can move along the walls or pipes in many environments including buildings and large ships. Generally, these types of robots stick to the desired surfaces and move up or down using electromagnets or sucking disks by air flow. Alternatively, a method of moving in the similar way as the man climbs up the tree is used[10,11]. These methods seem to be easy to develop and provide a high level of efficiency. The methods can be very effective in some environments; however, they are not quite practical, especially in complicated environments. The pipe climbing robot is the bio-mimetic robot equipped with holding grippers, which are installed at the end of the four arms. It can grip the pipe and move along the pipe. Once it grabs the pipe in order to move, it uses four arms with 3 DOF joints that can hold the robot body. It operates either automatically or by remote control, and collects and analyzes data before transmitting them to a server. A diagram of microcontroller and peripheral equipment for the robot is shown in Figure 4.

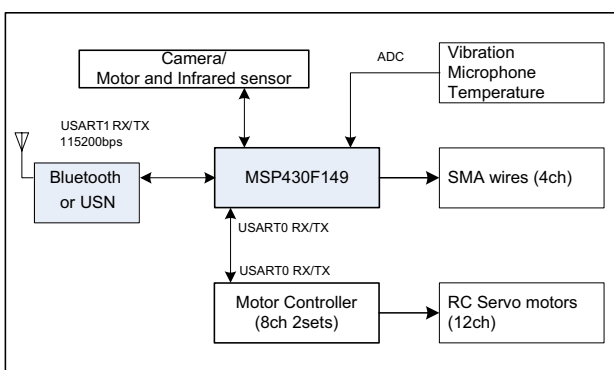

Fig. 4 A functional block diagram of a pipe climbing robot

D. Data Analysis and Fault Diagnosis

While moving along a pipeline, the bio-mimetic robot analyzes its data and transfers to a server. Once an abnormal pattern is detected, it must be able to record the data and send out a possible warning as well as its data. This processing applies to every kind of sensors. For this purpose mobile robots

contain a set of basic signal processing algorithms.

E. Real-time Data Transmission

When in a small facility, the robot can send its data directly to the server system. However, a set of sensor network nodes is necessary at important fixed locations for data transmission and calibration of positional data in a large pipeline system.

F. Distribution of USN Nodes

In a massive area of pipelines, it is too time consuming to rely on a relatively slow mobile robot. For example, in a nuclear plant or a large water supply plant, it is much more efficient to divide its complicated and wide pipelines into several sections, and place a number of bio-mimetic robots to each section. In order to perform the task swiftly, the robots need to be able to work mutually and collectively. Lastly, the collected data from the robots are combined and analyzed as one to pinpoint abnormalities and predict future conditions. Fig. 4 shows a few mobile robots working mutually as a group.

Many industrial environments go through minor errors and malfunctions. Where there are a large number of complex machines and pipelines that go through daily use, even a small deterioration of these materials can eventually lead to not only a costly and large replacement, but also a mass failure. A periodic checkup to detect the deterioration or an abnormality is thus critical, but it is often too difficult to be handled by a human engineer. Using a large number of fixed sensors to cover the area is one way to monitor this problem. However, we believe that using a number of mobile, bio-mimetic robots to move throughout the pipelines is a much faster, cheaper and more efficient solution.

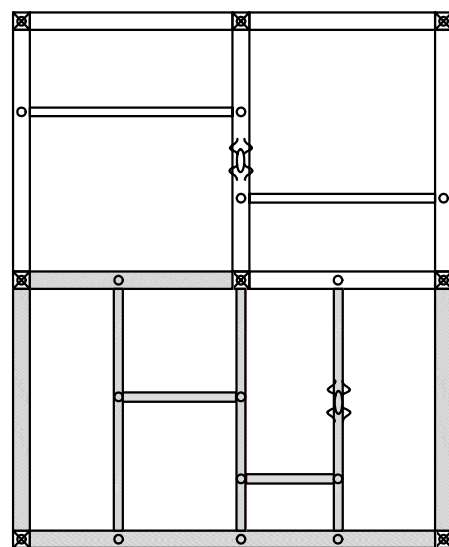
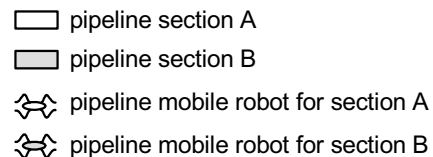

Fig. 5 Distribution of mobile robots on large pipelines

V. CONSTRUCTION OF A MONITORING ROBOT SYSTEM

We present a bio-mimetic robot that is able to collect the data by moving freely along the pipelines. The proposed robot, serving as an assistant to a professional engineer, is the monitoring system which collects and processes the relevant data to find abnormal conditions of the pipeline. These robots are useful especially in large buildings as well as in industrial environments, where complex facilities are operated. The monitoring robot must be able to collect enough data to locate a variety of system failures and preemptively predict and even prevent any possible malfunction in advance.

A. Microcontroller Units

The microcontroller, which works as the robot's main brain, exchanges information and commands with the server by using the Bluetooth module connected to the serial communication ports. To control many servo motors of the robot, one or more than one separate motor controller is used, and other serial communication ports are used to exchange appropriate commands. In that way, the microcontroller is able to avoid heavy load and collect and analyse the sensor data such as vibration, noise and temperature. For the gripper as an implementation device to firmly grip the pipe, a set of relays is used to provide or disconnect the electricity to the shape memory alloy wires. The gripper using the shape memory alloy is located at the end of the four arms of each robot. A microcontroller unit as the role of the robot's brain is depicted in Figure 6.



Fig. 6 A microcontroller unit for a pipe robot

B. Grippers

The end-effectors of the robot which actually hold a grip of the pipe is shown in Figure 7. The gripper consists of the gripping part, the joints, and the shape memory alloy wires used to move the joints. The alloy contracts as the temperature rises when consistent electricity is provided. The contraction of the wire causes the joint to move and makes the ends of the gripper separated from each other. If the electricity is disconnected, the shape memory alloy returns to its normal condition and the gripper grips the pipe by the power of springs which form the joints. Basically, the pipe climbing robot holds a grip of the pipe by spring force when there is no current supply to the shape memory alloy wires. For the robot to move, the gripper moves one of its four arms forward by taking the ends apart and

moving the angle of the joints connected to the servo motor. In order for the moved arm to stick to the pipe, the electricity to the shape memory wire is disconnected. Once the sufficient power to grip the pipe is applied, the other arms are moved either forward or backward of the pipe, in accordance with the given commands. The pipe climbing robot weighs about 570g with the batteries included; at the initial state, the length of the wire is 52mm. While the gripper has the angle of 30°, the angle is 45° when the wire contracts and reaches to 49mm.

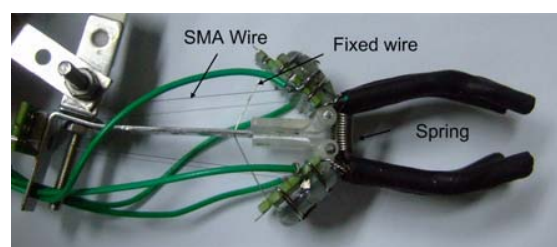
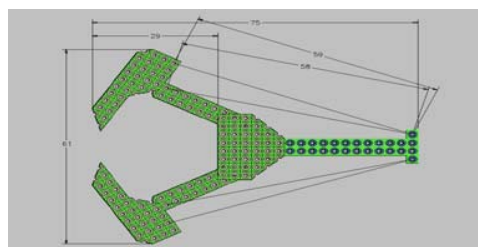
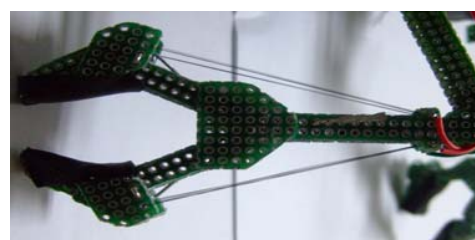

Fig. 7 Gripper structure of a pipe robot

C. Shape Memory Alloy Wires

The elasticity of the spring is strong enough to withstand the weight of the body. To prevent the unnecessary power from adding to the shape memory alloy wires, the fixed wire is used, as shown in Figure 7. The fixed wire sustains the elasticity of the spring at the initial status so that the SMA wires do not be loosened. At this status, the shape memory alloy wire is pulled enough not to allow no additional power so that the highest power can be obtained when contracted.

The shape memory alloy which was used for the robot grippers has the radius of 0.004 inches and it has resistance of about 3 Ω per unit. If the electricity is provided to the alloy, the temperature of the wire rises and there will be about 3-5% contraction. At this time, tension for the unit inch is about 150g. To increase the tension, several wires are used in parallel. The alloy wire, which was used in the experiment, shows the largest contraction at 70°C, and the excessive rise in temperature harms the nature of the shape memory alloy. When expanded by operating the joint motor of the robot, it has the dimension of 320×180×190mm while it has the dimension of 180×160×170mm when contracted.

Two wires of about 10 inches are installed at four places where force is applied. Therefore, each connected wire has the tension that can handle a weight of $150g \times 8 = 1200g$. The set of wires is installed at both ends of each gripper; the total power amounts to approximately 2.4Kg. The entire wire has the resistance of 14Ω , and when the voltage of 5V is given, it has 0.37A and the contraction shows the variation of 15° at one joint of the gripper and indicates about the variation of 30° in total. Figure 7 shows the constructed gripper structure for the pipe climbing robot.

Table 1. Characteristics of Flexinol SMA

Diameter (Inches)	Resistance (Ω /Inch)	Maximum Pull Force (grams)	Approximate Current at Room Temperature (mA)
0.001	45.0	7	20
0.003	5.0	80	100
0.004	3.0	150	180
0.005	1.8	230	250
0.010	0.5	930	1000

D. Body Integration

As the robot moves along the designated routes, it collects data on leakage, vibration, or temperature changes. And then it reports them to the server system. Therefore, the systems should include the proper robot structure, sensors, and the interface with actuator modules, which can resolve the problems with the robot's movement and performance. Since we use robots which move autonomously, the power, location recognition and the communication module with the server are also necessary.

The robot follows the routes according to the rules so that maintenance of the pipelines can be ensured. As it identifies the existence of the pipeline which it needs to move along, the robot has sensors to recognize the complex pipelines.

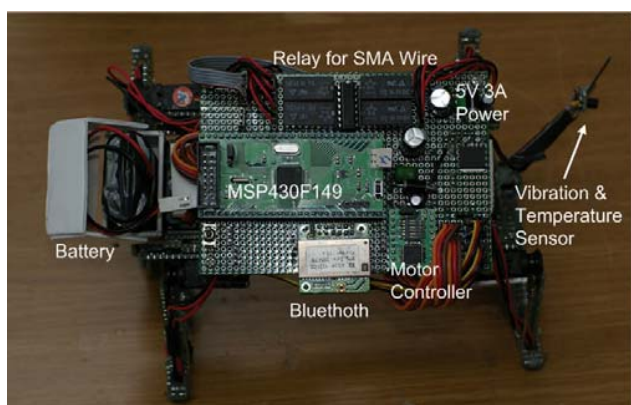

Fig. 8 Integration of functional units for a pipe robot

E. Sensor Module

The conventional methods of pipeline monitoring collect data by sensors attached on fixed posts. The proposed method, however, relies on mobile robots that have a fundamental advantage of mobility over the conventional fixed monitoring posts. Since bio-mimetic robots can move anywhere on the pipes while collecting measurements, it is possible to track directions that have higher possibilities of malfunction in real time modes. Practically this kind of real time dynamic monitoring method is very important in the investigation of possible future failure and protection of plants.

As a typical sensing data for diagnosis, sound data collection of pipelines is described. Many methods of sound source localization have been developed based on audio-visual information [12-14]. The basic features of the sound signals to determine the directions and distances of sound sources are the interaural time difference (ITD) and the interaural level difference (ILD) from a sound source to each microphone.

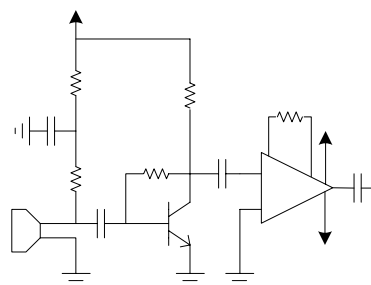

Fig. 9 Circuit of a stereo microphone system

A simple estimation method of sound directions employing only microphones is used due to the restriction of computation time and resources in a mobile robot system. The calculations of the interaural time difference (ITD) and the interaural level difference (ILD) from a sound source to each microphone or the analysis of the average magnitude difference function (AMDF) signals for short-time intervals are not applied to get the estimation quickly. Only sampling of microphone signals, A/D conversion and simple algebraic calculations are applied to obtain the differences of the right and left microphone measurements, which are directly related to the sound directions.

The method of sound direction estimation employed at a microprocessor, which handles a set of functions for an autonomous robot, has the following steps:

1. Sampling left and right microphone raw data $m_l(k)$ and $m_r(k)$
2. A/D conversion using eight bits
3. Getting band pass filtered data $b_l(k)$ and $b_r(k)$ of step 3
 1. Bandwidth for sound signals
4. Getting squared data $s_l(k)$ and $s_r(k)$ of step 3
5. Summing 99 previous samples to current samples of step 4: $S_l(k)$, $S_r(k)$
6. Difference data: $d(k) = S_l(k) - S_r(k)$

The sampling rate of 5KHz is applied to microphone raw data considering the computation time of the microprocessor. Only eight bits of the internal 12-bit A/D converters are used.

The results show quite linear relationship between the sound direction and the indices of the above algorithm. It applies to the sound direction of 180 degrees using only a side pair of microphones. The same algorithm can cover the whole direction when both the side pair of microphones and the forward-backward pair of microphones are used.

In addition to sound data by similar methods, typical signals the monitoring robot collects are acceleration and temperature data associated with possible leakage, vibration, or temperature changes.

F. Noise Rejection

There are two main sources of noise: environmental sound around the robot and noise from actuating motors inside a robot body. Since the main spectrum of the motor noise has much higher range than that of signals from pipelines, it is easy to filter out the effect from the motor sound. However, the sound of environmental noises has a similar spectrum range to that of interested signals. The environment signals are rather uniform around the robot, and the measured signals due to ambient noises are similar at each microphone. Therefore, when the measured signal at the left microphone is subtracted from that of the right one, noise components due to ambient noise are nearly cancelled out. The subtraction can reveal the interested component that arrived at the left and right microphones differently due to different approaching angles.

When the sound direction of the interested signals is estimated, a mobile robot turns its head to the near direction which is possible on the pipelines. Sound distances from the sources to microphones are not estimated because of the randomness of sound source levels.

G. Overall Performance

The pipe climbing robot is the bio-mimetic robot equipped with holding grippers, which are installed at the end of the four arms. It can grip the pipe and move along the pipe. Once it grabs the pipe in order to move, it uses four arms with 3 DOF joints that can hold the robot body as shown in Figure 10. It operates either automatically or by remote control, and collects and analyzes data before transmitting them to a server. The flowchart of commands for motor control and the flowchart for the overall movement of a crawling robot are shown in Figures 11 and 12.

The monitoring probe with several kinds of sensors for the detection of the pipe status is located in front and it measures the corresponding data. The distance values, for instance, are measured by the infrared sensor which moves from left to right and then the other way depending on the angle changes of a rotating motor. This scheme of data acquisition minimizes the load of the microcontroller.

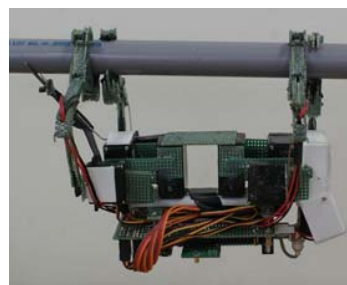
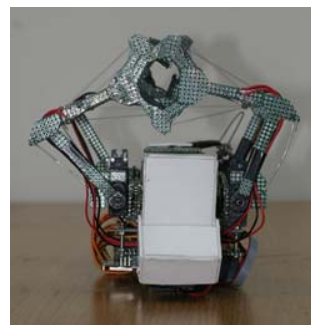

Fig. 10 Pipe crawling robot with a monitoring probe

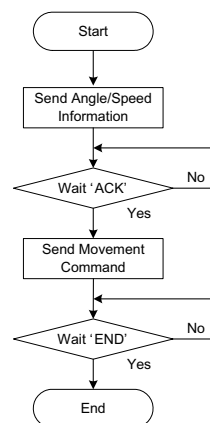

Fig. 11 Flowchart of commands for motor control

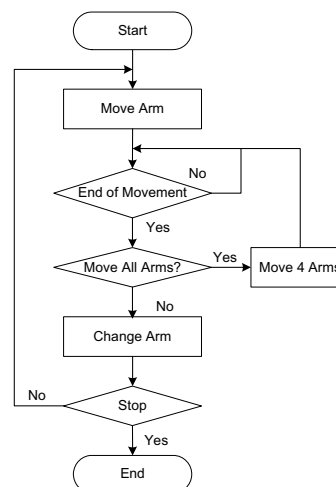

Fig. 12 Flowchart for the movement of pipe crawling robots

H. Data Acquisition and Display

The transmitted sensor data to a server are analyzed and displayed to provide comprehensive information that is associated with a possible malfunction or problems of the pipeline system. The typical arrangement of the transmitted data after filtering and conditioning of the raw sensor signals are shown in Figure 13.

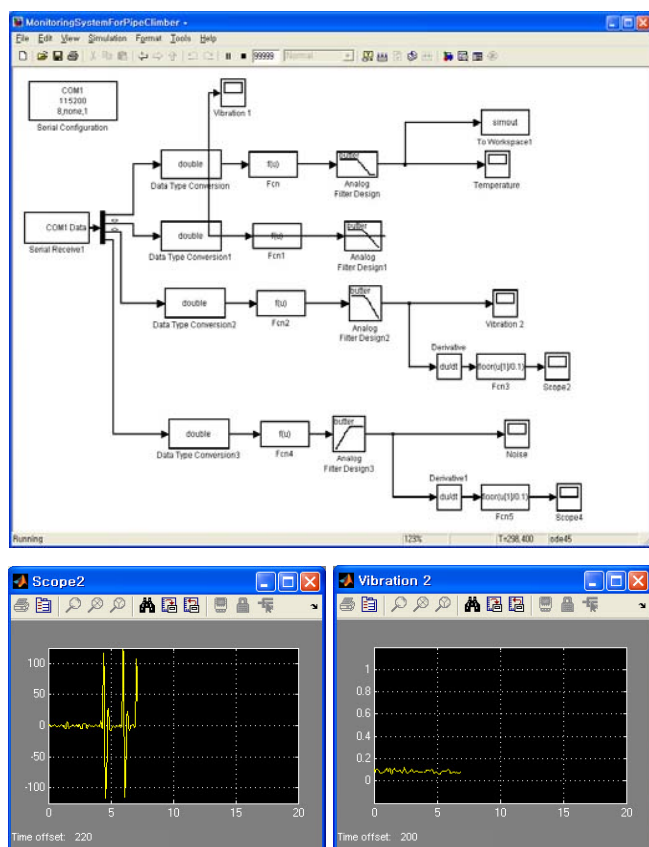

Fig. 13 Sensor data acquisition and display using Matlab

VI. CONCLUSION

A practical solution of exploring pipelines, spotting any troubled areas or malfunctions and reporting its data by mobile bio-mimetic robots is proposed. In order to move effectively along a pipeline, the robot's movement will resemble that of a

typical crawling insect. Areas uncovered by fixed sensors are usually difficult to provide real-time observation and examination. Therefore, this paper provides a practical monitoring system that is able to monitor the entire area of pipelines in an active manner by using the bio-mimetic robots.

REFERENCES

- [1] J. Yu, M. Tan, S. Wang, and E. Chen, "Development of a biomimetic robotic fish and its control algorithm," *IEEE Trans. on Systems, Man, and Cybernetics-Part B*, Vol. 34, pp. 1798-1810, 2004.
- [2] D. Shin, S.Y. Na, J.Y. Kim, and S. Baek, "Water pollution monitoring system by autonomous fish robots," *WSEAS Trans. on SYSTEM and CONTROL*, Issue 1, Vol. 2, 2007, pp. 32-37.
- [3] J. J. Gertler, *Fault Detection and Diagnosis in Engineering Systems*, Marcel Dekker, Inc, 1998.
- [4] L. Lundgard, B. Skyberg, "Acoustic Diagnosis of SF6 Gas Insulated Substations," *IEEE Trans. Power Delivery*, 1990.
- [5] J. Lin and L. Qu, "Feature Extraction Based on Morlet Wavelet and Its Application for Mechanical Fault Diagnosis," *Journal of Sound and Vibration*, 2000, pp. 135-148.
- [6] J. Shao, G. Xie, L. Wang, and W. Zhang, "Obstacle avoidance and path planning based on flow field for biomimetics robotic fish," *AI 2005, LNAI 3809*, 2005, pp. 857-860.
- [7] Ma, Zhanshan, Krings, Axel W., Hiromoto, Robert E., "Dragonfly as a model for UAV/MAV flight and communication controls", *2009 IEEE Aerospace conference*, pp.1-8, 2009.
- [8] Stoianov, I., Nachman, L., Madden, S., Tokmouline, T., Csail, M., "PIPENET: A Wireless Sensor Network for Pipeline Monitoring", *IPSN 2007*, pp. 264 – 273, 2007.
- [9] Changsoo Ok, Thadakamalla, H., Raghavan, U., Kumara, S., Sang-Gook Kim, Xiang Zhang, Bukkapatnam S., "Optimal Transmission Power in Self-sustainable Sensor Networks for Pipeline Monitoring", *IEEE International Conference on Automation Science and Engineering*, pp. 591 – 596, 2007.
- [10] Masataka Suzuki, Shinya Kitai, and Shigeo Hirose, "Basic Systematic Experiments and New Type Child Unit of Anchor Climber: Swarm Type Wall Climbing Robot System", *2008 IEEE International Conference on Robotics and Automation*, pp. 3034-3039, 2008.
- [11] A. Sadeqi, H. Moradi, and M. Nili Ahmadabadi, "A Human-Inspired Pole Climbing Robot", *IROS 2008*, pp. 4199 – 4199, 2008.
- [12] J. Shao, G. Xie, L. Wang, and W. Zhang, "Obstacle avoidance and path planning based on flow field for biomimetics robotic fish," *AI 2005, LNAI 3809*, 2005, pp. 857-860.
- [13] R.J. Mammone, X. Zhang and R.P. Ramachandran, "Robust Speaker Recognition: A Feature-based Approach," *IEEE Signal Processing Magazine*, Vol. 13, No. 5, pp. 58-71, 1996.
- [14] C. Schauer and H.M. Gross, "Model and application of a 360° sound localization system," *Proceedings of the International Joint Conference on Neural Networks*, Vol. 2, pp. 1132-1137, 2001.