

# Integrating Process Planning and Scheduling for Prismatic Parts Regard to Due Date

M. Haddadzade, M. R. Razfar, and M. Farahnakian

**Abstract**—Integration of process planning and scheduling functions is necessary to achieve superior overall system performance. This paper proposes a methodology for integration of process planning and scheduling for prismatic component that can be implemented in a company with existing departments. The developed model considers technological constraints whereas available time for machining in shop floor is the limiting factor to produce multiple process plan (MPP). It takes advantage of MPP while guaranteed the fulfillment of the due dates via using overtime. This study has been proposed to determinate machining parameters, tools, machine and amount of over time within the minimum cost objective while overtime is considered for this. At last the illustration shows that the system performance is improved by as measured by cost and compatible with due date.

**Keywords**—Due date, Integration, Multiple process plan, Process planning, Scheduling.

## I. INTRODUCTION

PROCESS planning is a function in a manufacturing organization that selects the manufacturing processes and process parameters to be used to convert a part from its initial design to the final form. Process planning is therefore the function of the link between design and manufacturing. The outcome of process planning is the information for manufacturing processes and their parameters, and the identification of the machines, tools, and fixtures required to perform those processes.

Computer automated process planning (CAPP) systems developed in the past decade that were intended to bridge the gap between CAM and CAD, to provide fast feedback to designers regarding detailed manufacturing information (e.g., manufacturability) and related cost estimation, and to substantially reduce product development cycle time. These systems, in general, are generative in nature and are often constructed as knowledge-based systems. Most of these systems are capable of generating numerous feasible alternative process plans which a good plan is chosen

according to some established criterion. These systems usually only look at one-way (upstream) and often static (offline) integration with the CAD function.

Scheduling is defined as the allocation of resources over time to perform a collection of tasks. The objective of scheduling is to assign specific task to specific machine in order to balance load distribution among different machines so that the available machines can be effectively utilized. This enhances efficiency and effectiveness of the machine shop [1].

Therefore scheduling begins with a process sheet, where process planning ends. Traditionally, process planning and scheduling have been performed sequentially, a process plan being generated before scheduling is performed. Although this method may be simple, it ignores the inherent relationship between process planning and scheduling.

The scheduling module assumes the process plan to be fixed, and attempts to allocate the resources and to sequence the operations such that the plan is followed. Almost all CAPP systems assume that the shop floor is idle, and that there are unlimited resources on the shop floor. By assuming that scheduling takes over once the process plan is determined, the possible alternative schedules using alternative machines are ignored. Status of the job shop resources is not considered during the process plan generation. This may lead to under or over utilization of certain machines. As a result, completion times of products may be delayed [2]. Investigations have shown that 20–30% of the total shop load in a given period has to be altered to attain the desired output target [3]. This shows the necessity of integrating process planning with scheduling. The present work discusses an approach to integrate process planning with scheduling in a job shop environment for prismatic components when multiple process plan (MPP) for each part type are available. The proposed approach takes advantage of MPP such as flexibility while guaranteed the fulfillment of the due dates with respect to available time for machining in shop floor.

## II. LITERATURE REVIEW STAGE

Existing CAPP systems fail to incorporate scheduling while generating a process plan and continues based on what is the best way to produce a given part under desired current resource configuration assuming all resources are available at all times. On the other hand changes that occur during the implementation of process plan due to occurrences of certain unpredictable events, such as bottleneck machines, non-

M. Haddadzade., is a member of committee of Society of Manufacturing Engineering of IRAN (corresponding author to provide phone: +98-913-3580356; fax: +98-351-6240030; e-mail: haddad@aut.ac.ir).

M. R. Razfar is an Assistant professor in the Department of Mechanical Engineering (Manufacturing division) at Amirkabir University of Technology (Tehran polytechnic), Tehran Iran (e-mail: razfar@aut.ac.ir).

M. Farahnakian is MSc student in the Department of Mechanical Engineering at Amirkabir University of Technology (e-mail: farahnakian@aut.ac.ir).

availability of tools and personnel [4-6], are usually not fed back to the process planning function and therefore not taken into consideration by the process planning function for modification. This shows the necessity of integrating process planning with scheduling.

Many researchers have attempted contributions to integrate process planning with scheduling. Larsen and Alting [7] categorize the various approaches to the integration of process planning and scheduling into three types. The first, non-linear process planning (NLPP) or flexible process planning was used by number of researchers [8-10]. In this approach, the planning system generating and ranking all possible alternative plans based on some criteria (such as minimum total machining time, minimum total production cost), that called multiple process plans (MPP). This plans stored in a process planning database. The first priority is always ready for submission when the job is required and then scheduling makes the real decision. If the first priority plan does not fit well in the current status of the shop floor, the second priority plan will be provided for the scheduling. This procedure is repeated until a suitable plan is identified from already generated process plans [10].

Making use of alternative process plans will create a new dimension for scheduling. Conventionally, scheduling may be viewed as a planar (2-dimensional) scheduling where job (or machine) and time are the two axes while using MPP can be analogized as a 3-dimensional scheduling where the three axes are job, method and time [11].

The second approach, closed loop process planning (CLPP) generates plans by means of a dynamic feed back from the shop floor with respect to the status of the resources at that time [12]. The major disadvantage of this approach is that the process planning and scheduling departments in a company may have to be dismantled and reorganized to take full advantage of CLPP approach.

The last approach, distributed process planning (DPP), involves performing planning and scheduling activities simultaneously. It divides the process planning and production scheduling tasks into two phases. The first phase is preplanning and the second phase is the final planning. IPPM [13] and later IPPS [14] are examples of such systems.

The foregoing review reveals that DPP is the best approach for integration of process planning and scheduling. However, this approach requires high capacity and capability from both hardware and software. Also planning and scheduling departments in a company have to be completely dismantled and reorganized in DPP and CLPP. In NLPP, process plans contain alternative routings, which offer high degree of flexibility to scheduling. Moreover, NLPP can be implemented in a company with existing process planning and scheduling departments and without any reorganization of them. But in all the reported researches when process plan are ranked, the optimal cutting conditions are calculated separately for each elementary machining operation required to generate the final part. Depending on the approach, the objective functions are the machining cost and the machining

time (or some hybrid combination of both). The workstation loading conditions or the available time at the machine tool were never been considered. Only Henriques [15] considered this conditions that it's failed with overtime.

This paper proposes a new method for integrating scheduling with process CAPP that optimizes cutting parameters for milling operations that calculates simultaneously the cutting speed, feed rate, radial and axial depth of cut within the minimum cost objective while overtime was considered for this, to compatible with due date. It can be implemented in a company with existing process planning and scheduling departments when MPP for each part are available.

### III. METHODOLOGY

The proposed integrated model composed two modules, the process planning module and scheduling module. Process planning module generates all possible alternative plans then scheduling module ranked these based on minimum cost while the due date was considered Fig. 1.

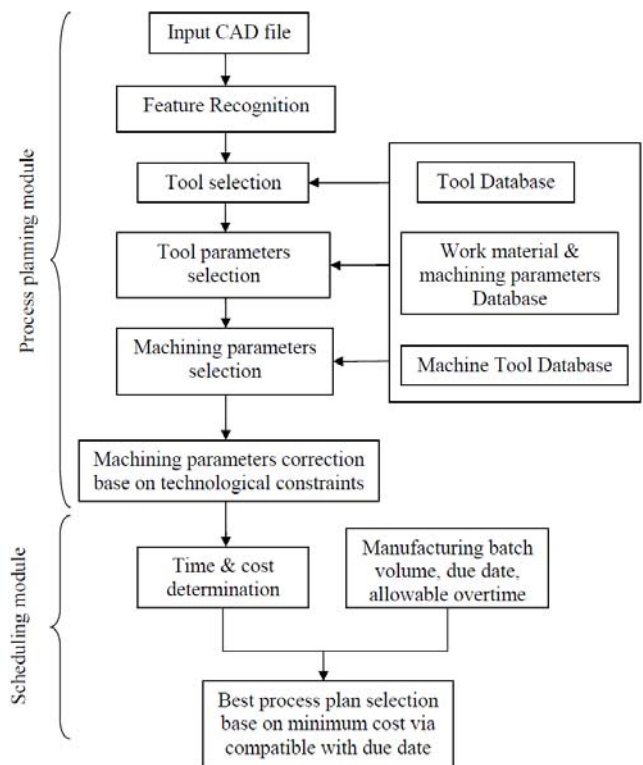

Fig. 1 Flowchart of integrated model

At first, the necessary information was gathered from CAD file such as feature type include face milling, square shoulder face milling, slot milling, pocket milling, chamfered-circle milling, long-edge milling and chamfered-angle milling (Fig. 2), feature geometries, tolerance and surface finish and with interface by user (such as manufacturing batch volume and due date). The process planner module interacts with a database to extract the values of nominal machining

parameters for roughing and finishing operations. Furthermore, the machining parameters are subjected to a great number of technological constraints to the part material and geometry, to the machine tool and the quality of the tool used. Another database is used to consider machine tool related constraints.

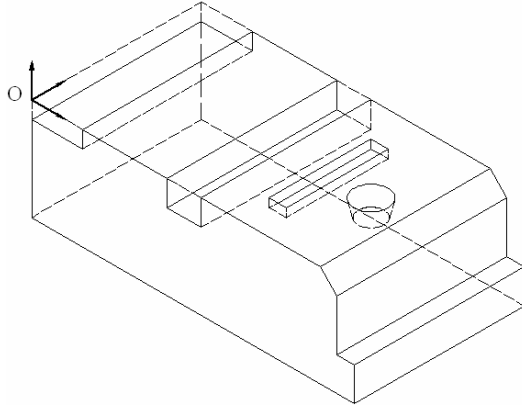

Fig. 2 A prototype component

Below a certain depth of cut, the metal compresses instead of forming chips and will spring back when the tool has passed with a very low feed rate, an abrasive forming will result instead of a chip forming process. There are also above a certain value of feed rate, the tool wear process changes and the crater wear because the dominant factor instead of the flank wear [16]. Therefore there are upper and lower limits of the depth and feed ratio to allow a good chip formation.

Most researchers agree that the main cause of surface roughness is due to feed tool marks therefore the maximum feed imposed by the maximum roughness specified is as follow:

$$f_z = \frac{\sqrt{R_a \cdot D}}{0.2533 \cdot z} \quad (1)$$

where  $R_a$  is the value of surface roughness,  $z$  is number of teeth on the tool,  $D$  is tool diameter and  $f_z$  is feed rate per tooth.

Also maximum depth of cut is limited as a function of material hardness and surface roughness:

$$a_{p\max} = \frac{32R_a}{BHN^{0.8}} \quad (2)$$

Other considered constraints, related part, tool and machine tool are presented in Table I.

TABLE I  
 OTHER TECHNOLOGICAL CONSIDERED CONSTRAINTS

Constraint	Imposed criteria
$a_p < \frac{2}{3} L_{ins} \cdot \sin \kappa$	Cutting edge length and the tool approach angle
$a_p < a_w$	Maximum stock to remove
$\frac{\pi D N_{\min}}{1000} < v < \frac{\pi D N_{\max}}{1000}$	Limits of spindle speed
$f_{\min} < f < f_{\max}$	Limits of table feed

$P_c = \frac{a_p \times a_e \times v_f \times K_c}{60 \times 10^6 \times \eta}$	Limits of machine power
$D > (1.2 - 1.5) \times a_e$	(preferential criteria) for Face Milling
$D \leq B$	Obligatory criteria for Pocket and Slot Milling
$\sum t_i \leq t_{\max}$	Allowable time for machining

An integrated process planning and scheduling reveals the necessity of cutting conditions optimization to the objective of minimum cost, since it is necessary to consider not only the technological constraints, but also a time constraint dictated by the shop floor management (not only minimum time), therefore it must be exactly define the maximum available time for the job. Within this context, the model can be mathematically formulated as follow. For each operation, maximum available machining time is calculated:

$$t_{\max} = \frac{T_t + T_o - T_s}{N} - T_l - T_{ch} \quad (3)$$

where  $t_{\max}$  is maximum available time for machining,  $T_t$  is available time to compatible with due date,  $T_o$  is overtime,  $T_s$  is machine tool setup time,  $N$  is manufacturing batch volume,  $T_l$  is time for loading and unloading of each part and  $T_{ch}$  is tool changing time.

Necessary overtime can be calculated as follow (if machining time becomes larger than available time without overtime):

$$T_{on} = (T_m - T_{wo}) \times N \quad (4)$$

where  $T_{on}$  is necessary overtime,  $T_m$  is the machining time and  $T_{wo}$  is maximum available time for machining without overtime consideration.

The following formula can be used to determine of the average cost of the component:

$$C_{pw} = [C_m \cdot (T_l + T_m + T_m / T_c \cdot T_{ich} + T_s / N_w + T_{ch}) + (T_m / T_c \cdot C_t)] \quad (5)$$

where  $C_m$  is labor and overhead costs,  $C_t$  is the cost of tool with indexable inserts includes cutter body depreciation and the cost per cutting edge,  $T_{ich}$  is time for changing one insert,  $T_c$  is tool life for minimum production cost

The machining time for milling operations can be calculated using

$$T_m = (L_w + D) \cdot n_p / n \cdot z \cdot f_t \quad (6)$$

where  $L_w$  is the length of feature,  $n_p$  is the number of passes and  $n$  is the spindle speed.

If it was needed to use overtime the labor and overhead costs must be modified as follow:

$$C_{mo} = \frac{T_{st} \times C_m + T_{on} \times C_o}{T_s + T_{on}} \quad (7)$$

where  $T_{st}$  is standard time per day and  $C_o$  is the labor and overhead costs in overtime.

#### IV. ILLUSTRATION

To evaluate the benefit of proposed model, a job shop with four machines was considered (Table II). It is assumed that

100 workpieces must be produced after 3 days. Therefore 22.5hrs is available that 40min would consumption for machine tool setup and 2 min would consumption for workpiece loading and unloading and 1 min for tool changing. According to Eq.3 and surrender of over time, there is 10.1min for machining of each part while with 1.5hrs overtime per day this time become 12.8min for each part.

TABLE II  
MACHINE TOOL SPECIFICATION

Machine Tool	Max Power	Max Diameter	Max Feed	Max rpm	Cost
FP4MB	3.7	200	3000	3150	0.6
FP4MC	6	250	3000	3150	0.8
FU450R	3.7	200	630	2500	0.5
VMC850	7.5	100	12000	8000	1.3

The outputs of model are such as Table III. The process plans are ranked base on minimum cost. The first priority is not executable because it is not compatible with due date. Also second priority isn't possible if the overtime do not consider and third priority would be selected whereas with proposed approach, the second priority was executable with 1hr overtime per day and lead to 14.26% decrease in cost.

TABLE III  
OUTPUTS OF PROCESS PLANNER MODULE

Machine Tool	Cm (\$)	Co (\$)	Tm (min)	Tc (min)	Ct (\$)	Cpw (\$)
FU450R	0.5	0.55	13.1	108	10.7	7.97
FP4MB	0.6	0.69	11.9	78	12.3	9.38
FP4MC	0.8	0.9	10	85.1	23.4	10.94
VMC850	1.3	1.42	6.5	69	28	11.33

## V. CONCLUSION

The concept of integration of process planning and scheduling function is a paradigm shift for most manufacturing organization.

In this paper a new methodology was proposed to integrate process planning and scheduling with MPP that can be implemented in a company without dismantling and reorganizing existing departments. This study has been proposed to determinate machining parameters, tools, machine and amount of over time within the minimum cost objective that influenced by technological constraints, cost criteria and due date. The illustration shows that the proposed methodology, improved system performance as measured by cost and compatible with due date.

## REFERENCES

[1] T.W. Liao, E.R. Coates, F. Aghazadeh, L. Mann, and N. Guha, "Modification of CAPP systems for CAPP/scheduling integration", *J Comp. Ind. Eng.* Vol. 25 No.1, pp. 203–206, 1993.

[2] N. Morad and A. Zalzal (1999) "Genetic algorithms in integrated process planning and scheduling". *J Intell Manuf* vol. 10, pp.169–179.

[3] J. Detand and K. U. Leuben, "The generation of non-linear process plans", The 22nd CIRP International Seminar on Manufacturing System, Section 2, 1990.

[4] G. Chryssolouris and S. Chan, "An integrated approach to process planning and scheduling", *Ann. CIRP* 34 (1), 1985.

[5] W.H.M. Zijm, "The integration of process planning and shop floor scheduling in small batch part manufacturing", *Ann. CIRP* 44 (1) (1995).

[6] M. Kumar and S. Rajotia, "Integration of scheduling with computer aided process planning. *J Mater Process Technol* vol. 138, pp. 297–300, 2003.

[7] N.E. Larsen and L. Alting, "Dynamic planning enriches concurrent process and production planning". *Int J of Production Research*, vol. 30, No. 8, pp. 1861–1876, 1992.

[8] H.K. Tonshoff, U. Beckendorff and N. Andres. "FLEXPLAN: A concept for intelligent process planning and scheduling". CIRP International Workshop, Hannover, Germany, September, pp. 21–22, 1989.

[9] G. Chryssolouris, K. Dick, and M. Lee, "Short interval scheduling for discrete parts manufacturing". *Int J Comput Integr Manuf.* vol. 4, pp. 157–168, 1991.

[10] A. Jain, P.K. Jain and I.P. Singh "An integrated scheme for process planning and scheduling in FMS" *Int J Adv Manuf Technol* vol. 30, pp. 1111–1118, 2006.

[11] W. Tan, and B. Khoshnevis, "Integration of process planning and scheduling- a review". *J. of Intell Manu* vol. 11, pp. 51-63, 2000.

[12] B. Khoshnevis, and Q. Chen, "Integration of process planning and scheduling functions". *Journal of Intelligent Manufacturing*, vol. 1, pp. 165–176, 1990.

[13] H.C. Zhang, "IPPM—a prototype to integrate process planning and job shop scheduling functions". *Annals of the CIRP*, vol. 42(1), pp. 513–518, 1993.

[14] S.H. Huang, H.C. Zhang and M.L. Smith, "A progressive approach for the integration of process planning and scheduling. *IIE Transactions*, vol. 27, pp. 456–464, 1995.

[15] E. Henriques, "Towards the integration of process and production planning: an optimization model for cutting parameters". *Int J Adv Manuf Technol* vol. 28, pp. 117–128, 2006.

[16] G. Halvei and R.D. Weil, "Principles of process planning". Chapman & Hall, pp. 170-171, 1995.

**Mohammad Haddadzade** was born at 1984 in Tehran and is a design engineer at Tauli Sanat Bahabad where he handles a variety of design works including machining line layout design, process planning, cutting tool selection and fixture design. Prior to joining the company, he was a visiting lecturer at Sadoughi College. He received his BS from Isfahan University of Technology and MS degree from Amirkabir University of Technology (Tehran Polytechnic). He is a member of committee of Society of Manufacturing Engineering of Iran. His research interests include feature technology, CAPP, machining applications and Scheduling.

**Mohammad Reza Razfar** is an Assistant professor in the Department of Mechanical Engineering (Manufacturing division) at Amirkabir University of Technology (Tehran polytechnic), Tehran Iran. He earned his PhD in 1994 from Mechanical Engineering Department, Sheffield University, UK. His research areas cover, computer aided process planning and manufacturing, feature technology and machining operations and applications of AI and expert systems. He has held various faculty positions at the university and the department and is currently leading the Machining research laboratory. He is a founder and a member of executive committee of Society of Manufacturing Engineering of Iran. He also has extensive engineering experience in industry in the area of production engineering.

**Masoud Farahnakian** was born at 1985 in Isfahan and is a manufacture engineer at Samim Rayaneh where he handles a variety of manufacture works. He received his both BS and MS degrees from Amirkabir University of Technology (Tehran Polytechnic). His research interests include feature technology, CAPP, expert system, machining applications and Scheduling. He is a member of committee of Society of Manufacturing Engineering of Iran.