

# Optimal Sizing of a Hybrid Wind/PV Plant Considering Reliability Indices

S. Dehghan, B. Kiani, A. Kazemi, A. Parizad

**Abstract**—The utilization of renewable energy sources in electric power systems is increasing quickly because of public apprehensions for unpleasant environmental impacts and increase in the energy costs involved with the use of conventional energy sources. Despite the application of these energy sources can considerably diminish the system fuel costs, they can also have significant influence on the system reliability. Therefore an appropriate combination of the system reliability indices level and capital investment costs of system is vital. This paper presents a hybrid wind/photovoltaic plant, with the aim of supplying IEEE reliability test system load pattern while the plant capital investment costs is minimized by applying a hybrid particle swarm optimization (PSO) / harmony search (HS) approach, and the system fulfills the appropriate level of reliability.

**Keywords**—Distributed Generation, Fuel Cell, HS, Hybrid Power Plant, PSO, Photovoltaic, Reliability.

## I. INTRODUCTION

THE contribution of distributed generation units (DGs) in electric power systems have been dramatically increasing in the last decades due to fuel costs and environmental issues while rapid industrialization process and population growth have been resulted in an escalation in the electric power consumption. Since lots of remote areas around the world cannot be technically or economically connected to an interconnected electric power grid, the electricity demand in the aforementioned areas is usually furnished by isolated wind turbine (WT) and/or photovoltaic plants (PV).

Electric Power Research Institute's (EPRI) study predicts that 25% of the new generation capacity will be distributed by 2010 [1]. Additionally, the motivations of electricity market to promote DG all over the world reveal that the mentioned number will grow gradually. Essentially, distributed generation is an electric power source that is connected directly to the distribution network [2]. CIGRE defines DG as the generation, which has the following characteristics: It is not centrally planned; It is not centrally dispatched at present; It is usually connected to the distribution network; It is smaller than 50–100 MW [3].

Some accessible DG technologies are wind turbines, PV arrays, fuel cells, combustion gas turbines, micro turbines, and reciprocating engine. Each one of the mentioned technologies

has its own advantages and drawbacks. Among all the DG, fuel cells are technology of the future while there are some prototype demonstration projects [2].

This is informative that DG can be used either as a stand-alone unit to supply the electric power consumption of a specific area or as a part of an interconnected power system to supply a portion of its electric power demand. DG could be considered as one of the feasible opportunities to take pressure off some of the problems (e.g. high loss, low reliability, poor power quality, congestion in transmission system) faced by the power systems, apart from meeting the energy demand of ever growing loads [2].

Despite the advantages of renewable energy sources in comparison with non-renewable energy sources, investigation results predict that the share of fossil energy sources will be more than renewable energy sources over the course of the next two decades [4]. There are lots of reasons involving this fact such as: lower fuel costs of fossil energy sources in contrast with investment cost of renewable energy sources, and higher reliability of non-renewable energy sources in contrast with renewable energy sources because of the unpredictable climate conditions and/or operation regime of DG units. Therefore, the utilization of renewable energy sources to enhance the system reliability can be a two-edged sword [2]-[4].

An appropriate plan to enhance the economic efficiency of renewable energy plants is the utilization of hybrid schemes such as wind and/or solar energy with existing fuel cells. The addition of energy storage to a small isolated system can enhance system reliability and reduce the adverse operating characteristics associated with systems without storage [5].

Since the generated power of these energy sources is unpredictable, the capacity of these plants and their storage systems should be greater than the load demand to increase the system reliability. In a hybrid generation system, a combination of several energy sources increases the system capability to supply the energy demand of power grid. Therefore, the correlation between wind and solar energy sources will lead to the reduction of plant and its storage system capacities.

Energy storage system can store electric power in the hours that generation is more than consumption and deliver it to power system in the peak hours. A great advantage of storage systems is quick response to temporary oscillations of consumed or generated energy. Additionally, energy storage system can enhance system reliability [5].

S. Dehghan, A. Kazemi, A. Parizad are with the Department of Electrical Engineering, Iran University of science and Technology, 16844, Tehran, Iran ([shahab.dehghan@ieec.org](mailto:shahab.dehghan@ieec.org)).

B. Kiani is with the Green Research center, Iran University of Science and Technology, 16844, Tehran, Iran (e-mail: [kiyani@iust.ac.ir](mailto:kiyani@iust.ac.ir)).

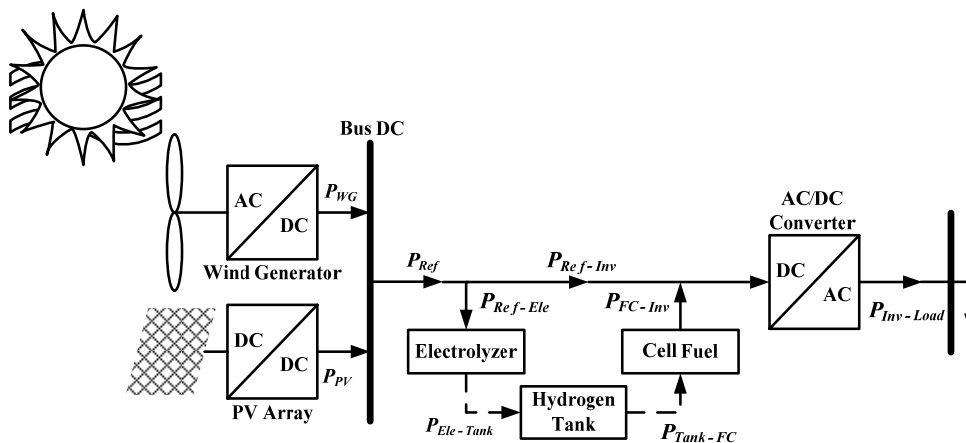

Fig. 1 A hybrid Wind/PV plant with hydrogen energy storage system

In the plants connected directly to the power grid, with the aim of injecting more power to the network (for instance in a wind farm) [6], optimization problem is only optimal sizing and allowing renewable plants while in a hybrid power plant, which is a combination of different units, optimization problem is more complicated than the first one. In this case, the delivered power of wind turbines, PV arrays, and energy storage systems associated with existing conditions of wind direction and solar radiation must be calculated when the investment costs are minimized and the load pattern of power system has been fulfilled considering the appropriate reliability level [7]-[8].

This paper can be outlined as follows. First, the configuration of a hybrid power plant is demonstrated. Second, a specific reliability index is considered to evaluate the system reliability level (i.e. Equivalent Loss Factor). Third, a hybrid PSO/HS procedure is proposed to gain the optimal size of the hybrid power plant. Finally, the results of proposed scheme are tabulated while the hybrid power plant is employed to supply the IEEE reliability test system (RTS) load pattern.

## II. HYBRID SYSTEM CONFIGURATION

Wind turbines and photovoltaic arrays can be broadly used to furnish the energy demand of remote areas. Due to mutual supplementary characteristics of these plants, they can be applied as a hybrid power plant (HPP). A hybrid power plant with a fuel cell energy storage system is outlined in Fig. 1.

According to Fig. 1, in this scheme a combination of a fuel cell, an electrolyzer, and a hydrogen storage tank has been used. In principle, a fuel cell operates like a battery. Unlike a battery, a fuel cell does not run down or require recharging. It will produce energy in the form of electricity and heat as long as fuel is supplied.

Because of non-continuous characteristic of wind blow and solar radiation, the challenging task is to plan a hybrid wind/PV plant which can supply the electricity demand in a reliable manner considering associated operation and investment costs.

### A. PV Array

The radiated solar power on the surface of each PV array can be converted to its output electric power by applying the following equation:

$$P_{PV} = \frac{G}{1000} \times P_{PV,Rated} \times \eta_{PV,Conv} \quad (1)$$

where,  $G$  is the perpendicular radiated power on the surface of each array ( $W/m^2$ ), and  $P_{PV,Rated}$  is the rated power of each array, such that  $G = 1000 W/m^2$ . Also,  $\eta_{PV,Conv}$  is the efficiency of DC/DC converter between each array and DC bus.

While the vertical and horizontal components of the solar radiated power are available for any instant, the radiated power on the surface of each array with a certain angle (for instance  $\theta_{PV}$ ) can be calculated as follows:

$$G(t, \theta_{PV}) = G_V(t) \times \cos(\theta_{PV}) + G_H(t) \times \sin(\theta_{PV}) \quad (2)$$

where,  $G_V(t)$  and  $G_H(t)$  are the rate of vertical and horizontal radiations in the  $t^{th}$  step-time ( $W/m^2$ ), respectively.

Since application of maximize power point tracking (MPPT) system from an economical viewpoint is useful, this logic have been used in the considered test system. The rest of requiring data are as follows [9]:

- Rated power of each PV array: 1 kW
- Investment cost: 7000 \$/unit
- Replacement cost: 6000 \$/unit
- Annual cost of maintenance and repair: 20 \$/unit.yr
- Lifetime: 20 yr
- Forced outage rate (FOR) [10]: 4%

### B. Wind Turbine

The output power of wind turbine with respect to wind speed, which is used in this paper, is depicted in Fig. 2. The rated power of this turbine is 7.5 kW, and its rated output voltage is 48 V. The characteristic of output power  $P_{WG}$  with respect to wind speed can be approximated as follows [9]:

$$P_{WG} = \begin{cases} 0 & ; v_{Cut\ Out} \leq v_W, v_W \leq v_{Cut\ In} \\ P_{WG, max} \times \left( \frac{v_W - v_{Cut\ In}}{v_W - v_{Cut\ In}} \right)^m & ; v_{Cut\ In} \leq v_W \leq v_{Rated} \\ P_{WG, max} + \frac{P_{Furl} - P_{WG, max}}{v_{Cut\ Out} - v_{Rated}} & ; v_{Rated} \leq v_W \leq v_{Furl} \\ \times (v_W - v_{Rated}) & \end{cases} \quad (3)$$

where,  $v_{Cut\ In}$ ,  $v_{Cut\ Out}$ , and  $v_{Rated}$  are the cut-in, cut-out, and rated speed of turbine (m/s), respectively. Also,  $P_{WG, max}$  is the maximum output power of turbine (kW), and  $P_{Furl}$  is the output power at cut-out speed. In this paper  $m$  is considered equal to 3.

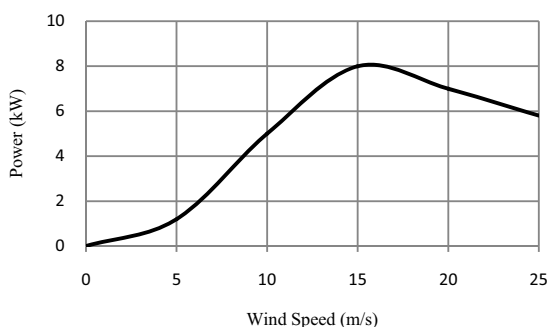

Fig. 2 Power curve with respect to wind speed

It is informative that the wind speed data have been acquired at the 40 m height, while the installation height of considered turbines is 15 m. The wind speed at the installation height can be calculated by the following equation:

$$v_W^h = v_W^{Ref} \times \left( \frac{h}{h_{Ref}} \right)^\alpha \quad (4)$$

where,  $v_W^h$  is the wind speed at a specific height, and  $v_W^{Ref}$  is the wind speed at the reference height expressed in meters per second. Also, the exponent of aforementioned equation,  $\alpha$ , is usually from 0.14 to 0.25 (in this case  $\alpha = 0.14$ ). The rest of requiring data are as follows [9]:

- Rated power: 7.5 kW
- Cut-in speed: 3 m/s
- Cut-out speed: 25 m/s
- Maximum output power: 8.1 kW
- Output power at the cut-out speed: 5.8 kW
- Investment cost: 19400 \$/unit
- Replacement cost: 15000 \$/unit
- Annual cost of maintenance and repair: 75 \$/unit.yr
- Lifetime: 20 yr
- Forced outage rate (FOR) [10]: 4%

### C. Generated Power of Renewable Units

The total produced power of renewable units can be calculated by means of summing the generated power of wind turbines and PV arrays. Therefore, the injected power of renewable units to DC bus can be calculated by the following

equation:

$$P_{ren} = N_{WG} \times P_{WG} + N_{PV} \times P_{PV} \quad (5)$$

where,  $N_{WG}$ , and  $N_{PV}$  are the total number of installed wind turbines and PV arrays, respectively.

To consider the outage probability of units (e.g. forced outages or scheduled outages), the following equation can be applied:

$$P_{ren} = (N_{WG} - n_{WG}^{fail}) \times P_{WG} + (N_{PV} - n_{PV}^{fail}) \times P_{PV} \quad (6)$$

where,  $n_{WG}^{fail}$ , and  $n_{PV}^{fail}$  are the number of wind turbines and PV arrays being out of the grid.

### D. Electrolyzer

The electrolyzer is responsible to electrolyze water into hydrogen and oxygen. In chemistry and manufacturing, electrolysis is a method of separating chemically bonded elements and compounds by passing an electric current through them. The electrolyzer consists of a number of cells isolated from one another in separate cell compartments. The generated power is stored in a tank.

The electrolyzer output power,  $P_{Ele-Tank}$ , can be calculated as follows:

$$P_{Ele-Tank} = P_{Ren-Ele} \times \eta_{Ele} \quad (7)$$

where,  $P_{Ren-Ele}$  is the delivered electric power to electrolyzer, and  $\eta_{Ele}$  is the electrolyzer efficiency. In this paper, the electrolyzer efficiency is considered to be constant during operation time. The rest of requiring data are as follows [9]:

- Investment cost: 2000 \$/unit
- Replacement cost: 1500 \$/unit
- Annual cost of maintenance and repair: 25 \$/unit.yr
- Lifetime: 20 yr
- Efficiency: 75%

### E. Hydrogen Tank

The stored energy in the hydrogen tank for each step-time can be calculated by the following equation:

$$E_{Tank}(t) = E_{Tank}(t-1) + P_{Ele-Tank}(t) \times \Delta t - P_{Tank-FC}(t) \times \Delta t \times \eta_{Storage} \quad (8)$$

where,  $\Delta t$  is the duration of each step-time which is equal to one hour, and  $\eta_{Storage}$  is the efficiency of storage system which is assumed 95% [11].

To calculate the mass of stored hydrogen in the tank, the following equation can be used:

$$m_{Storage}(t) = \frac{E_{Storage}(t)}{HHV_{H_2}} \quad (9)$$

such that,  $HHV_{H_2}$  is the higher heating value of hydrogen

which is equal to 39.7 kWh/kg [12]. The maximum mass of hydrogen, which can be stored in the tank, is equal to the rated capacity of the hydrogen tank. In addition, because of some technical problems (e.g. the pressure drop of hydrogen tank), the whole of hydrogen cannot be extracted. Therefore:

$$E_{Tank, \min} \leq E_{Tank}(t) \leq E_{Tank, \max} \quad (10)$$

The rest of requiring data for the hydrogen tank are as follows [9]:

Investment cost: 1300 \$/unit

Replacement cost: 1200 \$/unit

Annual cost of maintenance and repair: 15 \$/unit.yr

Lifetime: 20 yr

Efficiency [11]: 95%

Cost of purchasing hydrogen [11]: 18 \$/kg

#### F. Fuel Cell

A fuel cell is an electrochemical conversion device. It produces electricity from fuel (on the anode side) and an oxidant (on the cathode side), which react in the presence of an electrolyte.

The proton exchange membrane (PEM) fuel cells possess a reliable performance in the course of non-continuous operation conditions [13]. Additionally, they have a relative fast dynamic response. In this type of fuel cells, the output power can be calculated by the following equation:

$$P_{FC-Inv} = P_{Tank-FC} \times \eta_{FC} \quad (11)$$

where,  $P_{Tank-FC}$  is the delivered hydrogen power to fuel cell, and  $\eta_{FC}$  is the fuel cell efficiency. The rest of requiring data for the fuel cell are as follows [9]:

Investment cost: 3000 \$/unit

Replacement cost: 2500 \$/unit

Annual cost of maintenance and repair: 175 \$/unit.yr

Lifetime: 5 yr

Efficiency: 50%

#### G. DC/AC Converter

According to Fig. 1, a DC/AC converter has been employed to convert the DC generated power of HPP into the AC electricity power with desirable frequency. To consider the impact of converter loss on output power of HPP, the following equation can be used:

$$P_{Inv-Load} = (P_{FC-Inv} - P_{Ren-Inv}) \times \eta_{Inv} \quad (12)$$

where,  $\eta_{Inv}$  is the converter efficiency. The rest of requiring data for the converter are as follows [9]:

Investment cost: 800 \$/unit

Replacement cost: 750 \$/unit

Annual cost of maintenance and repair: 8 \$/unit.yr

Lifetime: 15 yr

Efficiency: 90%

Forced outage rate (FOR) [14]-[15]: 0.11%

### III. HYBRID SYSTEM RELIABILITY

It is vital to consider the real profits of applying wind and PV energy and the key variables that dictate or affect the economics involved. A realistic appraisal of the monetary profits associated with these energy sources also requires an evaluation of the system reliability level that can be obtained when using these sources. It is fairly evident that restrictions in the energy available from renewable energy sources and their intermittent performance degrade system reliability. Cost/benefit analysis associated with the application of wind and PV energy is incomplete without a corresponding reliability evaluation [10].

In this paper, the wind blow and the solar radiation data are for a northwest region of Iran. In addition, the load pattern of IEEE reliability test system with a 50 kW annual peak load is used [16]. The aforementioned test system is simulated for one year (with one hour step-time) considering reliability/cost evaluation. Also, the results are extended for a 20 years horizon with deterministic data sets.

To evaluate the system reliability level, the Equivalent Loss Factor Index (ELF) has been used from various types of reliability indices. The ELF index can be expressed by the following expression [17]:

$$ELF = \frac{1}{N} \sum_{t=1}^N \frac{Q(t)}{D(t)} \quad (13)$$

where,  $Q(t)$ , and  $D(t)$  are the total load loss and the total load demand at  $t^{th}$  step-time, respectively. Also,  $N$  is the total number of step-times. This is informative that the maximum permissible level of the ELF index in the developed counties is more or less 0.0001 [17].

In this paper, reliability evaluation of HPP is investigated by considering the outage probability of generation units (e.g. wind turbines, and PV arrays), and DC/AC converter.

Based upon aforementioned forced outage rates used for wind and PV units, the availability to them is equal to 96%. Therefore, the failure probability of  $n_{WG}^{fail}$  wind turbines from the total number of installed turbines  $N_{WG}$ , and  $n_{PV}^{fail}$  PV arrays from the total number of installed arrays  $N_{PV}$  can be expressed by a binomial distribution function as follows [18]:

$$f_{Ren} = \left[ \binom{N_{WG}}{n_{WG}^{fail}} \times A_{WG}^{N_{WG} - n_{WG}^{fail}} \times (1 - A_{WG})^{n_{WG}^{fail}} \right] \times \left[ \binom{N_{PV}}{n_{PV}^{fail}} \times A_{PV}^{N_{PV} - n_{PV}^{fail}} \times (1 - A_{PV})^{n_{PV}^{fail}} \right] \quad (14)$$

where,  $A_{WG}$ , and  $A_{PV}$  are the availability of each wind turbine and each PV array, respectively. It is clear that the failure probability of other parts of HPP is less than wind turbines and PV arrays.

Since the forced outage rate of DC/AC converter is 0.11%, its availability is equal to 99.89% [14]. Hence, the failure probability can be rewritten by the following equation:

$$f_{System} = f_{Ren} \times \left[ \left( \frac{N_{Inv}}{n_{Inv}^{fail}} \right) \times A_{Inv}^{N_{Inv} - n_{Inv}^{fail}} \times (1 - A_{Inv})^{n_{Inv}^{fail}} \right]. \quad (15)$$

where,  $n_{Inv}^{fail}$ ,  $N_{Inv}$ ,  $A_{Inv}$  are the number of failed converters, the total number of inverters, and the availability of each converter, respectively.

#### IV. OBJECTIVE FUNCTION DERIVATION

In essence, the general purpose of this paper is to demonstrate the optimal size of system components. The system costs can be divided into net present-value cost (NPC), maintenance and repair cost, replacement cost of devices, and the associated cost to load curtailment during 20 years horizon. The major constraint of problem is the maximum permissible level of the ELF index. Therefore, the net present value cost for a specific device can be expressed by the following equation [19]:

$$NPC_i = N_i \times \left( \frac{CC_i + RC_i \times K_i + MRC_i \times PWA(ir, R)}{MRC_i \times PWA(ir, R)} \right). \quad (16)$$

where:

$N$	Number of units and/or unit capacity (kW or Kg)
$CC$	Capital investment cost (\$/unit)
$RC$	Replacement cost (\$/unit)
$K$	Single payment present worth
$MRC$	Maintenance and repair cost (\$/unit-yr)
$PWA$	Annual payment present worth
$ir$	Real interest rate (6%)
$R$	Project lifetime (yr)

Also, the single payment present worth,  $K$ , the annual payment present worth,  $PWA$ , are defined by the following equations:

$$K_i = \sum_{n=1}^{y_i} \frac{1}{(1 + ir)^{n \times L_i}}. \quad (17)$$

$$PWA(ir, R) = \frac{(1 + ir)^R - 1}{ir(1 + ir)^R}. \quad (18)$$

where,  $y$ , and  $L$  are the total number of replacements and the lifetime of a specific device, respectively.

Based upon the definition of Loss of Energy Expectation index (LOEE), which is demonstrated in the appendix, the net present-value cost of load loss can be expressed by the following equation:

$$NPC_{Loss} = LOEE \times C_{Loss} \times PWA. \quad (19)$$

such that,  $C_{Loss}$  is the equivalent cost of load curtailment per

kWh (\$/kWh). Therefore, the objective function of optimization problem can be illustrated as follows:

$$J = \min_X \left\{ \sum_i NPC_i + NPC_{Loss} \right\}. \quad (20)$$

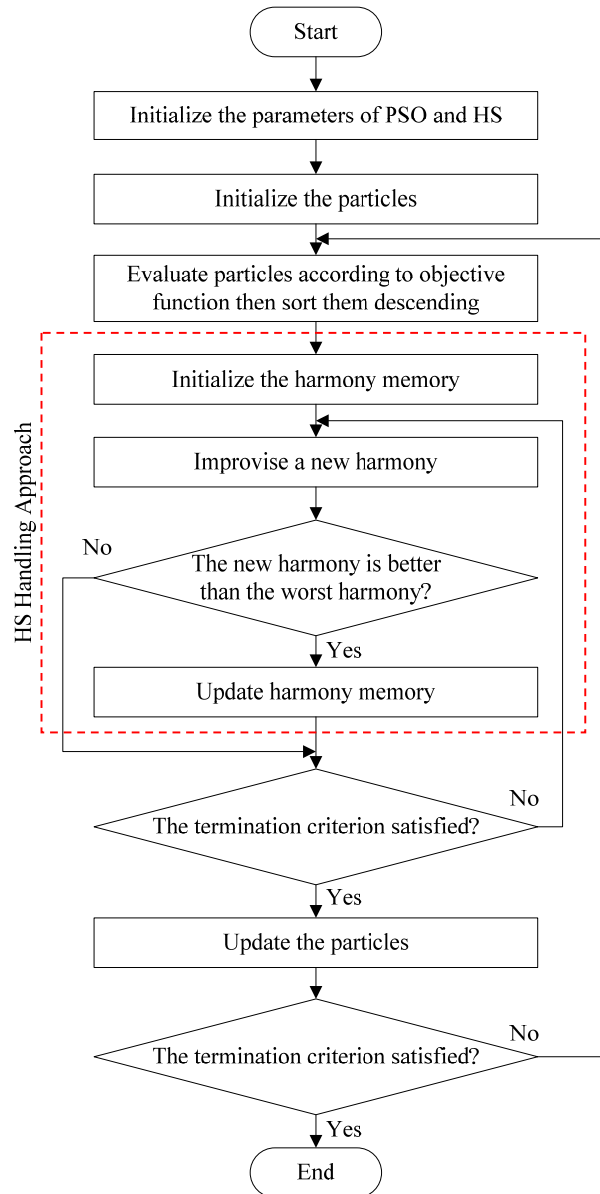

Fig. 3 The hybrid solution procedure

where,  $i$ , and  $X$  are the appropriate index of each device, and a 7-dimensional vector representing problem variables, respectively. The aforementioned objective function must be optimized with respect to the following constraints:

$$E[ELF] \leq ELF_{max}. \quad (21)$$

$$N_i \geq 0. \quad (22)$$

$$0 \leq \theta_{PV} \leq \frac{\pi}{2}. \quad (23)$$

$$E_{Tank}(0) \leq E_{Tank}(8760). \quad (24)$$

where,  $\theta_{PV}$  is the installation angle of each PV array. The final constraint represents the energy content of tank at the beginning of a year should not be less than its initial energy.

## V. HYBRID SOLUTION PROCEDURE

Over the last decades, a large number of algorithms have been developed to solve various optimization problems. The computational drawbacks of existing numerical methods have obligated researchers to trust in heuristic and meta-heuristic algorithms based upon simulations to solve optimization problems.

The major common factor in heuristic algorithms is to merge rules and arbitrariness to emulate natural phenomena. In this paper, a hybrid solution procedure consisting of PSO and HS is exploited to gain the optimal solution [20].

### A. Particle Swarm Optimization

The methodology of particle swarm optimization is an evolutionary algorithm introduced by Kennedy and Eberhart in 1995 [21]. The major motivation of PSO is social behavior of organisms such as fish schooling and bird flocking. Instead of applying evolutionary operators to manipulate the individuals, each individual in PSO flies in the search space with a velocity which is dynamically adjusted according to its own flying experience and its neighbors flying experience. Each particle denotes a candidate solution to a problem in an  $N$  dimensional space.

Consider an  $n$ -dimensional search space, and a population consisting of  $N$  particles. The  $i^{th}$  particle is an  $n$ -dimensional vector which can be expressed as follows:

$$X_i = (x_{i1}, x_{i2}, x_{i3}, \dots, x_{in})^T. \quad (25)$$

In addition, the corresponding velocity of this particle is also an  $n$ -dimensional vector represented by:

$$V_i = (v_{i1}, v_{i2}, v_{i3}, \dots, v_{in})^T. \quad (26)$$

Now, consider  $P_i$  to be the best previous position the  $i^{th}$  particle,  $P_g$  to be the particle that achieves the best previous position among all the individuals of the population, and  $t$  to be the iteration counter. Then, based upon the PSO definition, the population can be manipulated by the following expressions [22]-[23]:

$$V_i(t+1) = \omega(t) \times V_i(t) + c_1(t) \times r_1 \times (P_i(t) - X_i(t)) + c_2(t) \times r_2 \times (P_g(t) - X_i(t)). \quad (27)$$

$$X_i(t+1) = X_i(t) + \chi \times V_i(t+1). \quad (28)$$

where, the  $i = 1, 2, 3, \dots, N$  is the particle's index,  $\omega$  is the inertia weight,  $c_1$  and  $c_2$  express the cognitive and social parameters, respectively,  $\chi$  is the constriction factor,  $r_1, r_2$  are random numbers, uniformly distributed within the interval [0,1]. In essence, the inertia weight manipulates the impact of the previous record of velocities on the current velocity. An appropriate value for  $\omega$  provides the desired tradeoff between the global and local search capability of the population and, consequently, improves the effectiveness of the algorithm. The investigation results demonstrate an initial value of inertia weight close to 1 and a gradual decline toward 0 is considered a proper choice for  $\omega$ . In addition,  $c_1 = c_2 = 2$  is proposed as default values [22].

In this paper, the population size is chosen 10 times of problem variables number (i.e. 70 particles). Also, the total number of iterations is considered to be 150.

### B. Harmony Search

In essence, harmony search (HS) is a new meta-heuristic optimization technique emulating the music improvisation process where musicians improvise their instrument's pitches seeking for a perfect state of harmony [24].

Whereas musical instruments are played with certain discrete musical notes according to musician's experiences or arbitrariness in an improvisation process, design variables can be assigned with certain discrete values according to computational intelligence or arbitrariness in the optimization process. While musicians improve their experiences based on an artistic standard, design variables in computer memory can be enhanced based upon objective function.

Musical performances seek to find pleasing harmony as determined by an artistic standard, while the optimization process seeks to find a global solution as determined by an objective function.

In music improvisation, each player sounds any pitch within the possible range, together making one harmony vector. If all the pitches make a good harmony, that experience is stored in each player's memory, and the possibility to make a good harmony is increased next time. Likewise, in the engineering optimization, each decision variable initially chooses any value within the possible range, together making one solution vector. If all the values of decision variables make a good solution, that experience is stored in each variable's memory, and the possibility to make a good solution is also increased next time [25]-[27]. The methodology of HS can be demonstrated as follows:

First, consider an  $n$ -dimensional search space, and a specific number which determines the size of decision variables. The  $i^{th}$  design variable is an  $n$ -dimensional vector which can be limited between appropriate predefined boundaries as follows:

$$X_i = (x_{i1}, x_{i2}, x_{i3}, \dots, x_{in})^T \quad LX_i \leq X_i \leq UX_i. \quad (29)$$

Also, the HS algorithm parameters can be defined by the following terms:

- HMS* Harmony memory size or the number of solution vectors in the harmony memory
- HMCR* Harmony memory considering rate
- PAR* Pitch adjusting rate
- NI* Number of improvisations
- N* Number of decision variables

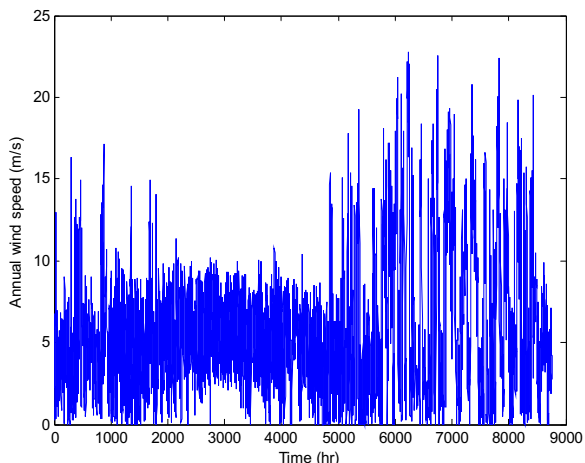

Fig. 4 Wind speed characteristic

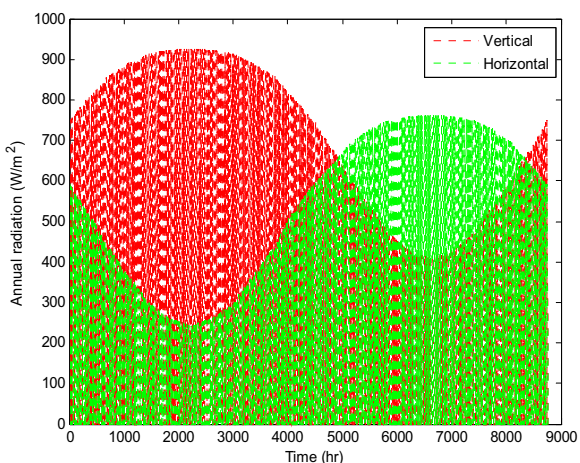

Fig. 5 Annual vertical and horizontal radiation

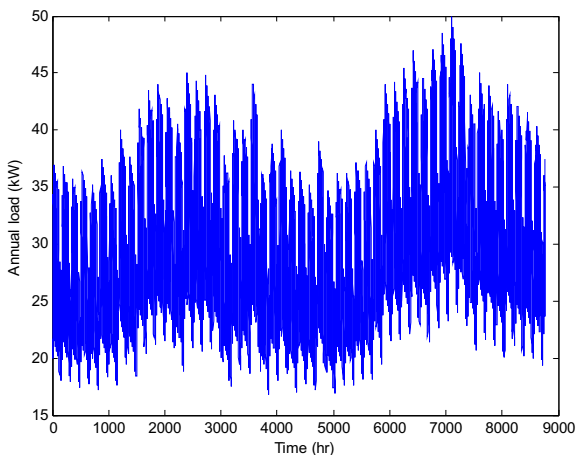

Fig. 6 Annual load pattern for IEEE RTS test system

Second, initialize the harmony memory. The HM is a memory location where all the solution vectors (sets of decision variables) are stored. The HM matrix is filled with as many randomly generated solution vectors as the HMS.

$$HM = \begin{bmatrix} x_1^1 & x_2^1 & \dots & x_{N-1}^1 & x_N^1 \\ x_1^2 & x_2^2 & \dots & x_{N-1}^2 & x_N^2 \\ \vdots & \vdots & \vdots & \vdots & \vdots \\ x_1^{HMS-1} & x_2^{HMS-1} & \dots & x_{N-1}^{HMS-1} & x_N^{HMS-1} \\ x_1^{HMS} & x_2^{HMS} & \dots & x_{N-1}^{HMS} & x_N^{HMS} \end{bmatrix} \quad (30)$$

Third, improvise a new harmony. A new harmony vector is generated based on three rules: memory consideration, pitch adjustment and random selection. Generating a new harmony is called *improvisation*. The value of the first decision variable ( $x'_1$ ) for the new vector can be taken from any value in the specified HM range. Values of the other design variables are chosen in the same manner.

The HMCR, which differs from 0 to 1, is the rate of choosing one value from the historical values stored in the HM, while 1-HMCR is the rate of randomly selecting one value from the possible range of values.

$$\left. \begin{array}{l} x'_i \in \{x_i^1, x_i^2, \dots, x_i^{HMS}\} \text{ with probability } HMCR \\ x'_i \in X_i \text{ with probability } (1 - HMCR) \end{array} \right\} \rightarrow x'_i \quad (31)$$

Each component of the new harmony vector is checked to reveal whether it should be pitch-adjusted. This operation exploits the PAR parameter. The rate of pitch adjustment can be expressed as follows:

$$\left. \begin{array}{l} \text{with probability } PAR \quad Yes \\ \text{with probability } (1 - PAR) \quad No \end{array} \right\} \rightarrow x'_i \quad (32)$$

This is informative that the value of 1-PAR states the rate of doing nothing. If the pitch adjustment decision for  $x'_i$  is yes,  $x'_i$  can be replaced by the following expression:

$$x'_i + bw \times U(-1,1) \rightarrow x'_i \quad (33)$$

where,  $bw$  is an arbitrary distance bandwidth for the continuous design variable, and  $U(-1,1)$  is a uniform distribution from  $-1$  to  $1$ . Therefore, HM consideration, pitch adjustment or random selection can be applied to each variable of the new harmony vector in sequence.

Forth, update harmony memory. If the new harmony vector is better than the worst harmony in the HM, from objective function perspective, the new harmony is included in the HM and the existing worst harmony is excluded from the HM.

Finally, if the stopping criterion (maximum number of improvisations) is fulfilled, computation is terminated. Otherwise, the manipulation process of the harmonic vector and the HM are repeated.

In this paper, the design variable is a 7-dimensional vector. The number of decision variables is taken to be 10 times of



TABLE I  
HYBRID POWER PLANT SPECIFICATIONS

Device	Investment Cost (\$/unit)	Replacement Cost (\$/unit)	Maintenance and Repair Cost (\$/unit-yr)	Lifetime (yr)	Efficiency (%)	Availability (%)
Wind Turbine	19400	15000	75	20	-	96
PV Array	7000	6000	20	20	-	96
Electrolyzer	2000	1500	25	20	75	100
Hydrogen Tank	1300	1200	15	20	95	100
Fuel Cell	3000	2500	175	5	50	100
DC/AC Converter	800	750	8	15	90	99.89

TABLE II  
TEST SYSTEM ASSUMPTIONS

System Lifetime	Real Interest Rate	$ELF_{max}$	Load Pattern	Peak Load	Load Curtailment Cost
20 Years	6%	0.01	IEEE RTS	50 kW	5.6 \$/kWh

TABLE III  
OPTIMAL SOLUTION OF HYBRID POWER PLANT

$N_{WG}$	$N_{WG}$	$P_{Ele}$	$M_{Tank}$	$P_{FC}$	$P_{Inv}$	$\theta_{PV}$
8	223	119.44	143.24	43.42	45.72	33.12

TABLE IV  
TEST SYSTEM COST EVALUATION

Investment Cost	$\sum_i NPC_i$	$NPC_{Loss}$
2.634 (M\$)	2.312 (M\$)	0.143 (M\$)

TABLE V  
TEST SYSTEM RELIABILITY EVALUATION

$ELF$	$LOLE$	$LOEE$	$LPSP$
2.67	335.85	2.34	0.00921

problem variables number (i.e. HMS = 70). Also, the HMCR, the PAR, and the maximum number of searches are considered to be 0.85, 0.35, and 150, respectively.

## VI. TEST SYSTEM SIMULATION

In this section, the aforementioned HPP is simulated by applying a hybrid PSO/HS approach outlined in Fig. 3. The annual wind blow and the annual solar radiation data are for a northwest region of Iran captured by one sample per hour precision.

The annual speed of wind at the 15 m height and the vertical/horizontal radiation curves are depicted in Fig. 4 and Fig 5, respectively. Fig. 6 illustrates the IEEE RTS load pattern with 50 kW annual peak load. Also, the cost of load curtailment is considered to be 5.6 \$/kWh [28]. The rest of requiring data are depicted in Table I and Table II.

A Pentium IV PC, CPU 2.8 GHz, 2 GB RAM, is applied for optimal allocation of HPP. The simulation time was around 15 hours. The acquired results are satisfactory in comparison with using only PSO algorithm because of the desirable property of HS which can save the suitable result of previous iterations in the harmony memory. Solution results are tabulated in Table III, Table IV, and Table V.

Based upon (20), the equivalent cost of load curtailment attaches an extra term to objective function. Also, (21) affects the level of load curtailment (i.e. loss of load), and limits its level. According to Table V, the obtained ELF index is less than its maximum value, which is expressed by (21).

Therefore, the system reliability constraint is not exceeded at the optimal point. In essence, the system reliability level enhancement is frugal in comparison with paying the cost of load curtailment.

## VII. CONCLUSION

Because of non-continuous characteristic of the annual wind blow and solar radiation, the challenging task is to plan a hybrid wind/PV plant which can supply the electricity demand in a reliable manner considering associated operation and investment costs.

In this paper, a methodology to optimal sizing of a hybrid wind/PV plant considering reliability indices is demonstrated. Also, a hybrid PSO/HS algorithm is applied to gain optimal solution. The major advantage of the hybrid solution procedure is its effectiveness to manipulate the new particles fulfilling the problem constrains.

## APPENDIX

### A. Reliability Indices

The reliability indices, which are applied in this paper, can be expressed by the following terms [16]-[28]-[29]:

- Loss of load expectation:
 
$$LOLE = \sum_i^N E [LOL(i)]. \quad (34)$$
- Loss of Energy Expectation:



$$LOEE = \sum_i^N E [LOE(t)]. \quad (35)$$

• Loss of Power Supply Probability:

$$LPSP = \frac{LOEE}{\sum_i^N D(t)}. \quad (35)$$

where,

$E [LOL(t)]$	Mathematical expectation of loss of load at step-time $t$
$E [LOE(t)]$	Mathematical expectation of loss of Energy at step-time $t$
$D(t)$	Load demand at step-time $t$ .

ACKNOWLEDGMENT

The first author is appreciative to the Green Research Center for the financial support.

REFERENCES

- [1] CIGRE technical brochure on modeling new forms of generation and storage, CIGRE, November 2000.
- [2] N. Acharya, P. Mahat, N. Mithulananthan, "An analytical approach for DG allocation in primary distribution network," *International Journal of Electrical Power and Energy Systems*, vol. 28, pp. 669–678, Dec. 2006.
- [3] *Impact of increasing contribution of dispersed generation on the power systems*, CIGRE, Working Group 37.23, 1999.
- [4] D. Robb, "Standing up to transmission reliability standards," *Power Engineering International*, vol. 12, pp. 20–22, Feb 2004.
- [5] Began, and R. Billinton, "Evaluation of different operation strategies in small stand-alone power systems," *IEEE Trans. Energy Conversion*, vol. 20, pp. 654–660, Sep. 2005.
- [6] J. Wilk, J. O. Gjerde, T. Gjengedal, M. Gustafsson, "Steady state power system issues when planning large wind farms," in *Proc. IEEE Power Engineering Society Winter Meeting*, 2002, vol. 1 pp. 199–204.
- [7] F. O. Hocaoglu, M. Kurban, "A preliminary detailed study on constructed hybrid (wind-photovoltaic) system under climatically conditions of eskisehir region in Turkey," in *Proc. IEEE International Power and Energy Conf.*, 2006, PECon'06, pp. 40–43.
- [8] M. H. Nehrir, B. J. Lameres, G. Venkataramanan, V. Gerez, L. A. Alvarado, "An approach to evaluate the general performance of stand-alone wind/photovoltaic generating systems," *IEEE Trans. on Energy Conversion*, vol. 15, no. 4, pp. 433–439, Dec 2000.
- [9] M. J. Khan, M. T. Iqbal, "Pre-feasibility study of stand-alone hybrid energy systems for applications in newfoundland," *Renewable Energy Journal*, vol. 30, issue. 6, pp. 835–854, May 2005.
- [10] R. Karki, R. Billinton, "Reliability/cost implications of PV and wind energy utilization in small isolated power systems," *IEEE Trans. on Energy Conversion*, vol. 16, issue 4, pp. 368–373, Dec. 2001.
- [11] M. Y. El-Sharkh, M. Tanrioven, A. Rahman, M. S. Alam, "Cost related sensitivity analysis for optimal operation of a grid-parallel PE fuel cell power plant," *Journal of Power Sources* 161, pp. 1198–1207, 2006.
- [12] K. Strunz, E. K. Brock, "Stochastic energy source access management: infrastructure-integrative modular plant for sustainable hydrogen electric cogeneration," *International Journal of Hydrogen Energy* 31, pp. 1129–1141, 2006.
- [13] T. F. El-Shatter, M. N. Eskander, M. T. El-Hagry, "Energy flow and management of a hybrid wind/PV/fuel cell generation system," *Energy Conversion and Management* 47, pp. 1264–1280, 2006.
- [14] M. Murchison, S. Savio, "Reliability analysis of a fuel cell electric city car," in *Proc. IEEE European Conference on Power Electronics and Applications*, pp. 11–14, Sep. 2005.
- [15] M. K. Khairil, S. Javanovic, "Reliability modeling of uninterruptible power supply systems using fault tree analysis method," *European Transaction on Electrical Power*, Jul. 2008.
- [16] R. Billinton, R. N. Allan, *Reliability Evaluation of Power Systems*. 2nd ed., New York: Plenum Press, 1996, ch. 2.
- [17] R. S. Garcia, D. Weisser, "A Wind-diesel system with hydrogen storage: joint Optimization of design and dispatch," *Renewable Energy Journal* vol. 31, issue 14, pp. 2296–2320, Nov. 2006.
- [18] R. Billinton, R. N. Allan, *Reliability Evaluation of Engineering Systems: Concepts and Techniques*. New York: Plenum Press, 1983, ch. 3.
- [19] S. M. Hakimi, S. M. Tafreshi, A. Kashefi, "Unit sizing of a stand-alone hybrid power system using particle swarm optimization (PSO)," in *Proc. International Conference on Automation and Logistics*, pp. 3107–3112, Aug. 2007.
- [20] L. G. Li, Z. B. Huang, F. Liu, and Q. H. Wu, "A heuristic particle swarm optimizer for pin connected structures," *Computers & Structures Journal*, vol. 85, issues 7–8, pp. 340–349, Apr. 2007.
- [21] R. C. Eberhart, J. Kennedy, "A new optimizer using particle swarm theory," in *Proc. 6th Symposium on Micro Machine and Human Science*, pp. 34–44, Oct. 1995.
- [22] K. E. Parasopoulos, M. N. Vrahatis, "On the computation of all global minimizers through particle swarm optimization," *IEEE Trans. on Evolutionary Computation*, vol. 8, issue 3, pp. 211–224, June 2004.
- [23] B. Jarboui, N. Damak, P. Siarry, A. Rebai, "A combinatorial particle swarm optimization for solving multi-mode resource-constrained project scheduling problems," *Applied Mathematics and Computation*, vol. 195, issue 1, pp. 299–308, Jun. 2008.
- [24] K. S. Lee, Z. W. Geem, "A new meta-heuristic algorithm for continuous engineering optimization: harmony search theory and practice," *Computer Methods in Applied Mechanics and Engineering*, vol. 194, issues 36–38, pp. 3902–3933, Sep. 2005.
- [25] Z. W. Geem, "Novel derivative of harmony search algorithm for discrete design variables environmental planning and management program," *Applied Mathematics and Computation*, vol. 199, issue 1, pp. 223–230, May 2008.
- [26] Z. W. Geem, J. H. Kim, G. V. Loganathan, "A new heuristic optimization algorithm: harmony search," *SAGE Journals, SIMULATION*, vol. 76, no. 2, pp. 60–68, 2001.
- [27] A. Kaveh, S. Talataheri, "Particle swarm optimizer, ant colony strategy and harmony search scheme hybridized for optimization of truss structures," *Computers & Structures Journal*, vol. 87, issues 5–6, pp. 267–283, Mar. 2009.
- [28] R. S. Garcia, D. Weisser, "A wind-diesel system with hydrogen storage: joint optimization of design and dispatch," *Renewable Energy Journal*, vol. 31, issue 14, pp. 2296–2320, Nov. 2006.
- [29] D. Xu, L. Kang, L. Chang, B. Cao, "Optimal sizing of standalone hybrid wind/PV power systems using genetic algorithms," in *Proc. Canadian Conference on Electrical and Computer Engineering*, pp. 1722–1725, May 2005.