

A Fixed Band Hysteresis Current Controller for Voltage Source AC Chopper

K. Derradji Belloum, and A. Moussi

Abstract—Most high-performance ac drives utilize a current controller. The controller switches a voltage source inverter (VSI) such that the motor current follows a set of reference current waveforms. Fixed-band hysteresis (FBH) current control has been widely used for the PWM inverter. We want to apply the same controller for the PWM AC chopper. The aims of the controller is to optimize the harmonic content at both input and output sides, while maintaining acceptable losses in the ac chopper and to control in wide range the fundamental output voltage. Fixed band controller has been simulated and analyzed for a single-phase AC chopper and are easily extended to three-phase systems. Simulation confirmed the advantages and the excellent performance of the modulation method applied for the AC chopper.

Keywords—AC chopper, Current controller, Distortion factor, Hysteresis, Input Power Factor, PWM.

I. INTRODUCTION

AC choppers or ac voltage regulators have been widely used to obtain a variable AC voltage from a fixed AC source. The phase angle control (PAC) of AC voltage regulators is extensively employed in many applications such as industrial heating, lighting control, and starting and speed control of induction motors. This technique offers the advantages of simplicity and ability of controlling large amount of power economically. However, a delayed firing angle causes a discontinuity and significant harmonics in load current, and a lagging power factor also occurs at the ac side even though the load is completely resistive [7].

These problems can be partially solved by using more advanced control such as symmetrical angle control (SAC) [2], asymmetrical angle control (AAC) [3],[4],[5], and time ratio control of high frequency (TRC), or by introducing a freewheeling path in the power circuit. In development of power semiconductor devices, PWM techniques are increasingly being encouraged and can be classified largely into two types: the first type may be called “programmed firing angle control”, which can be realized with the help of microprocessors such as symmetrical pulse width modulated (SPWM) [9],[10], asymmetrical pulse width modulated (APWM) [3],[4]. Selected harmonics can be eliminated, or total harmonic distortion can be minimized by off-line

calculation of the optimal firing angles. However, this “pre-decided” control is not effective in suppressing the load harmonics caused by nonlinear loads. The other type can be called the “time optimal response control” or “instantaneous feedback control” [11], which have the advantages in improving motor system dynamics in high performance AC drive system and in suppressing of load harmonics. The last type of controllers “on-line control” is widely used for a PWM inverter. This control principle is well described in [11], [12]. Thus the principal contribution of this paper is the development of the same technique in an ac chopper.

The AC chopper analyzed here has a feedback loop such that the switching mode is determined by comparison of the actual current and sinusoidal reference current, or the actual current oscillates in fixed band hysteresis (FBH). The error current is then applied to a hysteresis element, which give the PWM pattern. The output of the switching elements supplies an R-L load. The primary feature of this controller is its simplicity. Secondly, FBH control is designed such that theoretically only one fixed frequency component should exist in the output ripple current. Thirdly, since this controller has non-linear element and a feedback loop in itself, the controller ensures not only quick and precise response to the command, but also minimization of errors and fast recovery from disturbances and non-linearities which affect the system accuracy.

This paper describes the method FBHC used for an AC chopper. Through digital simulation (MATLAB “SIMULINK”), several characteristics such as changes of the harmonics of output current, the distortion factor, and the input power factor of the fundamental current are investigated. Finally, the simulations results with R-L load of the FBHC controller are presented to verify the theoretical results.

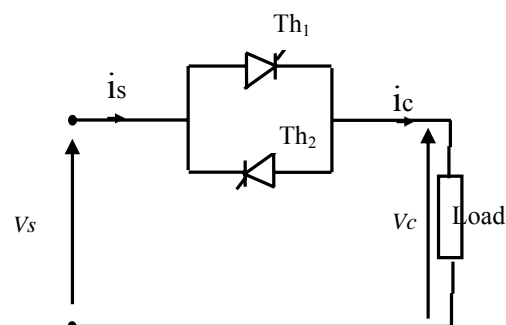

K. Derradji. Belloum is with Department of Electric Engineering, Biskra University, Algeria (e-mail:derradji_karima@hotmail.com).

A. Moussi is with Department of Electric Engineering, Biskra University, Algeria..

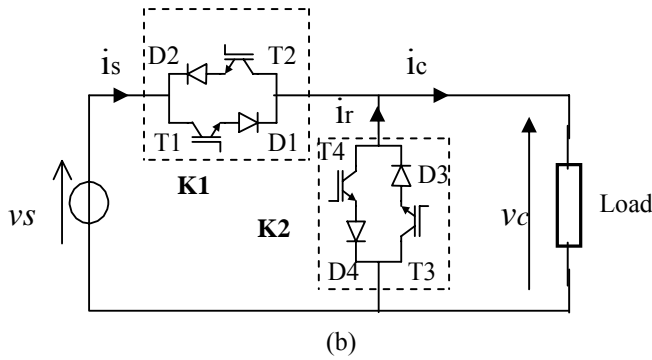

Fig. 3 Power circuit of an AC chopper
 (a) Phase control (b) Pulse width modulation References

II. POWER CIRCUIT

The power circuit of PWM AC chopper (Fig 1(b)) consists of two pairs of inverse-parallel connected solid-state switches (MOSFET transistors, IGBT...etc.); one connected in series (K_1), and the other in parallel (K_2) with the load. The solid-state switches are implemented using insulated gate bipolar transistors (IGBT). Each IGBT is connected in series with a diode to block the reverse voltage. The series connected K_1 regulate the power delivered to the load, and the parallel ones provide the freewheeling path to discharge the stored energy when the series ones are turned off. The output voltage may be controlled by changing the modulation index, $S_o = \text{ton} / (\text{ton} + \text{toff})$, of the series IGBTs T1 and T2. The chopper circuit shown in Fig. 1(b), with an R-L load, has four modes of operation. These modes are illustrated in Fig. 4. In mode I, which corresponds to positive supply voltage and positive load current, T1 is chopping, T4 is open, and T2 and T3 are closed. Mode II corresponds to positive supply voltage but negative load current. In this mode, the load feeds power back to the supply through T2. As shown in Fig. 4, the positive supply voltage is applied to the load. Hence, the chopping of T1 becomes redundant. During the negative half cycle, mode III and mode IV are similar to mode I and mode II, respectively. In mode III, T2 is chopping, T3 is open, and T1 and T4 are closed. In mode IV, the load feeds power back to the supply through T1.

During each half-cycle, the series IGBT are turned off for an extinction angle, β . The extinction angle is measured from the zero crossing point of the supply voltage toward the beginning of the half cycle. During this angle, the supply will deliver no current to the load. However, the load current may freewheel through the parallel IGBTs T3 and T4. This would eventually improve the input power factor. The output voltage may be controlled by changing S_o and /or β .

Figs. (2, 4) show the waveforms of the switching signals, the output voltages, and currents in the conventional PWM AC chopper. It is assumed that the load power factor F_{pc} is about $\cos\phi = 0.846$, and the pulses M per half cycle is 6. In the conventional PWM technique of Fig. 2, a switching signal is determined by the intersecting instants of the fixed triangular carrier wave and the constant switching function S_0 Fig. 2(a).

When the switching signal is applied to the power switches of an AC chopper, the symmetrical PWM output voltage appears at the load terminal Fig. 4(a) and the input and output current are obtained Fig. 4 (b)-(c) with corresponding spectrum Fig. 4 (a'')-(b'')-(c'').

This technique produces an approximately sinusoidal load current for inductive loads without filters. This eliminates the harmonics of the output voltage and current and input current up to the order $(2M-3)$ with dominant harmonics $(2M-1)$ and $(2M+1)$ Fig. 2(d)-(f)-(h) but is not effective in suppressing load harmonics caused by nonlinear loads.

Fig. 3 demonstrates the normalized value of the voltage v_c versus the duty cycle S_o . It is clear that the relation between the fundamental component of the output voltage and duty cycle is almost linear over most of the control range.

These PWM waveforms can be obtained by solving the Next differential equation, for the circuit of Fig. 1 (b) [4],[5]:

$$V_c(\theta) = \omega L \frac{di_c(\theta)}{d\theta} + Ri_c(\theta) \quad (1)$$

When a PWM switching pattern S is specified and the AC source V_s is given, the expression of the output becomes:

$V_c(\theta) = S(\theta) V_s(\theta)$. And if the base current I_B is defined as:

$$I_B = \sqrt{2} V_s / Z, \quad (Z = \sqrt{R^2 + (\omega L)^2}),$$

Equation (1) normalized as follows:

$$V_{CN}(\theta) = \sin(\phi) \frac{di_{CN}(\theta)}{d\theta} + \cos(\phi) i_{CN}(\theta) \quad (2)$$

Where,

$$V_{CN}(\theta) = V_c(\theta) / I_B \cdot Z \quad (3)$$

$$\text{And } I_{CN}(\theta) = I_c(\theta) / I_B \quad (4)$$

To find the normalized output current i_{CN} by digital computer, equation (2) should be changed into the difference equation. Also the expressions of the current in ac line and free-wheel path are gives as [4]:

$$i_{SN} = S(\theta) \cdot i_{CN}(\theta). \quad (5)$$

$$i_{RN}(\theta) = I_{CN}(\theta) - i_{SN}(\theta) \quad (6)$$

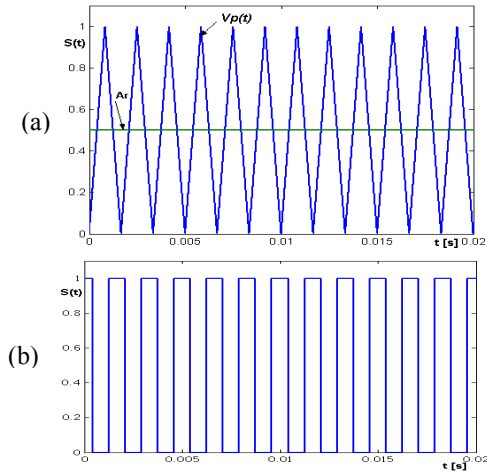

Fig. 2 The switching function

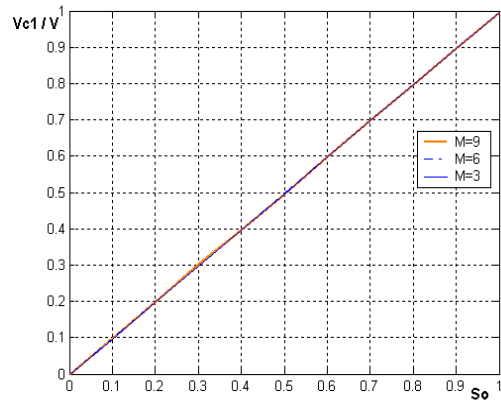

Fig. 3 Fundamental output voltage with variation of duty cycle for:
 $M=3,6,9$

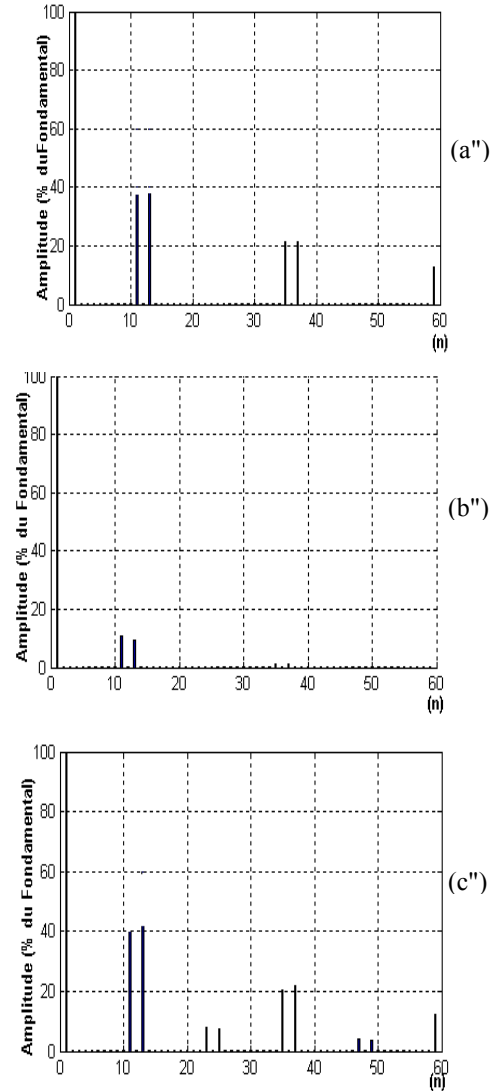
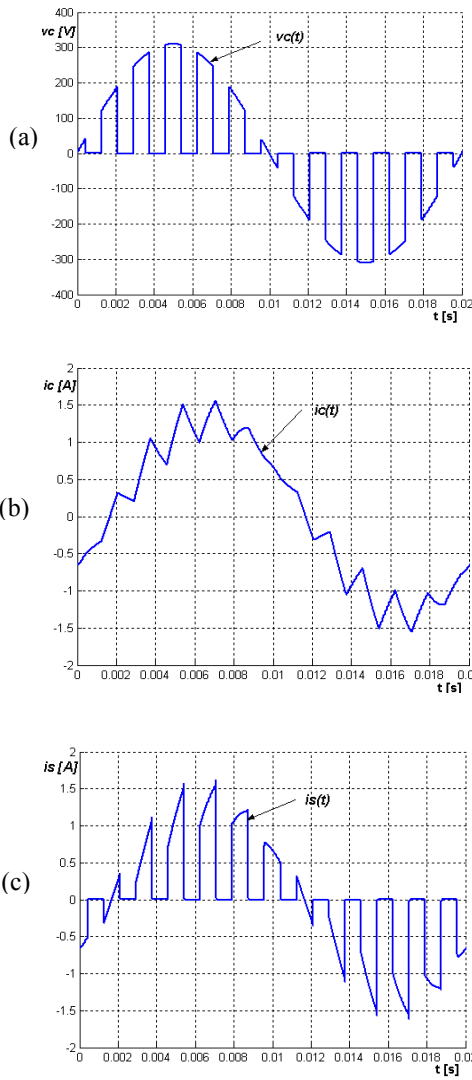

Fig. 4 Waveforms of, the output voltage and currents in PWM AC chopper $M=6$, $So=0,5$, $\text{Cos } \varphi = 0.846$

III. BASIC CONCEPTS OF INSTANTANEOUS FEEDBACK CONTROL

The basic structure of a single-phase current hysteresis control loop of a voltage source chopper (VSC) is shown in Fig. 5.

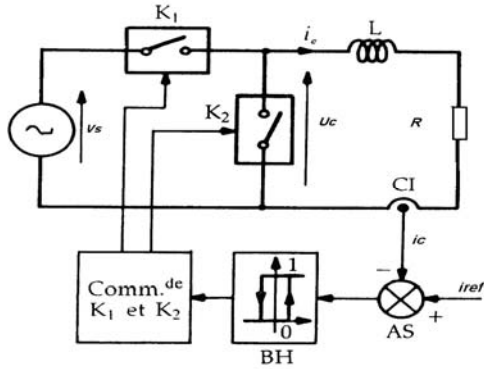

Fig. 5 Basic diagram of VSC Hysteresis Current Control (HCC)

The load current of the AC chopper is fed back to be compared with the reference current. In the hysteresis modulator (BH), the current error δ is compared with the hysteresis band, as shown in Fig. 5. When δ cross the upper boundary, the lower chopper switch K_2 is turned on and K_1 is turned off (here delays and dead times are neglected), while the opposite happens at the crossing of the lower boundary. As result the output voltage is transitioned from $V_s \cdot \sin \omega t$ to 0. The actual current is thus forced to track the sine reference wave within the desired hysteresis.

In this technique, the band of hysteresis is maintained constant during all the period of fundamental. The algorithm for this scheme is given as [1]:

$$i_{ref} = I_{max} \sin(\omega t)$$

$$\text{Upper band: } (i_u) \quad i_{ref} + \Delta i = i_{ref} + h/2$$

$$\text{Lower band: } (i_l) \quad i_{ref} - \Delta i = i_{ref} - h/2$$

Where: $2\Delta i = h$ is hysteresis band limit.

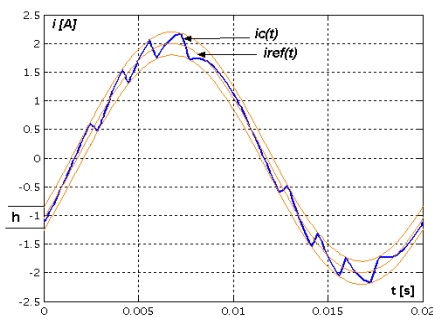

Fig. 6 Load current Waveform

The load voltage thus obtained is used to solve the differential equation (1) representing the R-L load. The load current waveforms are thus generated and simulation studies can be carried out.

- The total harmonic distortion factor of ac input current is defined as:

$$THD_{I_s} = \frac{1}{I_{s1}} \sqrt{I_s^2 - I_{s1}^2} = \sqrt{\left(\frac{I_s}{I_{s1}}\right)^2 - 1} \quad (7)$$

Where

I_s : rms. value of the supply current.

I_{s1} : rms. value of the fundamental current.

The THD value is a measure of the harmonic content of the current.

- The total harmonic distortion factor of the load current.

$$THD_{i_c} = \frac{\sqrt{I_c^2 - I_{c1}^2}}{I_{c1}} \quad (8)$$

- The input power factor

$$FP_h = \frac{I_{s1}}{I_s} \cos \phi_{s1}; \quad (9)$$

$$FD_{I_s} = \frac{I_{s1}}{I_s} \quad (10)$$

Where:

FD_{I_s} : input distortion factor

$\cos \phi_1$: fundamental input power factor

The power factor can be determined directly from the THD as follows:

$$FP_g = \frac{\cos \phi_1}{\sqrt{1 + THD_{I_s}^2}} \quad (11)$$

- The average chopper switching frequency (ASF) is defined as [1]:

$$ASF = \frac{N_c}{T} \quad (12)$$

Where N_c : number of switchings in one fundamental period,
 T : fundamental period,

- The maximum switching frequency (MSF) is defined as [1]:

$$MSF = 1/(T_1 + T_2) \quad (13)$$

Where:

T1: minimum time available for a switch to remain on from a previous off state,

T2: minimum time available for switch to remain off from a previous on state.

IV. SIMULATION RESULTS

A digital simulation (MATLAB “SIMULINK”) has been developed to study the performance of the fixed band controller for a single phase AC chopper. The harmonic spectra of several load current wave form is generated using fast Fourier transform (FFT). The parameters that govern the pattern of the control schemes are hysteresis bands (width), reference current and load impedance. The effect of varying the reference current for different band hysteresis has been discussed. The simulation has been performed for an R-L load with $R=100\Omega$ and $L=200mH$. a sine wave at 50HZ and 2A peak has been used as the reference. Simulation has been presented for the following cases:

- Case 1: $\Delta I = \pm 0.2 A$

Fig. 7 shows the steady-state current waveform and the corresponding harmonics distribution for $\pm 0.2A$ fixed-band current controller. The current is perfectly confined within the upper and the lower bands. Some of the higher order harmonics have a significant magnitude (Fig. 7(a)). The harmonics spectra contains some higher order harmonics Fig. 7(b). Also, the higher order harmonics have a lower magnitude.

- Case 2: $\Delta I = \pm 0.1 A$

Fig. 8 shows the current waveform and the corresponding harmonic spectra resulting from $\pm 0.1A$ fixed-band current controller. The spectrum contains some harmonics with a significant magnitude. Most of the harmonics with the ± 0.1 a fixed band spectra are suppressed (Fig. 8(b)).

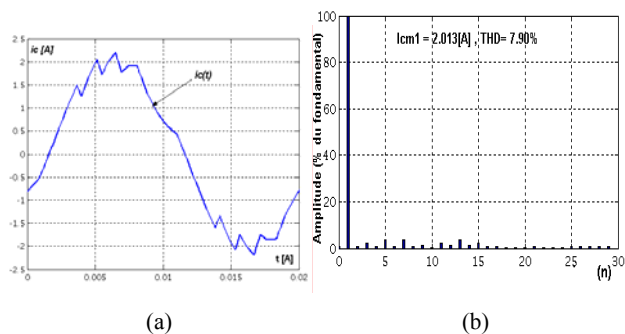

Fig. 7 (a) Current waveform (b) Harmonic spectrum $I_{ref}=2A$, $\Delta I=\pm 0.2A$

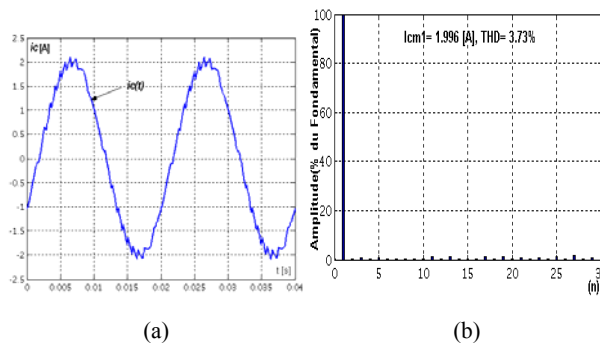

Fig. 8 (a) Current waveform (b) Harmonic spectrum $I_{ref}=2A$, $\Delta I=\pm 0.1A$

Output characteristics: To investigate the output characteristics of PWM AC chopper, the variation of RMS value of fundamental output current i_{c1} , load distortion factor and average switching frequency are found as seen in Fig. (9,10).

Control range: Fig. 9 represents the variation of RMS values of fundamental output current. The RMS values are regulated almost linearly to I_{ref} , and the changing shape can be considered to remain unchanged irrespective of hysteresis modulator for fixed band controller.

Average switching frequency [1]: Fig. 10 shows the variation of average switching frequency with hysteresis width.

Distortion factor [4], [5]: Fig. 11 illustrates the variation load distortion factor with the change of the hysteresis width for fixed hysteresis bands. The load distortion factor can reach the unity when the width decreases and becomes low when width increases as shown in Fig. 11.

Input characteristics: The ac input current has the discontinuities during the repetitive periods (5) even if load current becomes roughly sinusoidal. This causes the larger harmonics in the input side than those of load side (load current). Fig. (12,13) shows the changes of the distortion factor of the input current and the input power factor for fixed hysteresis band. The input distortion factor is less than the load distortion factor and is around 0,81. It means the harmonics generation in AC line current depends mainly upon the control variable, and not the load phase angle $\cos\phi$.

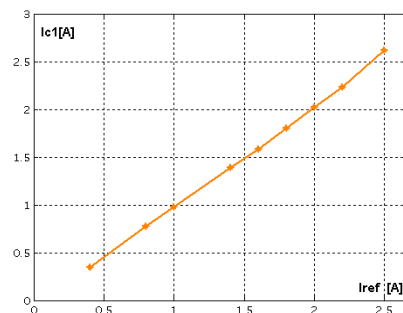

Fig. 9 The variation of RMS values of fundamental output current

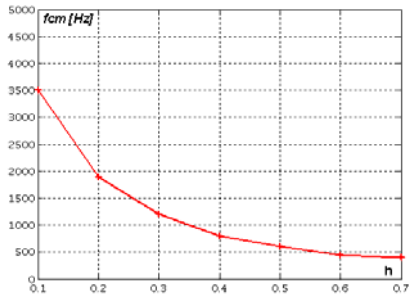

Fig. 10 Average switching frequency: Fundamental load current

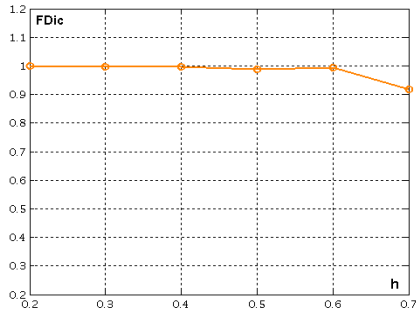

Fig. 11 The distortion factor of load current

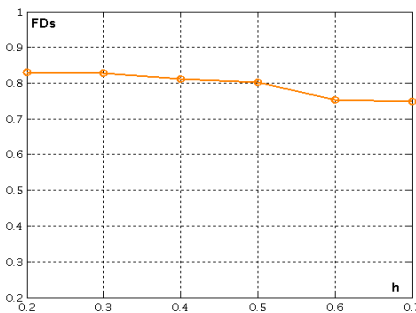

Fig. 12 The distortion factor of supply current

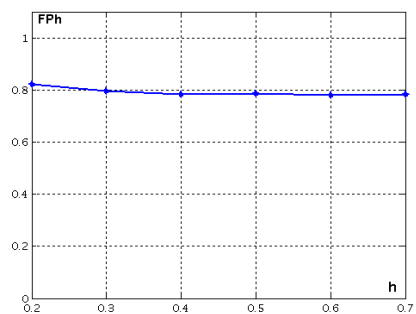
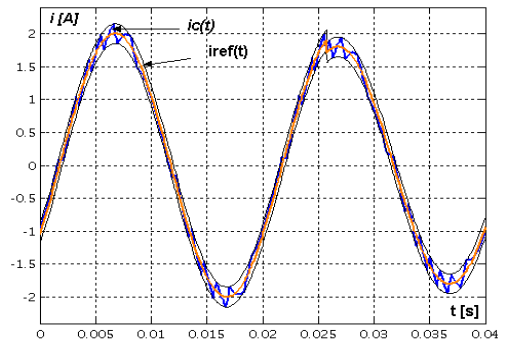

Fig. 13 The input power factor

With an aim of examining the robustness of the technique with respect to a sharp variation of the current of reference of the load, we will consider the following cases:

-Case 1: Brutal Reduction in the current of reference of Iref = 2A to Iref = 1.8A:



(a)

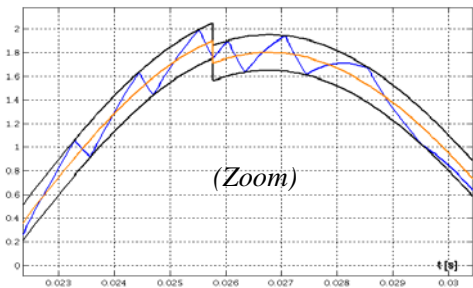

(b)

Fig. 14 (a) Load current with diminution in the current of reference at the time $t=0.0258s$, $h=0.3$. (b) Zoom

-Case 2: Brutal Increase in the current of reference of Iref. = 2A to Iref. = 2.2A:

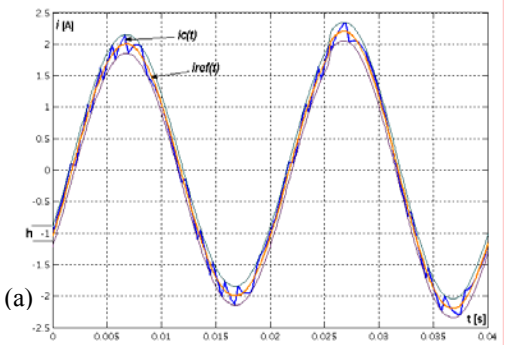

(a)

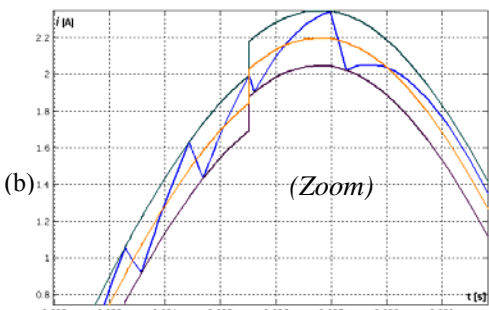

(b)

(Zoom)

Fig. 15 Load current with increase in the current of reference at the time $t=0.0255s$, $h=0.3$

Figs. 14 and 15 respectively show the shapes of waves of the load current in the event of an increase and a brutal reduction in the reference current. At the moment $t=0.0.255s$ the current of reference increases by 2 A with 2.2 A the current i_c catches up with its reference at the end of a short transitory mode, then follows it in a completely satisfactory way while remaining confined in the band of hysteresis.

V. CONCLUSION

This paper describes a PWM AC chopper controlled through fixed hysteresis band in an instantaneous feedback loop. The behavior of the fixed-band controller has been thoroughly studied. The principal characteristic of this method FBHC is the simplicity of implementation, and its robustness with respect to the disturbances and of the changes on the level of the parameters of the system.

The spectral analysis of the waveforms obtained by digital simulation shows that the harmonics of the tension and the load current are strongly attenuated in the case of this controller, which is explained by the improvement of the factor of distortion. Moreover, we conclude that the algorithm of the order is able to regulate the amplitude of the charging current with a factor of distortion around the unit.

The study shows that with a reasonable hysteresis width, this controller results in a reduced ripple and lower harmonic content. This should not be major concern with the availability of fast switching devices that low higher switching frequencies. The control strategy can easily be implemented in DSP based controllers and expand in three phase controllers.

REFERENCES

- [1] A. Tripathi, "Comparative analysis of fixed and sinusoidal band hysteresis current controllers for voltage source inverters", IEEE Trans on IE, vol.39, n°.1, February 1992, pp.63-73.
- [2] G.N.Revankar, "Symmetrical pulse width modulated Ac chopper," IEEE Trans. on Industrial .Electronics, vol.29, no.3, 1980, pp. 210-212.
- [3] B.W.Williams, "Asymmetrical Modulated AC chopper," IEEE Trans. on Industrial .Electronics, vol.29, no.3, 1982, pp.181-185.
- [4] D.Jang, G.Cho, and M.Ehsani, "Asymmetrical PWM Technique with Harmonic Elimination and Power Factor Control in AC choppers," IEEE Trans. on Power Electronics. vol.10, no.2, 1995, pp. 175-184.
- [5] Y.Hongxiang, L.Min, J.Yanchao, "An advanced Harmonic Elimination PWM Technique for AC choppers," IEEE Trans. on Power Electronics Specialists Conf., Vol.1, June 2004, pp.161-165.
- [6] A.Mozder, "Three-phase ac power control using power transistor," IEEE Trans. Industrial. Applicat., vol. 12, no.5,1976, pp. 499-505.
- [7] E.EL.Bidweihy, "Power factor of ac controllers for inductive loads," IEEE Trans.on Industrial .Electronics, vol.27, no.3,1980, pp. 210-212.
- [8] N.A.Ahmed, "A new configuration of single-phase symmetrical PWM AC chopper voltage controller," IEEE Trans. on Industrial .Electronics, Vol. 46, No 5, Oct.1999, pp. 942-952.
- [9] D-H.Jang, G-H.Cho, "Improvement of input power factor in AC choppers using asymmetrical PWM tech," IEEE Trans. on Industrial .Electronics, Vol.42, No2, April 1995, pp. 179 – 185.
- [10] K.E.Addowesh, "Microprocessor based harmonic elimination in chopper type ac voltage regulators," IEEE Trans. Power Electronics, vol.5, no.2, April 1990,pp.191-200.
- [11] A.Kwamura, "Instantaneous feedback controlled PWM inverter with adaptive hysteresis," IEEE Trans on Industrial. Applicat, vol.20, no.4, July/August, 1984.
- [12] C.Rossi, "Robust current controller for three inverter using finite-state automation", IEEE Trans on Industrial .Electronics, Vol.42, n°.2, April 1995, pp.169-178.
- [13] M.S.Khanniche, I.D.W.Lake, "Real time hysteresis controller for relay testing," IEE Proceedings on E.P.A, Vol. 141, no 2, March 1994, pp. 71-76.