

Introductory Design Optimisation of a Machine Tool using a Virtual Machine Concept

Johan Wall, Johan Fredin, Anders Jönsson and Göran Broman

Abstract—Designing modern machine tools is a complex task. A simulation tool to aid the design work, a virtual machine, has therefore been developed in earlier work. The virtual machine considers the interaction between the mechanics of the machine (including structural flexibility) and the control system. This paper exemplifies the usefulness of the virtual machine as a tool for product development. An optimisation study is conducted aiming at improving the existing design of a machine tool regarding weight and manufacturing accuracy at maintained manufacturing speed. The problem can be categorised as constrained multidisciplinary multi-objective multivariable optimisation. Parameters of the control and geometric quantities of the machine are used as design variables. This results in a mix of continuous and discrete variables and an optimisation approach using a genetic algorithm is therefore deployed. The accuracy objective is evaluated according to international standards. The complete systems model shows non-deterministic behaviour. A strategy to handle this based on statistical analysis is suggested. The weight of the main moving parts is reduced by more than 30 per cent and the manufacturing accuracy is improved by more than 60 per cent compared to the original design, with no reduction in manufacturing speed. It is also shown that interaction effects exist between the mechanics and the control, i.e. this improvement would most likely not been possible with a conventional sequential design approach within the same time, cost and general resource frame. This indicates the potential of the virtual machine concept for contributing to improved efficiency of both complex products and the development process for such products. Companies incorporating such advanced simulation tools in their product development could thus improve its own competitiveness as well as contribute to improved resource efficiency of society at large.

Keywords—Machine tools, Mechatronics, Non-deterministic, Optimisation, Product development, Virtual machine

I. INTRODUCTION

ON the increasingly competitive global market, users of machine tools demand increased accuracy and efficiency.

This forces machine tool developers to incorporate new methods and tools in their development processes. Virtual experimentation (advanced simulation tools) seems promising for addressing these new demands while at the same time attaining other benefits, such as shortened time-to-market. This has been shown in other areas of engineering; see, for

example, [1]. A virtual machine concept to support simulation-driven mechatronic design of CNC machine tools has therefore been developed in earlier work [2]. The virtual machine includes a real control system, simulation models of the machine having real-time capabilities as well as visualisation of the machine. The control system is a standard control system commonly used in the studied type of machine tools. This limits the design work to choosing suitable control system parameters. This parallel multidisciplinary design approach, simultaneously analyzing the mechanics and the control, and thereby utilising interaction effects, is believed to be superior to the traditional sequential design approach [3]. Other works related to the idea of a virtual machine are, for example [4], [5] and [6]. However, none of these incorporates detailed time-varying structural dynamics simulation capabilities.

The aim of this paper is to show the usefulness of the virtual machine concept for machine tool design optimisation. Designing a machine tool includes a wide variety of tasks ranging from selecting off-the-shelf products to designing unique parts from scratch. The design problem therefore usually consists of a mixture of continuous and discrete variables. Hence, a non-gradient based optimisation algorithm is well suited for the problem. Furthermore, in this type of problem many, often conflicting, objectives are usually present, i.e. it is a multi-objective problem. Methods able to handle this type of optimisation problem are discussed by, for example [7] and [8]. The complete multidisciplinary model of the studied mechatronic system shows a non-deterministic behaviour. Methods and strategies for non-deterministic simulations have in recent years received increased attention within the research community; see, for example [9] and [10]. The focus has been on systems with uncertain or variable model properties. However, in the virtual machine simulation, the source of non-determinism is inherent to the set-up. Statistical methods that consider this are suggested.

II. VIRTUAL MACHINE OVERVIEW

The virtual machine includes a real control system, a hardware-in-the-loop (HIL) simulation of the machine and a virtual reality model for visualisation of the machine, see Fig. 1.

J. Wall is with the Blekinge Institute of Technology, Karlskrona, SE 37179 Sweden (phone: +46 455385509; fax: +46 455385507; e-mail: johan.wall@bth.se).

J. Fredin is with the Blekinge Institute of Technology, Karlskrona, SE 37179 Sweden (phone: +46 455385524; fax: +46 455385507; e-mail: johan.fredin@bth.se).

A. Jönsson, is with the Blekinge Institute of Technology, Karlskrona, SE 37179 Sweden (phone: +46 455385582; fax: +46 455385507; e-mail: anders.jonsson@bth.se).

G. Broman, is with the Blekinge Institute of Technology, Karlskrona, SE 37179 Sweden (phone: +46 455385504; fax: +46 455385507; e-mail: goran.broman@bth.se).

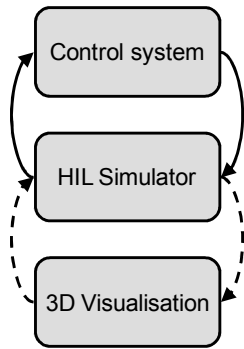

Fig. 1 Overview of the virtual machine

The HIL simulator contains a machine simulation model, hardware for reading actuator control signals as well as hardware for emulation of sensors, see Fig. 2.

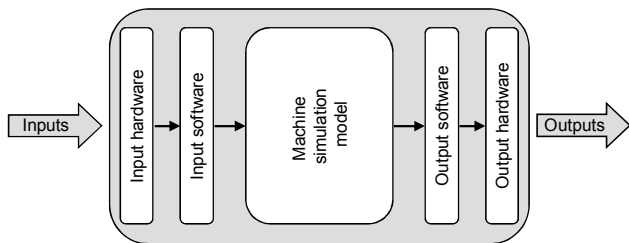

Fig. 2 HIL simulator

The machine simulation model is capable of describing the time-varying structural dynamic response of the studied machine in real-time. The need for real-time performance is because the inputs and outputs to and from the simulation have to be synchronised with a real control system. Therefore the cycle time of the simulation has to be the same as, or lower than, the cycle time of the control, in this work 250 μ s. For a detailed description of the virtual machine see [2].

III. CASE STUDY; DESIGN OPTIMISATION OF A WATER JET CUTTING MACHINE

This chapter describes the case study specifically while also giving general information about the chosen optimisation approach.

A. Water Jet Cutting Machine

Water jet cutting is a manufacturing technique that uses the erosion power of water to shape the work piece. The basic principle is to channel highly pressurised water (400 MPa or more) through a narrow nozzle in the cutting head, concentrating an extreme amount of energy in a small area and thereby creating massive cutting power. To further increase the cutting power abrasives are usually added to the process. More information about water jet cutting can be found in [11].

A schematic of the studied water jet cutting machine can be seen in Fig. 3. The machine has two axes of motion in the horizontal xy-plane.

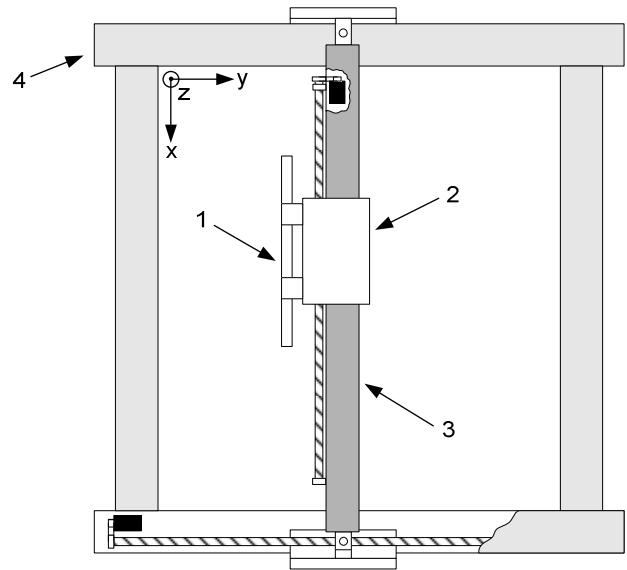

Fig. 3 Top view of the studied machine

A typical machine contains several cutting heads. In the studied machine design, the cutting heads are attached to the cutting head holder beam (1) which is mounted on the X-unit (2). The X-unit is able to move along the boom (3) enabling motion in the x-direction. The boom is able to move along the stand (4) enabling motion in the y-direction. Both axes are driven by electric motors via ball screws. A more thorough description of the machine design is given in [12].

B. Machine Simulation Model

The machine simulation model contains several sub-models; a structural dynamics model simulating the flexibility of the moving mechanical parts, a motor model and a multi-body model of the transmission. The complete model is built in Simulink (MATLAB) and controlled from MATLAB.

An ABAQUS finite element (FE) model constitutes the basis for the structural dynamics model. To achieve real-time capability the FE-models needs to be reduced in several steps by retaining only those modes that have a major influence on the dynamic response in the frequency range of interest and by only retaining the degrees of freedom of interest. The modal model is converted into state space model to enable implementation in Simulink. The development and validation of the FE-models are described in further detail in [12]. The reduction procedure as well as a further description of the simulation model of the transmission can be found in [2].

For the simulation model to be functional in an optimisation study it has to be parameterised and automated, i.e. the optimisation algorithm must be able to influence the model by varying certain aspects of it. While this is straight forward for the Simulink sub-models, tools enabling data exchange with ABAQUS is needed. This is realized through the software packages' ability to read and write ASCII-files.

The parameterisation of the FE-model is based on a sub-structuring approach. The unique parts of the machine are isolated as subsystems. Models for these subsystems are developed and validated. Some subsystem models are dynamic in the sense that they for arbitrary model parameters,

for example, geometric quantities or material properties, may be changed and re-built. Which subsystem models that are allowed to be dynamically changed and which are kept unchanged (static) depend on the choice of variables in the optimisation study. The subsystem models are then assembled into the complete FE-model of the machine in MATLAB. The model is sent to ABAQUS and solved. The results are imported back into MATLAB and used as a part of the machine simulation model.

The described simulation environment, combining ABAQUS with MATLAB, is very flexible, allowing automatic simulation and assessment of different machine configurations.

The complete machine simulation model is compiled into a real-time executable, and run on a real-time operating system, constituting the HIL-simulator described earlier.

1) Simulation Model Behaviour

Simulation results show a non-deterministic model behaviour, which is most likely due to the HIL-setup. Typical results of manufacturing accuracy from one typical machine configuration can be seen in Fig. 4 for 1000 simulation runs.

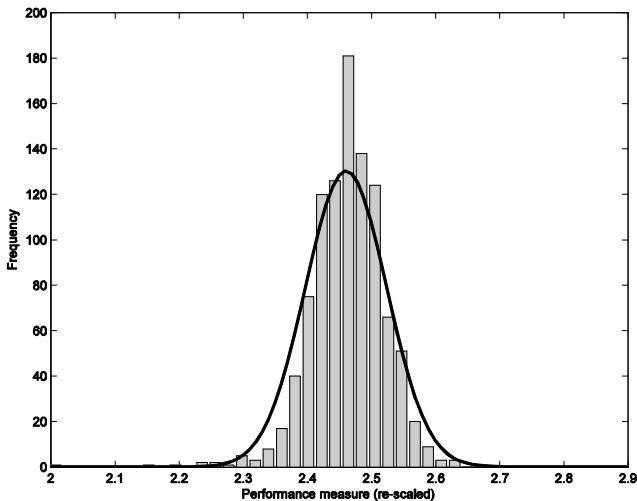

Fig. 4 Histogram showing variance of typical simulation results

The solid line is an estimated probability density function, assuming a Gaussian distribution, with the sample mean and sample standard deviation. Based on this, Gaussian distributed simulation results are assumed. The performance measure presented in Fig. 4 is re-scaled on request of the industrial partner. It is unit-less and does not explicitly represent the performance of the actual machine.

The variation must, of course, be considered when assessing machine tool performance. To get stable results, sufficiently many simulation runs with a given machine configuration must be carried out. To ensure this, the confidence interval of the predicted mean value is calculated. If the calculated interval is larger than a given threshold level (related to the expected magnitude of studied manufacturing accuracy) for a certain confidence level (99%), additional simulations are performed until the mean value is predicted with acceptable certainty. The confidence interval is calculated according to equation 1 [13]:

$$\bar{X} \pm t_{n-1} \left(\frac{\alpha}{2} \right) \frac{s}{\sqrt{n}} \quad (1)$$

where \bar{X} is the sample mean, t_{n-1} is Student's t distribution with $n-1$ degrees of freedom, $1-\alpha$ is the probability that the true mean value, μ , is contained within the calculated interval, s is the sample standard deviation, and n is the sample size.

From a robust design point of view, the variance of the performance measure used must also be considered in the optimisation study.

C. Optimisation Problem

The problem can be categorised as constrained multidisciplinary multi-objective multivariable optimisation with a mix of discrete and continuous variables. The problem is multidisciplinary since the simulation model is connected to a real control system.

1) Objectives

Obvious performance related objectives are accuracy, manufacturing speed and repeatability. Also of interest is the stroke of the x -axis, implying a trade-off between how large work pieces that can be machined in one set-up and the ability to cut several work pieces at the same time. A light weight design is also desirable, not the least from a general societal resource efficiency point of view. Three objectives are pursued in this introductory study: the weight of the main moving parts (which should also benefit energy and cost efficiency), the manufacturing accuracy and the manufacturing speed (i.e. the time it takes to cut the work piece). Since the feed rate is not a design variable in this study, the goal as regards the manufacturing speed is only to not have it significantly reduced.

The weight of the system is calculated by the finite element software. The manufacturing speed is easily obtained since the simulations are performed in real-time. The manufacturing accuracy is assessed according to the International Standard 230-4 [14]. A circular test is performed and the radial deviation is calculated. A fictitious test case is shown in Fig. 5.

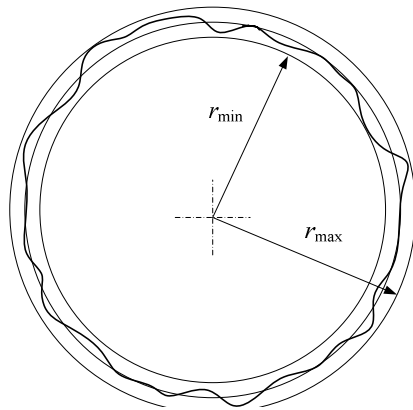

Fig. 5 Test case

The dash-dot line is the nominal path of radius r_{nom} that the machine tool is programmed to follow. The solid line represents the actual path produced by the machine tool (simulated motion of the tool centre point) when trying to follow the nominal path. The dashed lines are minimum and maximum concentric circles of radius r_{min} and r_{max} , respectively, enveloping the actual path. r_{max} and r_{min} are compared to r_{nom} and these deviations are used as a measure of the manufacturing accuracy (F_{tot}) according to equation 2.

$$F_{tot} = |r_{max} - r_{nom}| + |r_{nom} - r_{min}| \quad (2)$$

In this study the radius of the nominal path is 5 mm and the feed rate is 5000 mm per minute. This feed rate is higher than feed rates normally used in the industry today. The purpose of this is to provoke larger differences between machine configurations.

2) Variables

The virtual machine, including the machine model as well as the control, contains thousands of parameters. It is of course not practically possible to vary all of them in an optimisation study. Some key parameters in the machine and the control are chosen as variables. This selection was guided by experience among the industrial partners as well as from previous simulations.

The following parameters in the machine model are considered as variables in the current study: the cross section of the cutting head holder beam, the cross section (box type) and length of the boom and finally the width of the X-unit. These are parameters that are easily changed in practice. Some of them vary within the industrial partners' current product range.

The controller used is a closed-loop servo system. It includes a position loop as well as a velocity loop. The position loop gain is chosen as a variable in the study. The loop gain determines how hard the servo tries to reduce possible errors. As the loop gain increases, the response is improved. A too large loop gain, however, might make the servo system unstable. The time constant used for acceleration/deceleration of the cutting feed is also used as a variable. A low time constant gives a higher manufacturing speed while also inducing more vibrations in the system.

The chosen variables with allowed values for the discrete ones and bounds for the continuous ones are given in Table I. Variable values for the original design is given in bold. The number of possible combinations of the variables presented in

TABLE I
DESIGN VARIABLES

Variable description	Type	Values (original values in bold)
Cross section of cutting head holder beam	Discrete	40x80 light version, 40x80 , 80x80 (mm)
Width boom cross section	Discrete	0.125, 0.150 , 0.175 (m)
Height boom cross section	Discrete	0.225, 0.250 , 0.275 (m)
Thickness of material in boom cross section	Discrete	0.005, 0.010 , 0.015 (m)
X-unit width	Continuous	Bounds: 0.55 - 1.0 (m) (0.8)
Length of boom	Continuous	Bounds: 3.875 - 4.325 (m) (4.125)
Time constant used for acceleration/deceleration of cutting feed (#1622)	Discrete	50, 75, 100, 125, 150 , 175, 200, 225, 250 (ms)
Loop gain for position control (#1825)	Discrete	1000, 1750, 2500, 3250, 4000, 4750, 5500, 6250 , 7000 (0.01 s ⁻¹)
Cross section of cutting head holder beam	Discrete	40x80 light version, 40x80 , 80x80 (mm)
Width boom cross section	Discrete	0.125, 0.150 , 0.175 (m)
Height boom cross section	Discrete	0.225, 0.250 , 0.275 (m)
Thickness of material in boom cross section	Discrete	0.005, 0.010 , 0.015 (m)
X-unit width	Continuous	Bounds: 0.55 - 1.0 (m) (0.8)
Length of boom	Continuous	Bounds: 3.875 - 4.325 (m) (4.125)
Time constant used for acceleration/deceleration of cutting feed (#1622)	Discrete	50, 75, 100, 125, 150 , 175, 200, 225, 250 (ms)

table I depends on how the continuous variables are encoded (see chapter 3.4). With the "resolution" used, over 6 700 000 combinations are possible. Thus, the problem is well suited for numerical optimisation.

3) Constraints

There are restrictions on how values for the design variables may be assigned. In the current study the following constraints are applied: A minimum axis stroke is given as well as domain constraints (lower and upper bounds for chosen design variables). The calculation of the axis stroke is approximated as boom length minus X-unit length. A minimum value of 3.325 meters is given. The domain constraints are enforced automatically by the optimisation algorithm.

D. Optimisation Algorithm

A genetic algorithm (GA) is chosen since such have the ability to solve problems including both discrete and continuous variables. An in-house developed GA code is implemented in MATLAB. Real coded chromosomes are

used for the discrete variables and binary coding is used for the continuous ones. Reproductive operators are single-point crossover, mutation and elitism. Duplicate chromosomes are not allowed in the population. Parents are chosen by proportionate selection, i.e. based on their fitness relative to all other individuals in the population. GA's in general are described in detail in for example [15].

While the purpose of the current work is to show the potential of the virtual machine concept and not necessarily to develop a perfect machine tool, a simple strategy to handle the multiobjective aspect of the problem is adopted. The different objectives are aggregated to one single figure of merit by a weighted sum approach. Weights are assigned to each objective by the decision maker. The sum of all objectives adjusted by their respective weight factor is used as the figure of merit according to equation 3 [7].

$$f_w(\mathbf{x}) = \sum_{i=1}^m \left[\frac{f_i(\mathbf{x})}{f_{i0}} \right]^{\gamma_i} \quad (3)$$

where f_w is the aggregated figure of merit, m is the number of objectives, γ_i is the weight factor, f_i the i :th objective function, f_{i0} the i :th objective function value for the best known solution so far and \mathbf{x} the variable set.

The constrained problem is converted into an unconstrained problem through penalization of infeasible solutions. If a constraint is violated, a penalization term is added to the objective function. Penalizing a solution, still keeping it in the population, adds diversity compared to just removing the chromosome in question. This helps the GA avoid premature termination. A thorough discussion about constraint handling in GA can be found in [16].

E. Simulation Scheme

A worst case function call may take up to seven minutes to complete. This includes that a new FE-model needs to be built and solved, variable values changed that forces a re-start of the control system and that many samples are needed to get a stable mean. An efficient simulation scheme is therefore necessary. This is achieved by carefully planning the order in which the individuals in each generation are simulated. This might be seen as an optimisation problem in itself. Here, however, a simple rescheduling is applied where the individuals are sorted in groups related to the variable that is most time consuming to change. Within these groups the individuals are sorted once again in respect to the variable that is the next most time consuming to change. This procedure is continued until the generation is sorted for all variables. When a variable combination is simulated the results are saved in a data base. If this variable combination appears again in a subsequent generation the results are loaded from the data base avoiding time consuming simulation of known data. The same is true for the FE-model, once a model is built it is saved in a data base and re-used if needed.

IV. RESULTS

The optimisation algorithm converged to a design containing the following variable setting. Cross section 3 is

selected for the cutting head holder beam. This cross section is stiffer than the original one. The X-unit becomes 0.61 meters long. Hence it is close to its lower bound (0.55 meters). A cross section of 175x250x5 (mm) is selected for the boom and it is given a length of 3.99 meters. This significantly lighter boom combined with the chosen X-unit results in an axis stroke of more than 3.325 meters, i.e. satisfying the minimum stroke constraint. The time constant (control variable # 1622) is set to 100 (reduced by 33 %) and the loop gain (control variable # 1825) is unchanged and remains at 6250.

The normalised aggregated objective function shows a decrease from 1 to 0.60 which is a considerable improvement. The improvements of the individual objective functions are shown in Table II.

A typical simulation of the test case used comparing the improved machine design to the original one can be seen in Fig. 6. The dash-dot line is the nominal path (normalised) that the machine tool is programmed to follow. The solid and dotted lines represents the actual path produced using the improved and the original design, respectively.

TABLE II
OPTIMISATION RESULTS

Objective	Relative improvement compared to original design [%]
Weight of the system	31
Manufacturing accuracy	64
Manufacturing Speed	2.0

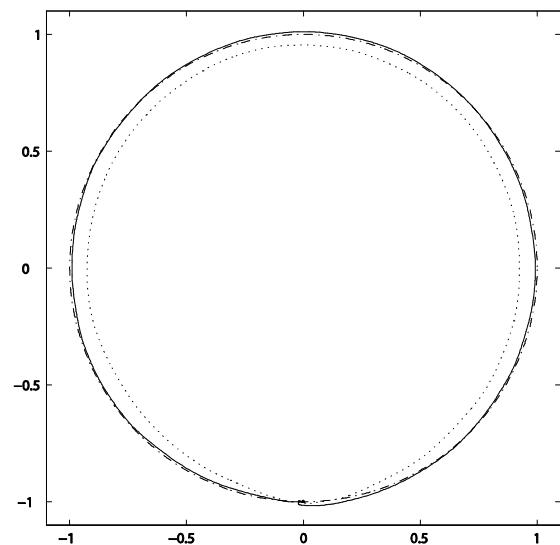

Fig. 6 Typical simulation results

One could argue that the large difference may to some extent be explained by a misfit of the original control parameters and the chosen test case. However, a design combining the original mechanics with the optimised control parameters is 52 per cent more accurate than the original design, i.e. it is still less accurate than optimised design (see Table II, 64 per cent improvement). It is also interesting to note that the opposite combination, i.e. a design combining the optimised mechanics with the original control parameters, is 4 per cent less accurate than the original design. These

comparisons indicate that interaction effects between the mechanics and the control exist. This is also illustrated by carrying out a sequential optimisation. That is, first optimising the mechanics using the original control (not varying any control parameters) and then optimising the control using optimal mechanics obtained from the first step. This sequentially optimised design is 44 per cent more accurate than the original design, i.e. far less accurate than the design obtained from the simultaneous optimisation.

V. DISCUSSION AND CONCLUSION

A virtual machine is used in an introductory design optimisation study to improve an existing water jet cutting machine design. The weight of the main moving parts of the machine, the manufacturing accuracy and the manufacturing speed at a specified feed rate are used as objective functions. A genetic algorithm is used because of the discrete nature of some of the chosen design variables, and this method performs well in the presented test case.

In-house developed tools for data exchange between ABAQUS and MATLAB enable parameterisation of the simulation model, which yields a flexible simulation environment that works very well in the presented test case. Furthermore a strategy to handle non-deterministic simulation results based on statistical methods for Gaussian distributed data shows good performance in the presented test case.

Already in this limited introductory study a significant potential for design improvements is revealed. The weight of the main moving parts is reduced by more than 30 per cent, the manufacturing accuracy is improved by more than 60 per cent and the manufacturing speed is increased by 2 per cent (i.e. at least maintained as desired).

It is also shown that interaction effects exist between the mechanics and the control, i.e. this improvement would most likely not been possible with a conventional sequential design approach within the same time, cost and general resource frame. This indicates the potential of the virtual machine concept for contributing to improved efficiency of both complex products and the development process for such products. Companies incorporating such advanced simulation tools in their product development could thus improve its own competitiveness as well as contribute to improved resource efficiency of society at large.

The positive results already from this introductory study encourage further work with the virtual machine concept. The HIL simulator as well as the optimisation algorithm will be refined in preparation of more comprehensive optimisation studies, in parallel with physical testing and redesign of real machine tools.

ACKNOWLEDGMENT

Financial support from the Knowledge Foundation and Region Blekinge in Sweden as well as from the Faculty Board of Blekinge Institute of Technology is gratefully acknowledged. We are also indebted to Water Jet Sweden AB, Ronneby, Sweden, and GE Fanuc Automation CNC Nordic AB, Stockholm, Sweden for invaluable support.

REFERENCES

- [1] Thomke S.H., *Experimentation matters: unlocking the potential of new technologies for innovation.*; Harvard Business School Press, Boston, 2003.
- [2] Jönsson A., Wall J. & Broman G., "A virtual machine concept for real-time simulation of machine tool dynamics", *International Journal of Machine Tools & Manufacture* 45(7-8), 2005, pp.795-801.
- [3] Van Brussel H., Sas P., Németh I., De Fonseca P. & Van den Braembussche P., "Towards a mechatronic compiler". *IEEE/ASME Transactions on Mechatronics* 6(1), 2001, pp. 90-105.
- [4] Dierssen S., "Systemkopplung zur komponentenorientierten Simulation digitaler Produkte", *VDI-Fortschrittberichte*, 20(358), VDI-Verlag GmbH, Düsseldorf, 2002.
- [5] Kreuzsch K., *Verifikation numerischer Steuerungen an virtuellen Werkzeugmaschinen, Berichte aus der Steuerungs- und Regelungstechnik*, Shaker Verlag, Aachen, 2002.
- [6] Altintas Y., Brecher C., Weck M. & Witt S., "Virtual machine tool", *Annals of CIRP* 54(2), 2005, pp. 651-674.
- [7] Andersson J., "A survey of multiobjective optimization in engineering design", Technical report LiTH-IKP-R-1097, Department of Mechanical Engineering, Linköping University, Linköping, 2000.
- [8] Ehrgott M. & Gandibleux X., "A survey and annotated bibliography of multiobjective combinatorial optimization", *OR Spektrum* 22(4), 2000, pp. 425-460.
- [9] Schuëller G.L., "Computational stochastic mechanics – recent advances", *Computers and Structures* 79(22-25), 2001, pp. 2225-2234.
- [10] Moens D. & Vandepitte D., "A survey of non-probabilistic uncertainty treatment in finite element analysis", *Computer Methods in Applied Mechanics and Engineering* 194(12-16), 2005, pp.1527-1555.
- [11] Summers D.A., *Waterjetting technology*, Spon Press, London, 1995.
- [12] Wall J., Englund T. & Berghuvud A., "Identification and modelling of structural dynamics characteristics of a water jet cutting machine", in: *Proceedings of the International Modal Analysis Conference - IMAC*, Dearborn, 26-29 January, 2004, pp. 138-147.
- [13] Rosenkrantz W.A., *Introduction to probability and statistics for scientists and engineers*, McGraw-Hill, New York, 1997.
- [14] ISO 230-4:2005, "Test code for machine tools – Part 4: Circular tests for numerically controlled machine tools".
- [15] Gen M. & Cheng R., *Genetic algorithms & engineering optimization*, John Wiley & Sons, New York, 2000.
- [16] Coello Coello C.A., "Theoretical and numerical constraint-handling techniques used with evolutionary algorithms: a survey of the state of the art". *Computer Methods in Applied Mechanics and Engineering* 191(11-12), 2002, pp. 1245-1287.