

RF Permeability Test in SOC Structure for Establishing USN(Ubiquitous Sensor Network)

Byung – wan Jo, Jung – hoon Park, Jang - wook Kim

Abstract—Recently, as information industry and mobile communication technology are developing, this study is conducted on the new concept of intelligent structures and maintenance techniques that applied wireless sensor network, USN (Ubiquitous Sensor Network), to social infrastructures such as civil and architectural structures on the basis of the concept of Ubiquitous Computing that invisibly provides human life with computing, along with mutually cooperating, compromising and connecting networks each other by having computers within all objects around us.

Therefore, the purpose of this study is to investigate the capability of wireless communication of sensor node embedded in reinforced concrete structure with a basic experiment on an electric wave permeability of sensor node by fabricating molding with variables of concrete thickness and steel bars that are mostly used in constructing structures to determine the feasibility of application to constructing structures with USN.

At this time, with putting the pitches of steel bars, the thickness of concrete placed, and the intensity of RF signal of a transmitter-receiver as variables and when wireless communication module was installed inside, the possible communication distance of plain concrete and the possible communication distance by the pitches of steel bars was measured in the horizontal and vertical direction respectively. Besides, for the precise measurement of diminution of an electric wave, the magnitude of an electric wave in the range of used frequencies was measured by using Spectrum Analyzer. The phenomenon of diminution of an electric wave was numerically analyzed and the effect of the length of wavelength of frequencies was analyzed by the properties of a frequency band area.

As a result of studying the feasibility of an application to constructing structures with wireless sensor, in case of plain concrete, it shows 45cm for the depth of permeability and in case of reinforced concrete with the pitches of 5cm, it shows 37cm and 45cm for the pitches of 15cm.

Keywords— Ubiquitous, Concrete, Permeability, Wireless, Sensor

I. INTRODUCTION

Structural health monitoring and damage detection have been of great concerns in the design, operation, maintenance, and repair of many civil structures. In order to monitor the health of large infrastructures such as bridges, highways, buildings, and dams, the outputs from various kinds

Byung-wan Jo is Professor, Dept. of Civil engineering, Hanyang university, Seoul, South Korea (phone: +82-2-2220-0327; fax: +82-2-2292-0321; e-mail: goolss@nate.com).

Jung-hoon Park is a candidate for the PhD, of civil engineering, Hanyang University, Seoul, South Korea (phone: +82-2-2220-0327; fax: +82-2-2292-0321; e-mail: ykwabc@nate.com).

Jang-wook Kim is a candidate for the PhD, of civil engineering, Hanyang University, Seoul, South Korea (phone: +82-2-2220-0327; fax: +82-2-2292-0321; e-mail: jwkim@sdag.co.kr).

of sensors, which are positioned at different places of civil structures, should be collected simultaneously and/or sequentially.

Besides, as recent information industry and mobile communication technology are developing, wireless sensor network technique, USN (Ubiquitous Sensor Network), with the concept of Ubiquitous Computing that invisibly provides information to human life with computing, along with mutually cooperating, compromising and connecting networks each other by having subminiature computers within all objects around us is being tried mainly by the information and communication industry. Therefore, the depth of permeability of concrete by frequencies and the effect of the pitch of steel bars with embedding Active RF wireless communication module into concrete for structuring ubiquitous structures as a basic experiment for an application to construction industry were looked into in this study.

For this, specimens were made of concrete and bars that are mostly used in civil and architectural structures and when wireless communication module was installed inside it, the possible communication distance and the intensity of an electric wave were measured. The effect of the length of wavelength of frequencies was analyzed according as the properties of frequency band. It is to suggest the basic data for constructing social infrastructure having the concept of ubiquitous for the real-time monitoring of the level of displacement and damage inside the structure as well as external damage by embedding a wireless sensor in social infrastructure through this.

II. MATERIALS AND DEVICES FOR EXPERIMENTS

A. Materials and Devices for Experiments

How much steel bars and concrete that are the main materials of the construction of structures affect on transmitting and receiving of electric waves was analyzed as a basic experiment for the field application of wireless sensor network to civil and architectural structures. The possible communication distance by the thickness of wireless communications module installed inside plain concrete and reinforced concrete and the communication distance by the pitch of steel bars were measured and waveform of electric waves by the thickness were measured and the phenomenon of diminution of electric waves was evaluated by using spectrum analyzer and the effect of the length of frequency wavelength according as the properties of frequency band was analyzed.

B. Materials for Experiments

Various sized specimens (ex. 600×600×100(mm) etc.) were made with variables of the concrete thickness, the pitch of steel bars, the direction of electric waves, the intensity of RF power. When making specimens, OPC(Ordinary Portland Cement) that meets KS F 5201 and has specific gravity with 3.15 and fineness with 3,341 and big aggregates that has specific gravity with 2.65, fineness modulus with 2.9, and maximum size with 13mm were used. Small aggregates that have specific gravity with 2.62 and standard sand were used. Meanwhile, deformed bars with the 16mm diameter were placed.

C. Sensor Module

This experiment is a basic one and to see the state of transmitting and receiving of wireless communication module, so that Sensor having the sensor of temperature, illuminance, humidity was used. RF chip of cc2420 was used for sensor module and its frequency band is 2.4GHz and the detailed structure of the sensor is as below (Fig.1).

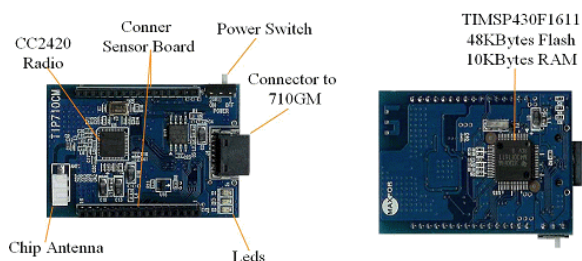

Fig. 1 Structure of Wireless Communication Module

D. Spectrum Analyzer

Spectrum Analyzer used is the equipment indicating the result of measurement by the spectrum of signal or frequency band on a screen and shows what intensity range signals of certain frequency elements have. The unit of horizontal axis is shown as kHz/Div, MHz/Div, which are called Span / Div(frequency span of horizontal axis). Spectrum Analyzer of model R3131A(Fig.2) was used in this experiment and frequency with 2.4GHz, Span/Div with 50MHz, and the result value was represented with dBm(the intensity of electric waves).



Fig 2. Spectrum analyzer

III. METHODS OF EXPERIMENTS

A. Fabrication of Specimen

To experiment the capability of wireless communication in plain and reinforced concrete, the base plate that was grooved to put a module and plain concrete specimens with various thickness (Fig. 3) were made and concrete was placed with steel bars in the pitches of 5, 7, 10, 15cm respectively. The mixture of concrete followed KS standard mixture and when placing concrete, the dimension of a specimen was 600×600(mm) in length and width in case of vertical penetration experiment and five of each 1, 3, 5, 20(cm) by the thickness were made respectively. Besides, the length and width is 600×100(mm) in horizontal direction and five specimens of each 1, 3, 5, 20(cm) by the thickness were made respectively.

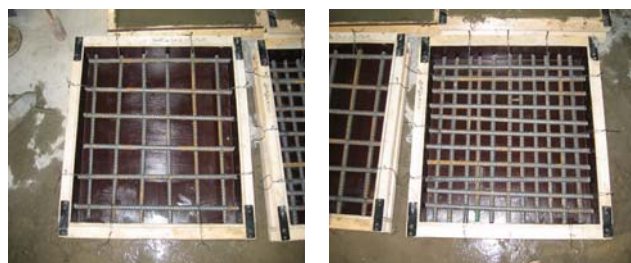

Fig. 3 Placement of Bars (D16@10, D16@5)

B. Permeability Experiment in Vertical Direction

For the experiment of permeability in vertical direction, after putting the base plate on the far bottom in the specially fabricated case, R31 and R15 that have the intensity of RF with 31dB and 15dB respectively were embedded.

For more accurate experiment, transmission module S31 that was specially fabricated to enable only each other communication was embedded one more and the experiment was conducted. Unlike R31, R15 that are transmitted through a computer, if transmission module sent a signal, the lamp itself of reception module would be lit and indicate that transmission and reception are in progress. In addition, the experiment was executed by setting equally RF intensity of both R31 and S31 as 31dB and the comparison between R31 that receives through a computer program and S31, the module of transmission and reception, that was specially fabricated made it possible to experiment with more accuracy.



Fig. 4 Special Case



Fig. 5 Baseplate

The possible distance of reception with piling up concrete plates (Fig.6) was measured in this experiment.



Fig. 6 Permeability Experiment in Vertical Direction

C. Permeability Experiment in Horizontal Direction

In the same way with permeability experiment in vertical direction for the method of this experiment, the depth of permeability in horizontal direction was measured. (Fig.7) The distance of transmission and reception was measured with the baseplate on the right side and piling up in horizontal direction on the left using variously fabricated concrete with thickness of 1, 3, 5, 20cm. The experiment was implemented by using the module of transmission and reception R15, R31, S31 that were used in the experiment of permeability in vertical direction.

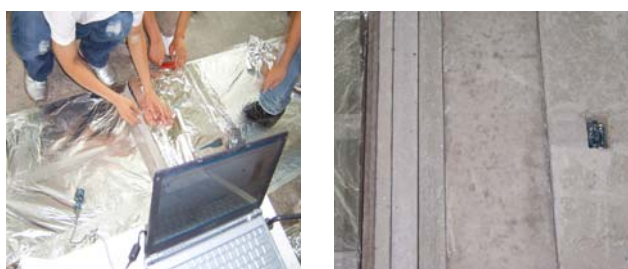

Fig. 7 Permeability Experiment in Horizontal Direction

D. Test of Attenuation of Electric Waves

In the experiment of permeability in vertical and horizontal direction that was conducted above, since it was possible only to check the feasibility of transmission of wireless communication and the intensity of transmission of electric waves wasn't able to be checked, it was impossible to know the accurate intensity and loss of electric waves by the thickness of concrete. For this, the intensity and loss of electric waves by concrete thickness were measured and analyzed using Spectrum Analyzer(Fig.8).

The object of this experiment was R31 that had the biggest intensity of RF. With the same way as the above experiment, spectrum in free space was measured to compare the value of the experiment. Furthermore, it was measured by every 10cm in case of plain concrete and by changing the pitch of steel bars in reinforced concrete.



Fig. 8 Experiment of Measurement of Electric Waves Attenuation

IV. THE RESULT AND ANALYSIS OF THE EXPERIMENT

A. Permeability Experiment in Vertical Direction

The result of permeability in vertical direction is shown in Table 1. In case of R15, it showed 39cm for the depth of permeability in plain concrete and 31cm for D16@5 which the pitch of steel bars was 5cm, 34cm for D16@7 which the pitch of steel bars was 7cm, 36cm for D16@10 which the pitch of steel bars was 10cm, 38cm for D16@15 which the pitch of steel bars was 15cm in reinforced concrete. In case of R31, it penetrated up to 45cm in plain concrete, 37cm for D16@5, 40cm for D16@7, 42cm for D16@10, and 45cm for D16@15. S31 showed the same results. As a result, when R15 and R31 were compared, it suggested that the bigger the intensity of RF is, the more it penetrate.

Moreover, on comparing all of R15, R31, and S31, it penetrated better when the pitch of steel bars was 15cm rather than 5cm and it did the best in plain concrete. And Fig.13 shows that the bigger the pitch of steel bars is, the more the depth of penetration linearly increases, which means wireless communication is affected by the pitch of steel bars. In addition, Fig.14 shows that when the pitch of steel bars is more than 15cm, the pattern of permeability is the same as plain concrete, which means when the pitch of steel bars is more than 15cm, it isn't affected by steel bars.

TABLE I
 THE RESULT OF EXPERIMENT OF PERMEABILITY IN VERTICAL DIRECTION
 (UNIT:CM)

Classification	Con'c	D16@5	D16@7	D16@10	D16@15
R15	39	31	34	36	38
R31	45	37	40	42	45
S31	45	37	40	42	45

B. Permeability Experiment in Horizontal Direction

The result of permeability in horizontal direction is shown in Table 2. It was measured as 43cm in R15, 47cm in R31 and S31 and as the permeability experiment in vertical direction, R31

and S31 with big intensity showed better permeability. Besides, when compared with the permeability experiment in vertical direction, the permeability in horizontal direction was deeper. This suggests effects of the direction by radiation pattern of antenna attached to module and Chip antenna shows similar radiation pattern with monopole antenna that is an unidirectional one and it is also similar with the radiation pattern of the existing small antenna

TABLE II
 THE RESULT OF EXPERIMENT OF PERMEABILITY IN HORIZONTAL DIRECTION
 (UNIT:CM)

Classification	RF15	RF31	S31
Penetration Depth	43	47	47

C. Analysis by the Length of Wavelength of Frequency

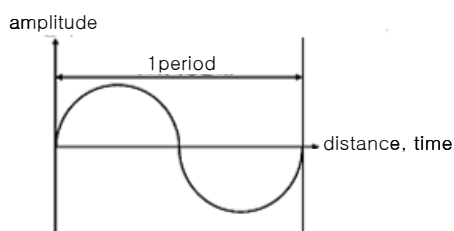

Fig. 17 The Concept of Frequency

Oscillation velocity of a single time (m/s) = $3.0 \times 10^8 \text{ (m/s)} / 2.4 \text{ (number)} \times 10^9 \text{ (number)} = 0.125 \text{ (m/s)}$
 Oscillation distance of a single time (m) = $0.125 \text{ (m/s)} \times 1 \text{ (s)} = 0.125 \text{ (m)}$

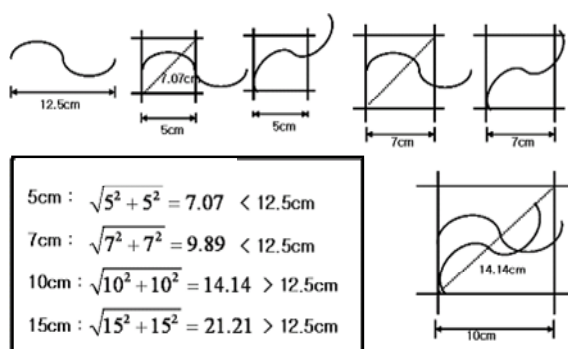

Fig. 18 The Analysis of Wavelength of Frequency

The frequency band used in this experiment is 2.4GHz that oscillates 2.4×10^9 times for one second. In other words, the velocity of electric waves (the velocity of light) per one second should be divided by the times per one second 2.4GHz oscillates to get the oscillation distance of one time. If the velocity of 2.4GHz oscillates one time were calculated, oscillation distance of one time could be obtained by

multiplying it by the time. The velocity of electric waves for one second is $3.0 \times 10^8 \text{ (m/s)}$ and the oscillation frequency of frequency for one second is 2.4×10^9 . In other words, the oscillation velocity of one time is 0.125m/s and the oscillation distance of one time is 12.5cm by 0.125m/s. Besides, the absorption of electric waves of Chip antenna occurs in a conductor less than one wavelength (λ). Namely, the absorption of electric waves happens in the wavelength more than 12.5cm. The result of experiment was analyzed by this.

Finally, it is determined that in reinforced concrete with the pitch of 5cm, 7cm that are less than $12.5 \text{ cm} (\lambda)$, steel bars absorb so much electric waves of wireless communication that communication barrier takes place. Besides, reinforced concrete with the pitch of 10cm is affected in perpendicular direction by the absorption of electric waves but in case of diagonal direction, the distance is 14.14cm which is longer than $12.5 \text{ cm} (\lambda)$. Therefore, it showed that it was not affected. It is considered that reinforced concrete with the pitch of 15cm is not affected by steel bars during wireless communication since it is more than $12.5 \text{ cm} (\lambda)$ in both perpendicular and diagonal direction. These results agree with experiment results of permeability depth and analysis results of attenuation of electric waves of Spectrum Analyzer.

V. CONCLUSION

- (1) The fact that the horizontal permeability was deeper in permeability experiment of plain concrete in vertical/horizontal direction suggests that it penetrates better since the pattern of antenna shows higher value in horizontal direction than in vertical direction with influence of direction of antenna pattern of module used in this experiment.
- (2) As a result of experiment of attenuation of electric waves in wireless communication through spectrum of reinforcement concrete, when the pitch of steel bars was 5cm, it showed -60dBm, -51dBm for 10cm, and -50dBm for 15cm. It showed attenuation of electric waves by 1dBm between the pitch of 15cm and 10cm, 4dBm between 10cm and 7cm, and 4dBm between 7cm and 5cm. Finally, the narrower the pitch of steel bars was, the more attenuation of electric bars occurred and this result indicated that steel bars affects wireless communication.
- (3) It was considered that the phenomenon of attenuation didn't occur since attenuation of -1dBm between the pitch of 10cm and 15cm of steel bars was a delicate difference. Through this result, when wireless is applied to inside structure, if the pitch of steel bars is 10cm, it is not affected by steel bars.
- (4) Since the absorption of electric waves of Chip antenna with 2.4GHz frequency occurs in a conductor with wavelength more than $12.5 \text{ cm} (\lambda)$, steel bars in reinforcement concrete with the pitch of 5cm, 7cm absorb much electric waves in wireless communication, which impedes communication and in case of 10cm, the absorption of electric waves occurs in perpendicular direction, not in diagonal direction. Besides, since reinforcement concrete with the pitch of 15cm has more than $12.5 \text{ cm} (\lambda)$, it is considered that it is not affected by steel bars in wireless communication.

REFERENCES

- [1] Park Seok Kyu, "Detecting Reinforcing Bars under Multi Boundary Layers and Void Shapes in Concrete Using Simulation Analysis Model of Electromagnetic Wave Radar", The KSCE Journal of Civil Engineering, Korean Society of Civil Engineers, 2006, pp.806-816
- [2] Lee Jong Kuk, "The Experimental Study on Wall Sound Transmission Loss of Electric Waves for an Application of RTLS to Construction Field", The KIBC Journal, The Korea Institute of Building Construction, 2009, pp. 95-101
- [3] Hong Seong Wuk, "The Basic Study on Internal Diagnosis of Concrete Slab using Probes of Underground Permeability Radar. The AIK Journal, Architectural Institute of Korea, 2007, pp. 51-58
- [4] Lee Won Jin, "The Transmission Method of Data for Improvement of Reliability of Ubiquitous Sensor Network", Conference Scholarly Monographs, The Institute of Electronics Engineers of Korea, 2007, pp37-38.
- [5] Moon Joon Soo, "The Study on Effective Arrangement of Wireless Network Energy". Conference Scholarly Monographs (III), Korea Information Processing Society, 2004, pp10-12.
- [6] You Ji Yeon, "The Study on Performance Experiment for the Application of RFID/USN Related System to Construction Industry", Conference Scholarly Monographs(III), Korea Institute of Construction Engineering and Management, 2007, pp.800-885