

# Interest of the Sequences Pseudo Noises Codes of Different Lengths for the Reduction from the Interference between Users of CDMA Network

Nerguè Kassahan Kone, and Souleymane Oumtanaga

**Abstract**—The third generation (3G) of cellular system adopted the spread spectrum as solution for the transmission of the data in the physical layer. Contrary to systems IS-95 or CDMAOne (systems with spread spectrum of the preceding generation), the new standard, called Universal Mobil Telecommunications System (UMTS), uses long codes in the down link. The system is conceived for the vocal communication and the transmission of the data. In particular, the down link is very important, because of the asymmetrical request of the data, i.e., more remote loading towards the mobiles than towards the basic station. Moreover, the UMTS uses for the down link an orthogonal spreading out with a variable factor of spreading out (OVSF for Orthogonal Variable Spreading Factor). This characteristic makes it possible to increase the flow of data of one or more users by reducing their factor of spreading out without changing the factor of spreading out of other users. In the current standard of the UMTS, two techniques to increase the performances of the down link were proposed, the diversity of sending antenna and the codes space-time. These two techniques fight only fading. The receiver proposed for the mobil station is the RAKE, but one can imagine a receiver more sophisticated, able to reduce the interference between users and the impact of the coloured noise and interferences to narrow band. In this context, where the users have long codes synchronized with variable factor of spreading out and ignorance by the mobile of the other active codes/users, the use of the sequences of code pseudo-noises different lengths is presented in the form of one of the most appropriate solutions.

**Keywords**—DS-CDMA, multiple access interference, ratio Signal / interference + Noise.

## I. INTRODUCTION

THE reason of this work comes from the request always growing on the frequency spectrum, as much for the wireless telephony that for the networks. This request on the spectrum comes from new applications, like the video high definition, which asks for very high rates of data transmission, up to 100 Mbits/s. The other factor which contributes to this increase in demand is the growing number of users who want to reach the frequency spectrum. Born after the Second World War, the transmissions implementing the spread spectrum, direct sequence DS-CDMA, were limited to the military applications which thus made profitable inherent discretion and the robustness in this kind of communication. They recently experienced a very great development in many civil

fields, in particular for mobile telephony - with the standardization of the UMTS which succeeds the GSM. In this case, they are the possibilities of transmission of several signals in the same or reception frequency band with minimum of interferences and use of a broader frequency band which are thus exploited.

That is not without disadvantage, being given that with the significant number of simultaneous transmission, that one attends interference between the various users. A way of improving the effectiveness would be to allow the users who do not need a so high rate of transmission (images applications only, voice or data) to transmit in the same bandwidth but rate (binary) slower.

That would enable us to adapt much more simultaneous users, and fact of improving the effectiveness of use of the spectrum and of reducing the interferences. The method that we propose to make a success of that is the use of the sequences of codes pseudo noises lengths different or CDMA at multiple rates.

## II. FORMALISME: CASE OF THE CDMA AT SINGLE RATE

### A. Context

In our system DS/CDMA [1] we use the phase modulation (BPSK) with sequences of fascinating bipolar codes pseudo noise of the values of the whole  $\{\pm 1\}$  for spectral spreading out. Each user is independent one of the other. The signal transmitted by the  $K^{eme}$  user is:

$$s_k(t) = \sqrt{2P} a_k(t) b_k(t) \cos(\omega_c t + \theta_k) \quad [2]$$

where  $P = \frac{E_b}{T}$  is the average power  $a_k(t)$  and  $b_k(t)$  are respectively impulses rectangular of duration  $T_c$ , which represents the sequence of codes which spreads out the spectrum of the data and duration  $T$ , which take values of the unit  $\{\pm 1\}$ . The term  $\omega_c$  is carrying,  $\theta_c$  the initial dephasing of the signal,  $T$  and  $T_c$  durations respective of the impulses of data and chips such as  $T = NT_c$  with  $N$  the period (length) of the sequence. The trains of impulses are defined as follows:

Authors are with INPHB-LABTIC 08 BP 1093 Abidjan 08 (Côte d'Ivoire)  
(e-mails: nerguyefi@yahoo.fr, oumtana@nic.ci).

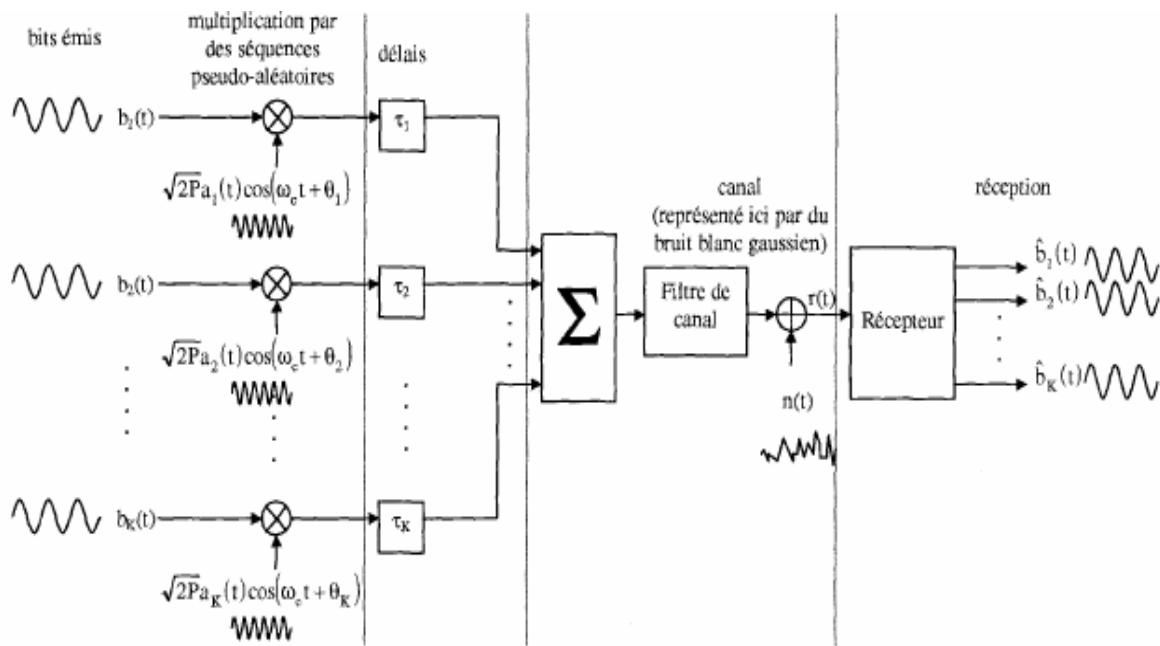

Fig. 1 Model of reception CDMA [2]

$$a_k(t) = \sum_{i=-\infty}^{+\infty} a_k^{(i)} P_{T_c}(t - iT_c) \quad \text{and}$$

$$b_k(t) = \sum_{j=-\infty}^{+\infty} b_k^{(j)} P_T(t - jT) \quad \text{with } a_k^{(i)} \text{ and } b_k^{(j)} \text{ value}$$

in  $\{\pm 1\}$ ; and rectangular impulse height 1 and duration  $T_c$  and  $T$  respectively. The received signal, by considering that the channel is modelled as being a white vibration Gaussian of null average is:

$$r(t) = w(t) + \sum_{k=1}^K \sqrt{2P} a_k(t - \tau_k) b_k(t - \tau_k) \cos(\omega_c t + \theta_k) \quad \text{where } w(t)$$

is a AWGN of null average with a spectral concentration of power  $N_0/2$ ,  $K$  is the number of active users, and  $\tau_k$  is the relative time between the received signal and the beginning of the sequence of die-spreading out with the receiver. The initial times  $\tau_k$  and dephasings  $\theta_k$  are modelled like independent random variables [3] uniformly distributed on  $[0, T]$  and  $[0, 2\pi]$  respectively; by considering that the receiver used is a filter adapted then the exit of receiver  $x$ :

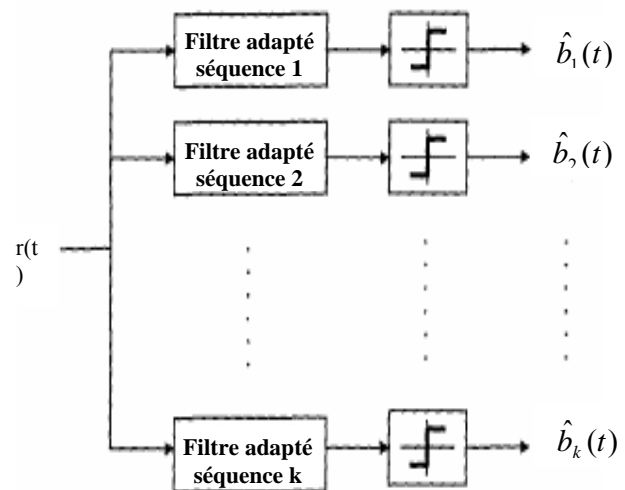

is  $Z_x = \int_0^T r(t) a_x(t) \cos(\omega_c t) dt$  where  $a_x(t)$  is the

sequence of address code of receiver  $x$ :

$$Z_x = \int_0^T [w(t) + \sum_{k=1}^K \sqrt{2P} a_k(t - \tau_k) b_k(t - \tau_k) \cos(\omega_c t + \theta_k)] a_x(t) \cos(\omega_c t) dt$$

$$Z_x = \int_0^T w(t) a_x(t) \cos(\omega_c t) dt +$$

$$\int_0^T \left( \sum_{k=1}^K \sqrt{2P} a_k(t-\tau_k) b_k(t-\tau_k) \cos(\omega_c t + \theta_k) a_x(t) \cos(\omega_c t) \right) dt$$

By dividing the expression of the exit of the receiver into three parts then by supposing that the desired signal corresponds to the user  $\mathbf{k} = \mathbf{x} = \mathbf{1}$  and that the receiver is synchronized perfectly with the desired signal (i.e  $\theta_1 = 0 = \tau_1$ ), then we have:

$$\text{For the Noise } w_1 = \int_0^T w(t) a_x(t) \cos(\omega_c t) dt$$

For the Signal

$$s_1 = \int_0^T \left( \sum_{k=1}^K \sqrt{2P} a_1(t) b_1^{(0)}(t) \cos(\omega_c t) a_1(t) \cos(\omega_c t) \right) dt \text{ where}$$

$b_1^{(0)}$  is the received bit. For the Interference (MAI)

$$I_1 = \int_0^T \left( \sum_{k=2}^K \sqrt{2P} a_k(t-\tau_k) b_k(t-\tau_k) \cos(\omega_c t + \theta_k) a_1(t) \cos(\omega_c t) \right) dt$$

Our study will relate primarily to the interference MAI.

### B. Study of the Interference MAI

$$I_1 = \int_0^T \left( \sum_{k=2}^K \sqrt{2P} a_k(t-\tau_k) b_k(t-\tau_k) \cos(\omega_c t + \theta_k) a_1(t) \cos(\omega_c t) \right) dt$$

and the equation opposite is that which represents the interference caused by the other active users. By supposing that for the relative times  $\tau_k$ , one poses that one has then  $\cos \varphi_k = \cos(2\omega_c \tau_k + \theta_k) + \cos \theta_k$ , from where the variance of this term is worth:  $\text{var}[I_1] = E[(I_1)^2]$  i.e.

$$\text{var}[I_1] = \sum_{k=2}^K \frac{P}{2} E \left[ \int_0^T (a_k(t-\tau_k) b_k(t-\tau_k) a_1(t))^2 dt \right] \times E[\cos(\varphi_k)^2],$$

$$\text{var}[I_1] = \sum_{k=2}^K \frac{P}{4} E \left[ \int_0^T (a_k(t-\tau_k) b_k(t-\tau_k) a_1(t))^2 dt \right], \text{ for}$$

sequences at single rate (of the same period), it was shown that  $\text{var}[I_k] = \frac{PT^2}{12N^3} \sum_{k=1}^K r_{k,x}$  [4],  $r_{k,x}$  being the parameter

of average interference, it allows an estimate of the contribution of the interference (MAI) in the Signal report/ratio on interference + Bruit (SNIR) of system CDMA defined as follows:  $SNIR = \frac{1}{\left(\frac{K-1}{3N}\right) + \frac{1}{SNR}}$  [5][6] with

SNR the Signal-to-noise report/ratio when only one user is present and it term  $(k-1)/3N$  is the contribution of MAI in the SNIR has the exit of the receiver. It is thus the reference index

which we will use to evaluate the performance of the sequences of codes pseudo-noises different lengths (multiple rates). The MAI term is that which will be affected by the addition of dimension multiple rates to our system. MAI is a function of the codes used for spectral spreading out, especially their characteristics of intra-correlation and inter-correlation. The MAI term, when many users are present, is the prevalent term compared to the SNR (in the SNIR). The choice of the sequences of codes used thus becomes very important for the maximization of the performance of the network.

## II. PERFORMANCE OF DIFFERENT LENGTHS OF THE SEQUENCES PSEUDO NOISE CODES

The signal transmitted becomes  $s_{ik}(t) = \sqrt{2P_i} a_{ik}(t) b_{ik}(t) \cos(\omega_c t + \theta_{ik})$  with  $a_{ik}(t)$  from duration  $T_i$  and  $b_{ik}(t)$  duration  $T_C$  and period  $N_i$ , user  $\mathbf{k}$  of under system  $\mathbf{i}$ , and  $E_b = P_i T_i = P_j T_j$ , the average power of the signal is different for each rate from data transmission in order to keep constant energy by symbol  $E_b$  [7]. Under system made up of of the same sequences length is a unit thus correspondent with a precise application. The

received signal is form  $r(t) = w(t) + \sum_{i=1}^P \sum_{k=1}^{K_i} s_{ik}(t - \tau_{ik} T)$

$$r(t) = w(t) + \sum_{i=1}^P \sum_{k=1}^{K_i} \sqrt{2P_i} a_{ik}(t-\tau_{ik}) b_{ik}(t-\tau_{ik}) \cos(\omega_c t + \theta_{ik}) \text{ where}$$

$K_i$ , represent the number of users in subsystem  $\mathbf{i}$ ,  $P$  is the number of under system present. Thus the exit of the receiver  $\mathbf{h}$  of the subsystem  $\mathbf{j}$ , is form

$$Z_{jh} = \int_0^T r(t) a_{jh}(t) \cos(\omega_c t) dt \text{ the MAI term is following}$$

it while supposing that the receiver is synchronized perfectly on the desired signal i.e.  $ik = jh$  and  $\theta_{ik} = 0 = \tau_{jh}$ ,

$$I_{jh} = \int_0^{T_j} \left( \sum_{i=1}^P \sum_{k=2}^{K_i} \sqrt{\frac{P_i}{2}} a_{ik}(t-\tau_{ik}) b_{ik}(t-\tau_{ik}) \cos(\omega_c t + \theta_{ik}) a_{jh}(t) \cos(\omega_c t) \right) dt$$

$$I_{jh} = \sum_{i=1}^P \sum_{k=2}^{K_i} \frac{1}{T_j} \sqrt{\frac{P_i}{P_j}} \int_0^{T_j} a_{ik}(t-\tau_{ik}) b_{ik}(t-\tau_{ik}) a_{jh}(t) \cos(\varphi_{ik}) dt \text{ for}$$

$ik \neq jh$

$$\text{var}[I_{jh}] = E[(I_{jh})^2] = \sum_{i=1}^P \sum_{k=1}^{K_i} \frac{1}{T_j} \frac{P_i}{P_j} E[\cos(\varphi_{ik})^2] E_{b_{ik}, \tau_{jh}}[J_{ik}^2] \text{ where}$$

$$J_{ih} = \int_0^{T_j} a_{ik}(t-\tau_{ik}) b_{ik}(t-\tau_{ik}) a_{jh}(t) dt \text{ with}$$

$$\int_0^T \left( \sum_{k=1}^K \sqrt{2P} a_k(t-\tau_k) b_k(t-\tau_k) \cos(\omega_c t + \theta_k) a_x(t) \cos(\omega_c t) \right) dt$$

$R_{ik,jh}(t_1, t_2) = \int_{t_1}^{t_2} a_{ik}(t - \tau_{ik}) a_{jh}(t) dt$  function of inter-

correlation partielle [8]. From where

$$\text{var}[I_{jh}] = E[(I_{jh})^2] = \sum_{i=1}^P \sum_{k=1}^{K_i} \frac{1}{2T_j^2} \frac{P_i}{P_j} E_{b_{ik}, \tau_{jh}} [J_{ik}^2] \text{ with}$$

$$E_{b_{ik}, \tau_{jh}} [(J_{ik})^2] = \frac{T_c^3}{3T_i} r_{i,k} \text{ thus}$$

$$\text{var}[I_{jh}] = E[(I_{jh})^2] = \sum_{i=1}^P \sum_{k=1}^{K_i} \frac{1}{2T_j^2} \frac{P_i}{P_j} \left( \frac{T_c^3}{3T_i} r_{i,k} \right)$$

knowing that  $T_j = N_j T_c$  and  $T_i = N_i T_c$  and that

$$\frac{P_i}{P_j} = \frac{T_j}{T_i}$$

$$\text{then var}[I_{jh}] = E[(I_{jh})^2] = \sum_{i=1}^P \sum_{k=1}^{K_i} \frac{1}{6N_i^2 N_j} (r_{i,k}) \text{ the}$$

variance of MAI, which is a value standardized on the average power of the signal, can then be inserted in the ratio Signal/Noise + Interference (SNIR).

$$\text{Consequently } SNIR_{multirate} = \frac{1}{\text{var}[I_{jh}] + \frac{1}{SNR}} \text{ this}$$

report/ratio is all the more important as it's denominator is small (negligible) i.e. the variance is thus a function of the parameter  $r_{i,k}$  and lengths  $N_i$  and  $N_j$  sequence of code pseudo-noise.  $r_{i,k}$  being the parameter of average interference for under system i then it is enough to make an estimate by simulation to define an interval acceptable for better an effectiveness of the network of this parameter according to under system and finally the variability the lengths of the sequences of code would allow better a minimization of the variance and then to improve it.

### III. CONCLUSION

This it works arises that the different sequences of code pseudo-noise length can allow an optimization of network CDMA by carrying out a differentiation of the signals and reducing the possible interferences between users.

### REFERENCES

[1] Houda KHERDHER ? Mémoire pour grade de maître ès science : Effet des codes correcteurs d'erreurs sur les systèmes CDMA à taux multiples, Université Laval.  
 [2] Direct sequence spread spectrum sequences par Christophe Boulanger (Sagem-Paris, Rue Watt, 75013 Paris), Gérard Loubet (INPG/LIS, Campus Universitaire, 38402 St Martin D'heres), Jean René Lequepeys (CEA-LETI, CEA GRENOBLE, Rua des Martyrs, 38054 GRENOBLE) et Laurent Ouvry CEA-LETI, Cea Grenoble, Rua des Martyrs, 38054 Grenoble).  
 [3] Statistique d'ordre supérieur pour le traitement du signal, J.L.Lacoume, P.O.Ambland, P.Comon, (Masson, paris, 1997).

[4] Pursley, M.B., "Performance Evaluation for Phase-coded Spread-Spectrum Multiple-Access Communication. Part 1: System Analysis". IEEE Transactions on Communications, Vol 1. COM-25. No. 8, pp. 795-799, Août 1977.  
 [5] Pursley, M.B. et Sarwate, D.V., "Performance Evaluation for Phase-coded Spread-Spectrum Multiple-Access Communication. Part 2: Code Sequence Analysis". IEEE Transactions on Communications, Vol. COM-25, No. 8, pp. 800-803, Août 1977.  
 [6] Pursley, M.B. et ROEFS, H.F.A., "Numerical Evaluation of Correlation Parameters for Optimal Phases of Binary Shift-Register Sequences". IEEE Transactions on Communications, Vol. COM-27, NO. 10, pp. 1597- 1604, October 1979.  
 [7] Ottosson, T. et Svensson, A., "Multi-Rate Schemes in DS/CDMA Systems". Proc. IEEE VTC'95, Chicago, Juillet 1995.  
 [8] Analyse des systèmes linéaires (chapitre 1 à 4) Jean COAT et Jean-Marie Escane.