

Experimental and Computational Analysis of Hygrothermal Performance of an Interior Thermal Insulation System

Z. Pavlík, J. Kočí, M. Pavlíková, and R. Černý

Abstract—Combined experimental and computational analysis of hygrothermal performance of an interior thermal insulation system applied on a brick wall is presented in the paper. In the experimental part, the functionality of the insulation system is tested at simulated difference climate conditions using a semi-scale device. The measured temperature and relative humidity profiles are used for the calibration of computer code HEMOT that is finally applied for a long-term hygrothermal analysis of the investigated structure.

Keywords—Additional thermal insulation, hygrothermal analysis, semi-scale testing, long-term computational analysis

I. INTRODUCTION

CONTINUOUS decrease of fossil fuels supplies and increase in their prices are reflected in the operating expenses of buildings. In this work, we have focused on the possible reduction of operating expenses of older buildings, where the heating costs represent almost 80% of the total energy costs. Non-industrial buildings are one of the biggest consumers of energy and account for 30-40% of the total primary energy used in developed countries, and this consumption is increasing [1], [2], [3]. The energy behaviour of these types of buildings has received a great deal of attention in Europe, and has been the subject of a specific European Directive (2002/91/CE) [4]. This directive states that building energy demand depends on building construction quality, climatology, and the efficiency of the energy systems deployed in the building. With the reference to the sustainable development principles, especially the passive and low energy buildings should be constructed.

Z. Pavlík is with the Department of Materials Engineering and Chemistry, Faculty of Civil Engineering, Czech Technical University in Prague, 166 29 Prague, Czech Republic (phone: +420-2-2435-4371; fax: +420-2-2435-4446; e-mail: pavlikz@fsv.cvut.cz).

J. Kočí is with the Department of Materials Engineering and Chemistry, Faculty of Civil Engineering, Czech Technical University in Prague, 166 29 Prague, Czech Republic (phone: +420-2-2435-5435; fax: +420-2-2435-4446; e-mail: jan.koci@fsv.cvut.cz).

M. Pavlíková is with the Department of Materials Engineering and Chemistry, Faculty of Civil Engineering, Czech Technical University in Prague, 166 29 Prague, Czech Republic (phone: +420-2-2435-4688; fax: +420-2-2435-4446; e-mail: milena.pavlikova@fsv.cvut.cz).

R. Černý is with the Department of Materials Engineering and Chemistry, Faculty of Civil Engineering, Czech Technical University in Prague, 166 29 Prague, Czech Republic (phone: +420-2-2435-5044; fax: +420-2-2435-4446; e-mail: cernyr@fsv.cvut.cz).

Table 1 presents specific energy consumptions dividing buildings into several categories according to the European technical standard ČSN EN 730540-2:2007 – Thermal Protection of Buildings [5]. Since the most of existing buildings do not meet the requirements of the current strict thermal technical standards, there is need to improve the existing structures in order to eliminate thermal bridges and decrease the heat losses.

TABLE I
SPECIFIC ENERGY CONSUMPTIONS OF RESIDENTIAL HOUSES

Energetic type of building	Energy consumptions (kWh/m ² a)	
	Heating systems	Total
Passive house	15	42
Low energy house	50	130
Standard new building	115	170
Old building	220	280

The improvement of thermal performance of existing buildings is usually done by additional exterior thermal insulation systems. In this way, the thermal bridges are fully eliminated what is highly beneficial for the thermal resistance of the reconstructed building envelopes. There were developed many exterior thermal insulation systems taking advantages of assorted types of thermal insulation materials as on organic basis (expanded plastics, wood wool, cork, straw, technical hemp) as well as on inorganic basis (foamed glass, glass and mineral fibers). Particular products differ in thermal resistance, heat capacity, shape, flammability, specific composition of their structure, etc., what in the relation to the designers' requirements assigns the possibilities of their application in building practice.

However, the exterior insulation systems cannot be applied universally. The typical examples represent historical buildings, where the preservation of original architectural view of facades is one of the top interests of conservationists. Also in case of too complex facade surfaces, the exterior systems fail. In these cases, the interior thermal insulation systems find use [6], [7]. However, one must take into account the possible problems of these insulation systems. The main problem is risk of water vapor condensation in thermal insulation layer transported from the interior air. Also the thermal bridges at the contact of external walls and floors are

not fully eliminated. Another problem represents a possible frost damage of external parts of buildings envelopes. Within the design and on-site application of interior thermal insulation systems, all the above given problems must be considered.

In this paper, the functionality of an interior thermal insulation system is tested. This system is based on hydrophilic mineral wool and uses water vapor retarder instead of standard water vapor barrier.

II. SEMI SCALE EXPERIMENT

A. Semi-Scale Testing System

Semi-scale experiments represent relatively new technique for determination of hygrothermal behavior of building structures and their particular components within their exposure to the defined climatic loading. The experiment presented in this paper uses a sophisticated testing device that enables simulation of climatic conditions that are as close as possible to the real climatic conditions on building site. Nevertheless, it still maintains laboratory character, so that the expenses can be kept considerably lower compared to the test house testing. That is why we denote it semi-scale experiment.

A climatic chamber system suitable for simulation of difference climate conditions for building envelope samples with the real thickness and size of its components was developed in our previous investigations [8]. The climatic chamber system consists of two climatic chambers, connected by a specially developed tunnel for placing the studied specimens. The test space is water and vapor proof and thermally insulated. The climatic conditions in the system are controlled by programmable microprocessor that makes possible to simulate relative humidity and temperature corresponding to the real climatic data of the test reference year. Fig. 1 shows the scheme of the climatic chamber system.

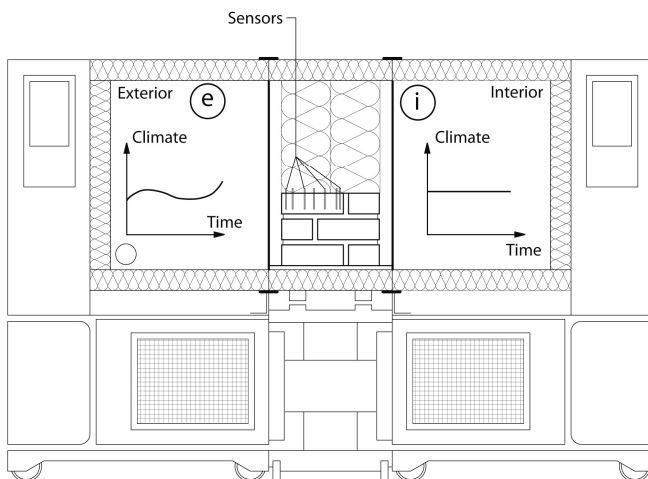

Fig. 1 Scheme of the climatic chamber system

In the presented experiment, monitoring of relative humidity and temperature changes in the specific places of the studied construction detail was done. For this purpose, sophisticated system of probes produced by Ahlborn was used. The

accuracy of particular sensors was as follows: capacitive relative humidity sensors applicable in the range of humidities 5-98 % \pm 2 %, temperature resistance sensors \pm 0.4°C in the temperature range from -20 °C to 0°C, and \pm 0.1 °C in the range from 0°C to 70°C. The whole measuring system was operated by a computer, including the climatic data entry into the exterior climatic chamber.

B. Description of the Investigated Structure and Inbuilt Materials

An interior thermal insulation system was applied on a brick wall fragment including a part of the window frame and glazing. Instead of the polymer water vapor barrier, water vapor retarder was used that eliminates the possible water vapor condensation in the construction. New types of materials for water vapor retarder as well as for thermal insulation layer were designed, manufactured, and tested within the past decade [9], [10] which can be utilized in the system.

The composition of the investigated building envelope was formed from the exterior to the interior by load bearing structure - brick wall 600 mm thick, water vapor retarder on lime-cement basis in the thickness of 10-15 mm, dual density hydrophilic mineral wool insulation material of 100 mm thickness, and water vapor permeable plaster with the thickness of 15 mm. 1-D scheme of the tested building envelope is given in Fig. 2.

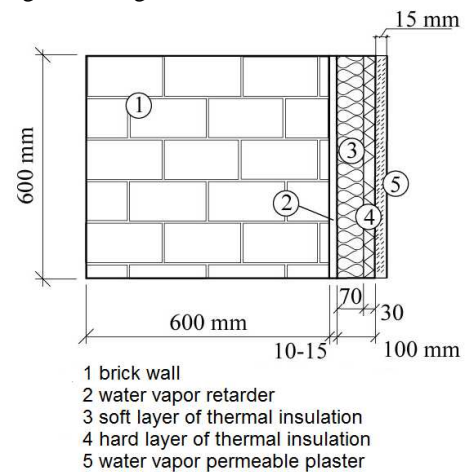

Fig. 2 Scheme of the tested building envelope

TABLE II
 BASIC PROPERTIES OF APPLIED MATERIALS

Material	Bulk density (kg/m ³)	Total open porosity (%)
Ceramic brick	1776	31.8
Water vapor retarder	1321	46.8
Soft layer of thermal insulation	96	96.3
Hard layer of thermal insulation	178	93.1
Interior plaster	1580	46.3

In Table II, there are presented basic physical properties of inbuilt materials. Bulk density was measured gravimetrically and total open porosity was calculated using the matrix density values determined from the Archimedes' weight.

C. Structure Arrangement and Measuring Process

The walling of the studied structure was done in the standard way using dry water vapor retarder and plaster mixtures and wet technological process. Into the studied wall fragment, part of the wooden window frame with glazing was placed in order to study a more complex construction detail. When the sample of the tested building envelope was constructed, the process of sample preparation was divided in two phases: installation of the probes to the sample, and positioning of the sample into the tunnel between the climatic chambers. In our measurements, the combined sensors for monitoring of temperature and relative humidity were used. The accuracy of the relative humidity measurements was tested individually using saturated salt solutions with specified relative humidity. The particular samples were placed into the beforehand bored holes and the upper part of the bore opening was sealed by silicone gel. The placing of the sensors was chosen regarding to the required complex knowledge of temperature and relative humidity distribution and with respect to the possible condensation zone. Figs. 3-6 show sample preparation, application of the insulation system, and sensors placing.

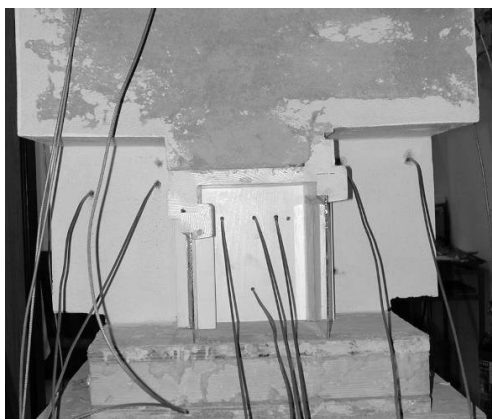

Fig. 3 Sensors placing along the horizontal axis of the wall

After positioning all sensors, the prepared structure was placed into the connecting tunnel, which was then connected by sleeve connectors with the climatic chambers. The structure, placed into the connecting tunnel, was thermally insulated from the tunnel wall using extruded polystyrene boards in combination with mineral wool and provided with a water- and water vapor-proof coating (see Fig. 6). In this way, 1-D moisture and heat transport was ensured.



Fig. 4 Application of the insulation layer



Fig. 5 Plastic net for plaster application

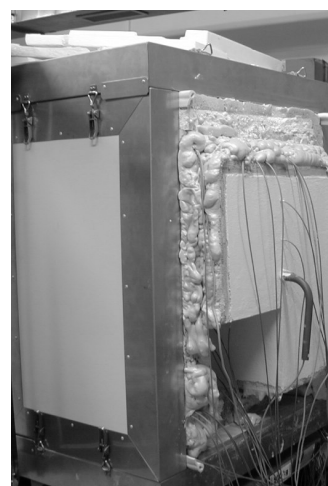

Fig. 6 Studied sample insulated in the testing tunnel

When the climatic chambers were connected, the climatic conditions in both of them were set up. In the chamber, which should simulate interior climatic conditions, the constant

conditions typical for common residential houses were chosen. In the chamber, simulating exterior climatic conditions, the real climatic data of temperature and relative humidity of the reference year for Prague, Czech Republic, were used. The data corresponded to time interval of October 10 to February 14. In this way, the most unfavorable winter climatic conditions were simulated. The exterior climatic data simulated within the semi-scale experiment are given in Figs. 7, 8.

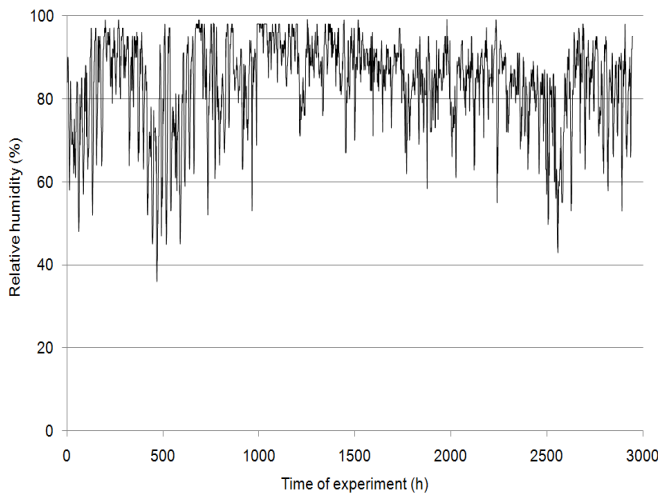

Fig. 7 Exterior relative humidity of the experiment

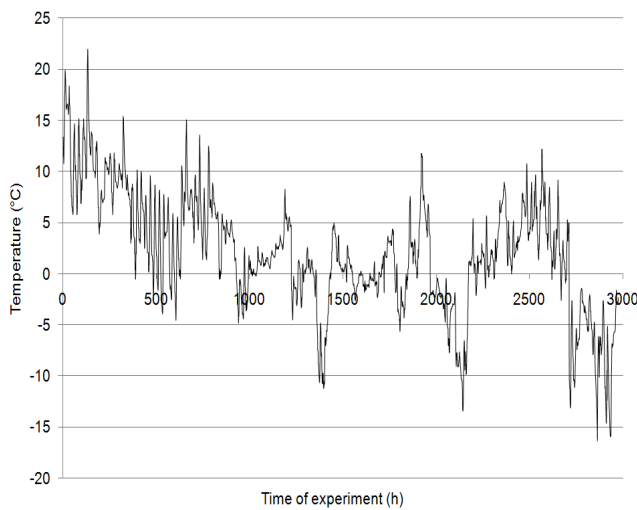

Fig. 8 Exterior temperature of the experiment

III. COMPUTATIONAL ANALYSIS AND CODE CALIBRATION

For the computational analysis of the studied problem, the computer code HEMOT [11] was used. The numerical simulation tool HEMOT has been developed at the Department of Materials Engineering and Chemistry, Faculty of Civil Engineering, Czech Technical University in Prague in order to support coupled heat and water transport in porous building materials. It allows simulation of transport phenomena in constructive building details for 1D and 2D

problems, whereas the basic variables characterizing the hygrothermal state of building constructions (temperature, moisture content, relative humidity) can be obtained as functions of space and time [12]. The mathematical formulation of coupled heat and moisture transport equations is done according to Künzle [13] and the code works on the basis of finite element method.

Within the computational analysis of the studied structure, the calibration of the computer code HEMOT was done at first in order to obtain optimized material parameters for long-term simulations of structure performance. At first, the computer generated mesh was adjusted in sections A-A', B-B', to the positions of the sensors in the measured structure (Figs. 9, 10) so that the same data could be obtained both in the experiment and in the calculations.

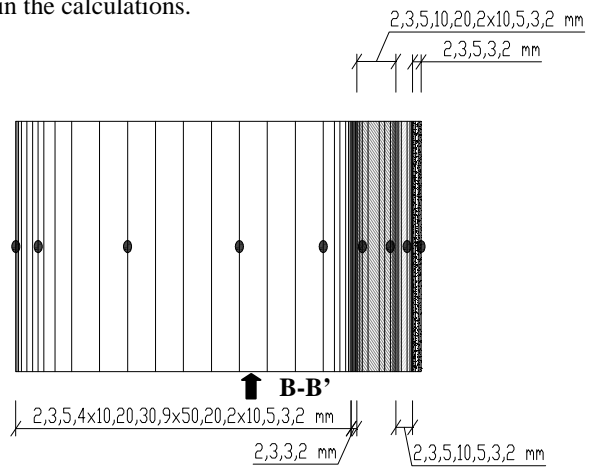

Fig. 9 Sensors placing and computer generated mesh, section A-A'

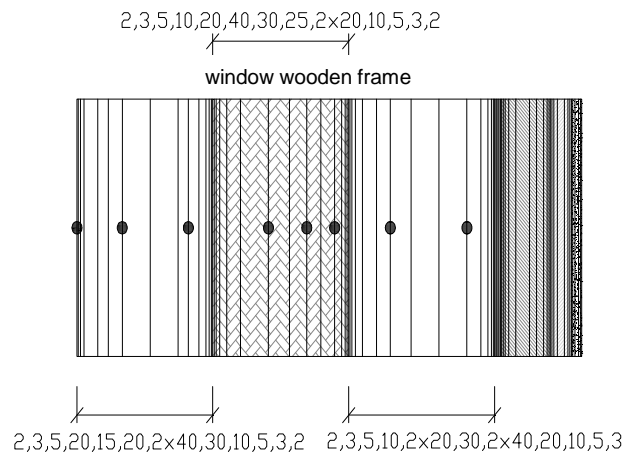

Fig. 10 Sensors placing and computer generated mesh, section B-B'

As input data for computational modeling, material parameters determined in our laboratory during previous experiments were employed [9], [10], [14], [15], except for the material parameters of wooden window frame and air that were taken from the database of the computer code HEMOT. The following parameters were used: bulk density, specific heat capacity, open porosity, thermal conductivity in

dependence on moisture content, apparent moisture diffusivity, sorption isotherms and water vapor diffusion resistance factor. The initial conditions for calculations were chosen as data measured in the semi-scale experiment for time $t = 0$.

After first series of calculations with original data, sufficient agreement between measured and calculated data was obtained for temperature profiles only. On this account, calibration process of HEMOT code was started in order to fit the measured profiles of relative humidity. Within this process, the original moisture transport parameters of particular materials were modified as well as moisture and heat transfer coefficients on both surfaces.

IV. RESULTS AND DISCUSSION

The measured and calculated temperature and relative humidity profiles determined in the calibration tests of HEMOT code for the section A-A' code are presented in Figs. 11, 12.

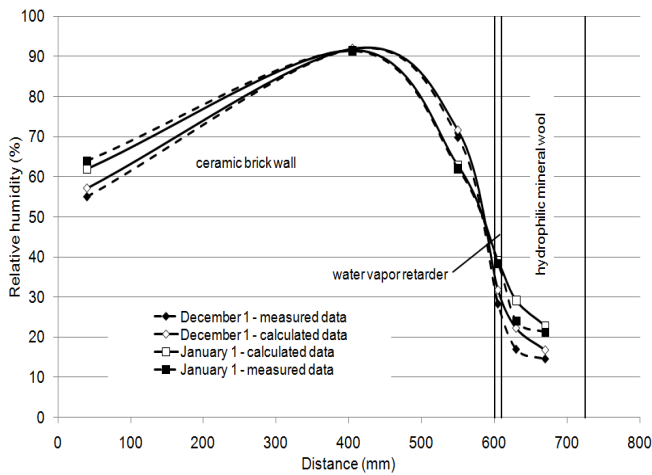

Fig. 11 Relative humidity profiles, section A-A'

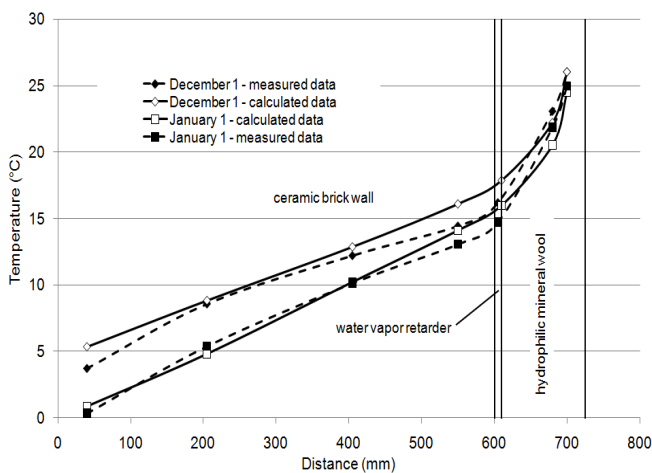

Fig. 12 Temperature profiles, section A-A'

The data given in Figs. 11, 12 were achieved with the optimized parameters given in Tables 3, 4. Within the

calibration procedure we found that the moisture diffusivity must be expressed as function of moisture content in order to get sufficient accuracy of computational simulations.

TABLE III
 MODIFIED HYGRIC PARAMETERS OF STUDIED MATERIALS

Ceramic brick	Moisture diffusivity (m ² /s)	Water vapor diffusion resistance factor (-)
Original parameter	1.52e-09	8.1
Modified parameter	Moisture dependence m ³ /m ³ m ² /s 0.00 - 1.52e-09 0.090 - 5.52e-09 0.315 - 1.52e-08	25.8
Vapor retarder	Moisture diffusivity (m ² /s)	Water vapor diffusion resistance factor (-)
Original parameter	5.43e-08	10.6
Modified parameter	Moisture dependence m ³ /m ³ m ² /s 0.0000 - 5.43e-09 0.0016 - 5.43e-08 0.468 - 5.43e-07	7.0
Mineral wool - soft layer	Moisture diffusivity (m ² /s)	
Original parameter	6.12e-07	
Modified parameter	Moisture dependence m ³ /m ³ m ² /s 0.0000 - 6.12e-07 0.0016 - 9.12e-06 0.96 - 6.12e-05	
Mineral wool - hard layer	Moisture diffusivity (m ² /s)	
Original parameter	1.22e-06	
Modified parameter	Moisture dependence m ³ /m ³ m ² /s 0.000 - 1.22e-06 0.002 - 4.22e-06 0.93 - 1.22e-05	

The final transfer coefficients that were obtained within the fitting process are given in Table 4.

TABLE IV
 MODIFIED TRANSFER COEFFICIENTS

Parameter	Original	Modified
Heat transfer – exterior (W/m ² K)	25.0	35.0
Heat transfer – interior (W/m ² K)	8.0	5.0
Moisture transfer – exterior (s/m)	5.88e-08	5.88e-07

Looking at the comparison of measured and calculated results presented in Figs. 11 – 12, one can see that the differences are very low for temperature as well as for relative humidity profiles. On that account we can conclude, the overall agreement is acceptable for the studied problem and the calibrated code HEMOT can be considered reliable for long-term hygrothermal analysis of investigated building envelope.

V. CONCLUSIONS

Since the code HEMOT was validated and calibrated for the studied structure, long-term simulation of tested building envelope was performed in the final part of the paper. Within these simulations, 3 years cycle of climatic conditions of the Prague reference year was applied on the exterior side of the brick wall provided with newly designed interior thermal insulation system. These results are presented in Figs. 13 – 16. Looking at the thermal function of the investigated envelope fragment, the benefit of the thermal insulation application was quite obvious. This finding basically proved the applicability of the developed insulation system for ceramic brick based building envelopes.

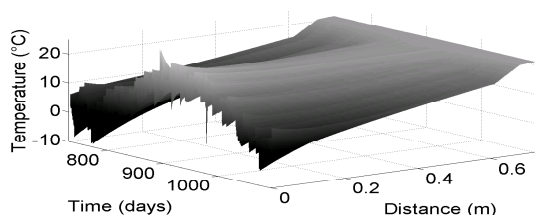

Fig. 13 Temperature distribution in the studied structure during 3rd year of simulation, section A-A'

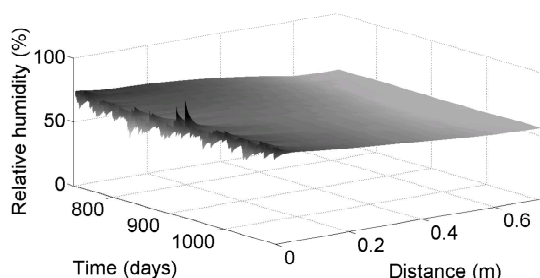

Fig. 14 Relative humidity distribution in the studied structure during 3rd year of simulation, section A-A'

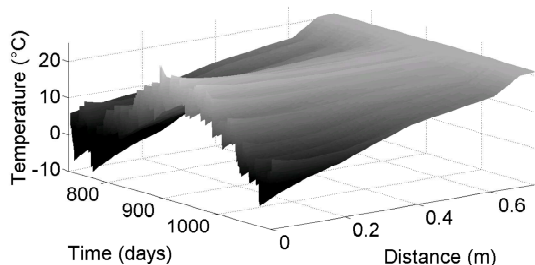

Fig. 15 Temperature distribution in the studied structure during 3rd year of simulation, section B-B'

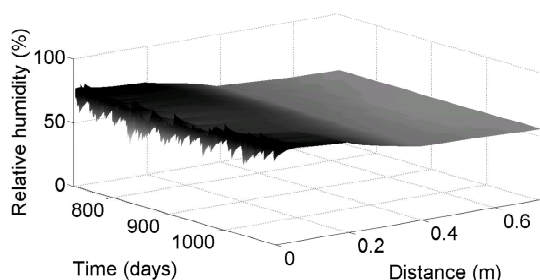

Fig. 16 Relative humidity distribution in the studied structure during 3rd year of simulation, section B-B'

The semi-scale experimental testing and long-term computer simulations of the hygrothermal performance of a brick wall provided with an interior thermal insulation system including hydrophilic mineral wool insulation and water vapor retarder on the surface of the load bearing structure has shown satisfactory thermal and hygric functions of the wall. The experiments and calculations presented in the paper also demonstrated the applicability of semi-scale measurement systems for the verification and calibration of computational models solving the process of coupled moisture and heat transport in building structures. The obtained data revealed the necessity of computer codes calibration before their use for the long-term analyses of structures' performance. Also, the demand on exact determination of thermal and hygric material properties that are used as input data for computational modeling was revealed. Their exact knowledge, optimally in dependence on moisture and temperature changes, is necessary in order to achieve satisfactorily precise data corresponding with the reality of buildings.

ACKNOWLEDGMENT

This work has been financially supported by the Ministry of Education, Youth and Sports of the Czech Republic, under project No MSM: 6840770031.

REFERENCES

- [1] G. Escrivá-Escrivá, "Basic actions to improve energy efficiency in commercial buildings in operation", *Energy and Buildings*, 2011, doi:10.1016/j.enbuild.2011.08.006.
- [2] B. Rosselló -Batle, A. Moia, A. Cladera, V. Martínez, "Energy use, CO₂ emissions, and waste throughout the life cycle of a sample of hotels in the Balearic Islands", *Energy and Buildings*, vol. 42, pp. 547-558, 2010.
- [3] L. Pérez-Lombard, J. Ortiz, Ch. Pout, „A review on buildings energy consumption information”, *Energy and Buildings*, vol. 40, pp. 394-398, 2008.
- [4] European Commission. Directive 2002/91/EC of the European Parliament and of the Council of 16 December 2002 on the energy performance of buildings. *Official Journal of the European Communities*. Online: <http://europa.eu/scadplus/leg/en/lvb/l27042.html>, 2009.
- [5] ČSN EN 730540-2:2007 – Thermal Protection of Buildings – requirements, Český normalizační institut (in Czech).
- [6] Z. Pavlík, R. Černý, "Experimental Assessment of Hygrothermal Performance of an Interior Thermal Insulation System Using a Laboratory Technique Simulating On-Site Conditions", *Energy and Buildings*, vol. 40, no. 5, pp. 673-678, 2008.
- [7] Z. Pavlík, M. Jiříčková, J. Pavlík, R. Černý, "Interior Thermal Insulation System Based on Hydrophilic Mineral Wool", *J. Build. Phys.*, vol. 29, no. 1, pp. 21-35, 2005.
- [8] Z. Pavlík, J. Pavlík, M. Jiříčková, R. Černý, "System for Testing the Hygrothermal Performance of Multi-Layered Building Envelopes", *J. Therm. Env. & Build. Sci.*, vol. 25, no. 1, pp. 239-249, 2002.
- [9] M. Jiříčková, P. Michálek, Z. Pavlík, R. Černý, "Threshold Level Materials on The Basis of Hydrophilic Mineral Wool", *Roczniki Inżynierii Budowlanej*, vol. 10, no. 4, pp. 37-44, 2004.
- [10] M. Jiříčková, R. Černý, "Effect of hydrophilic admixtures on moisture and heat transport and storage parameters of mineral wool", *Const. Build. Mat.*, vol. 20, no. 6, pp. 425-434, 2006.
- [11] R. Černý, (ed.), *Complex System of Methods for Directed Design and Assessment of Functional Properties of Building Materials: Assessment*

and Synthesis of Analytical Data and Construction of the System.
Prague: CTU Press, 2010.

- [12] J. Kočí, J. Maděra, J. Žumár, Z. Pavlík, R. Černý, "Inverse Analysis of Water Vapour Transport in Building Materials Using Genetic Algorithm", in *Proc. 9th Nordic Symp. on Build. Phys.*, Tampere, 2011, pp. 665-672.
- [13] H. M. Künzle, *Simultaneous Heat and Moisture Transport in Building Components*. PhD Thesis, Stuttgart: Fraunhofer IRB Verlag, 1995.
- [14] M. Jiříčková, Application of TDR Microprobes, Minitensiometry and Minihygrometry to the Determination of Moisture Transport and Moisture Storage Parameters of Building Materials, *CTU Report*, vol. 8, no. 2, 2004.
- [15] M. Jiříčková, R. Černý, "Thermal and Hygric Properties of Mortars and Water Vapor Retarders for Interior Thermal Insulation Systems", in *Proc. 11th Symp. for Build. Phys.*, Dresden, 2002, vol. 1, pp. 319-328.