

# Comparison of Multi-User Detectors of DS-CDMA System

Kavita Khairnar, and Shikha Nema

**Abstract**—DS-CDMA system is well known wireless technology. This system suffers from MAI (Multiple Access Interference) caused by Direct Sequence users. Multi-User Detection schemes were introduced to detect the users' data in presence of MAI. This paper focuses on linear multi-user detection schemes used for data demodulation. Simulation results depict the performance of three detectors viz-conventional detector, Decorrelating detector and Subspace MMSE (Minimum Mean Square Error) detector. It is seen that the performance of these detectors depends on the number of paths and the length of Gold code used.

**Keywords**—Cross Correlation Matrix, MAI, Multi-User Detection, Multipath Effect.

## I. INTRODUCTION

THE communication system has challenge of accommodating many users in a small area. The wireless domain is the current area of interest. The conventional systems used either frequency spectrum sharing or time-sharing and hence there was the limitation on the capacity. With the advent of spread spectrum and hence CDMA, fixed bandwidth was used to accommodate many users by making use of certain coding properties over the bandwidth. But this system suffers from MAI (Multiple Access Interference) caused by direct sequence users. Multi-User Detection Technique is going to be the key to this problem. These detection schemes were introduced to detect the users' data in the presence of Multiple Access Interference (MAI), Inter Symbol Interference and noise. Spread spectrum CDMA systems (DS/CDMA) are becoming widely accepted and promise to play a key role in the future of wireless communications applications because of their efficient use of the channel and there allow ness for nonscheduled user transmissions. Hence recent interests are in techniques, which can improve the capacity of CDMA systems.

The CDMA system originally proposed by QUALCOMM for cellular phone applications has been adopted by the Tele-Communication industry association TR-45 committee as TIA/EIA IS-95 standard for cellular communications. As Mobile communication systems based on CDMA are

inherently subject to Multiple-Access Interference (MAI), since it is impossible to maintain orthogonal spreading codes in mobile environments. MAI (Multiple-Access Interference) limits the capacity of Conventional detectors and brings on strict power control requirements to alleviate the Near-Far problem. Multi-user Detector (MUD) techniques exploit the character of the MAI by removal of the Multi-User Interference from each user's received signal before making data decision, and thus offer significant gains in capacity and Near-Far Resistance over the conventional receiver [1].

The DS/CDMA receivers are divided into Single-User and Multi-User detectors. A single user receiver detects the data of one user at a time whereas a multi-user receiver jointly detects several users' information. Single user and multi user receivers are also sometimes called as decentralized and centralized receivers respectively [1]. At the receiver, the aim is to restore the signal, which is corrupted by the channel back to its original form.

In its simplest form, the Single-User detector is a matched filter to the desired signal. Other users' signals are treated as noise (self noise). These self-noise limit the systems capacity and can jam out all communications in the presence of a strong near by signal (Near-Far Problem). The capacity is optimized when all users enter the base station at the same power level forcing the use of power control circuits in the terminal transmitters.

Early work on multi-user detectors assumed that the receiver has the knowledge of the codes of all users. These detectors can be used only for the uplink transmission. However, for downlink transmission, a detection scheme is required that needs only the code of desired user. Detectors based on this principle are known as adaptive multi-user detectors [4, 5].

Multi-user receivers have the potential to significantly improve the performance and capacity of a DS/CDMA system. Interference cancellation is one of the approaches for Multi-User Detection (MUD). Multi-user detection deals with the development and application of joint demodulation and interference cancellation techniques for improved detection of a desired set of digital signals.

Demodulating a given user in a DS/CDMA wireless network requires processing of the received signal to minimize wideband multiple access interference (MAI) caused by other spread spectrum users in the channel.

Verdu's work shows that optimum Maximum-Likelihood Sequence Detector can completely eliminate MAI, thus greatly increase CDMA system capacity. However, the complexity of the Optimum detector is exponential in number of users, which is too complicate for practical implementation. There have been great interests in finding sub optimum

Manuscript received, 15 November 2005.

Kavita khairnar is with the Don Bosco Institute of Technology, Kurla(West) 400070, Mumbai University, Mumbai, Maharashtra, India (e-mail: kavita\_khairnar@rediffmail.com).

Shikha Nema is with V.E.S.Institute of Technology, Chembur 400071, Mumbai University, Mumbai, Maharashtra, India (e-mail: shikhanema@indiatimes.com).

detectors with acceptable complexity and marginal performance degradation compared with the optimum detector. Sub optimum detectors can be classified into two categories, namely linear multi-user detectors and subtractive interference canceller.

Two of the most cited linear multi-user detectors are Decorrelating detector [2] and MMSE detector [3]. In Subtractive Interference Cancellation, estimates of the interference are generated and subtracted out. For Decorrelating detector there is need to compute the inverse of a cross-correlation matrix, which makes it unacceptable for practical implementation. On the other hand, Subtractive Interference Cancellers are much easier to implement compared with linear multi-user detectors, but the performance gap between them is quite obvious. Another disadvantage of subtractive interference cancellation is that they usually need to estimate the amplitude and carrier phase of all active users. Further research is going on the improvement of more efficient schemes.

Earlier multi-user detection techniques are either too complicates to implement in order to achieve near optimum performance, or there is too much compromise in performance to maintain the simplicity of the system. Recently, there has been considerable interest in linear multi-user detection based on Minimum Mean Square Error (MMSE) criterion. It is shown that MMSE detector, relative to other detection schemes has the advantage that explicit knowledge of interference parameters is not required, since filter parameters can be adapted to achieve the MMSE solution. Although it does not achieve minimum bit-error rate, MMSE detector has been proved to achieve the optimal near-far resistance. This paper deals with simulation of linear multi-user detectors methods for varying parameters. In this paper, simulation results are presented to demonstrate the performance of linear detectors viz Decorrelating detector and Subspace MMSE detector. Their performance is also compared with that of conventional detectors. It can be seen that the BER performance is significantly influenced by the number of users, number of paths and length of signature code used. An attempt at reaching certain conclusions has also been carried out.

Fig. 1 shows the general structure of multi-user detector.

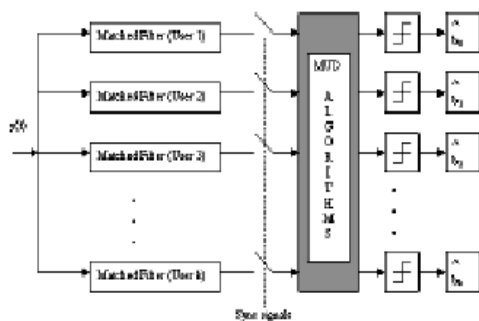

Fig. 1 General Multi-User Detector Structure

The bits are detected by a bank of Matched Filters and thereafter the interference between the different users is suppressed. Different algorithms are used to process the

filtered signal. In linear detectors, before taking the decision of the transmitted bits the outputs of the Matched Filters are combined linearly. In the MMSE receiver, a linear transformation on the matched filter outputs is performed that minimizes the Mean Square Error (MSE), whereas the Decorrelating receiver uses the cross-correlation between the signature sequences.

Multi-user detection is most suitable in the base station due to complexity and other reasons [6]. The computational complexity of the detection is very important for both simulation and implementation point of view. In terms of complexity, the Decorrelator is extremely sensitive to the amount of the update required for the matrix inversion. Between the two cancellation schemes, Successive Interference Cancellation is overall less computationally intensive, but the parallel scheme is more flexible, allowing slower processors in parallel to perform the computation. These approaches can provide significant computational savings at the cost of memory storage requirements. The exact amount of savings will depend on the rate of update required for the correlation matrix.

Sub optimally, the Interference Suppression problem with weighting can be treated as a Least Square (LS) or Minimum Square Error (MSE) problem, thus can be solved iteratively. The complexity of the RLS (Recursive Least Square) adaptive multi-user detector is similar to matrix inverse based Decorrelating detector.

However, the topics such as Neural network, Genetic algorithms based Multi-User Detection techniques, number of issues such as Interference Cancellation combined with Smart Antennas, though are not presented in this paper are as important themselves. As CDMA systems are highly complex, the overall capacity depends on many factors such as power control error, soft handoff, etc whose effects on the capacity are difficult to model. As a result derivation of the capacity and system utilization of the CDMA system are approximate.

Thus in the last two decades a considerable work and research has been done in the area of Multi-User Detection for DS/CDMA environment.

## II. RESULTS AND DISCUSSION

Simulations are carried out considering Conventional detector, Decorrelating detector and Subspace MMSE (Minimum Mean Square Error) detector. AWGN channel is considered and there is perfect power control.

Fig. 2 illustrates the BER performance of the three detectors assuming the parameters Number of paths = 6, length of Gold code = 31 and number of users = 15.

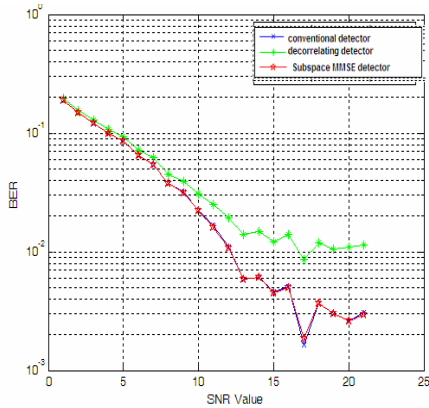

Fig. 2 BER vs SNR (dB) for No. of paths=6, Length of Gold code=31, No. of Users=15

Fig. 3 is plotted under similar conditions except for the number of users (10).

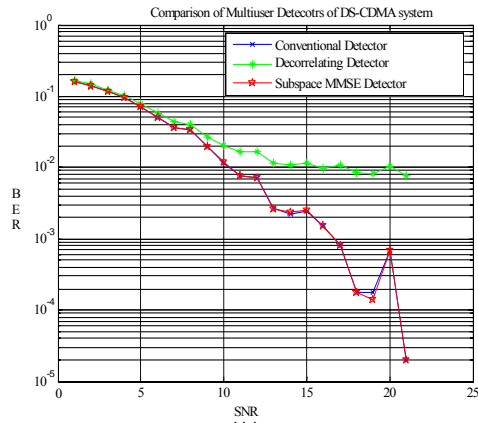

Fig. 3 BER vs SNR (dB) for no. of paths=6, Length of Gold code=31, No. of Users=10

It can be inferred that there is degradation in the overall BER performance. This may be due to increase in the MAI caused by the large number users.

The performance comparison of the three detection schemes can be done by varying the length of the Gold code used (63). The increase in the length of the Gold codes leads to a significant rise of the non-orthogonality of the signature sequences. This leads to a considerable degradation in the system performance as shown in Fig. 4 and 5.

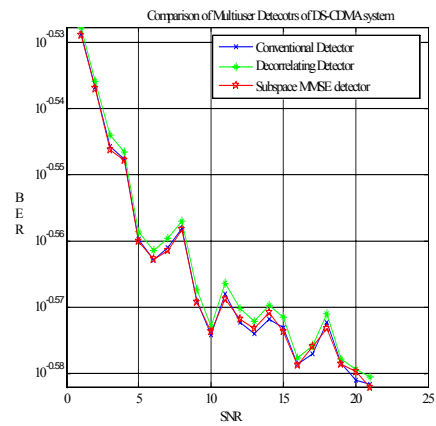

Fig. 4 BER vs SNR (dB) for No. of paths=6, Length of Gold code=63, No. of Users=25

However, the system performs the best when the subspace MMSE detection technique is used. In addition, a significant performance gain is achieved with less number of paths.

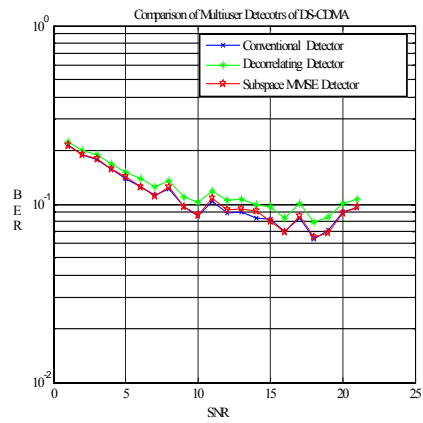

Fig. 5 BER vs SNR (dB) for no. of paths=15, Length of Gold code=31, No. of Users=25

#### REFERENCES

- [1] S. Verdu "Minimum Probability Of Error For Asynchronous Gaussian Multiple Access Channel". IEEE Transactions on Information Theory, Vol. IT-32, pp.85-96, Jan 1986.
- [2] R Lupas and S. Verdu "Linear Multiuser Detectors for Synchronous Code Division Multiple Access Channels "IEEE Transactions on Information Theory, Vol. 35, pp. 23-136, Jan 1989.
- [3] Z. Xie , R. T. Short and C. K. Rushforth " A Family Of Suboptimum Detectors for Coherent Multiuser Communications "IEEE Journal on Selected Areas In Communications, Vol. 8, pp. 683-690, May 1990.
- [4] M. Honig, U. Madhow and S. Verdu "Blind Multiuser Detection" IEEE Transactions on Information Theory, Vol.41, pp. 944-960, July 1995.
- [5] X. Wang and H. V. Poor "Blind Multiuser Detection: A Subspace Approach", IEEE Transactions On Information Theory, Vol.44, pp.677-690, Mar 1998.