

# Development Techniques of Multi-Agents Based Autonomous Railway Vehicles Control Systems

M. Saleem Khan, Khaled Benkrid

**Abstract**—This paper presents the development techniques for a complete autonomous design model of an advanced train control system and gives a new approach for the implementation of multi-agents based system. This research work proposes to develop a novel control system to enhance the efficiency of the vehicles under constraints of various conditions, and contributes in stability and controllability issues, considering relevant safety and operational requirements with command control communication and various sensors to avoid accidents. The approach of speed scheduling, management and control in local and distributed environment is given to fulfill the dire needs of modern trend and enhance the vehicles control systems in automation. These techniques suggest the state of the art microelectronic technology with accuracy and stability as forefront goals.

**Keywords**—Multi-agents, Railway vehicle control system, autonomous design, Train management, Speed scheduling and control.

## I. INTRODUCTION

OVER the last three decades railway vehicle technology has been going improving and in some countries autonomous systems are partially implemented. The modern technology reviewed the subject of Mechatronics and Electronics. Software based computer aided control systems, embedded systems, sensors and data communication technologies have become the essential part for the railway vehicles control and management systems. The general features and benefits of control and monitoring for the railway and transportation vehicles are well understood. The agents based technology is needed in Mechatronics to achieve flexible, network enabled collaboration between centralised and distributed system for high level autonomous vehicle control [1]. The advanced concepts for monitoring and control of railway vehicles dynamics can provide better performance to facilitate higher speed, traffic control, time scheduling, environment monitoring and passengers management. The increasing amount of Electronic control reinforces the trend the vehicles dynamics can provide better performance to facilitate higher speed, traffic control, time scheduling, environment monitoring and passengers management.

The increasing amount of Electronic control reinforces the trend. The proposed autonomous system gives the solution of track condition with the acceptable ride quality over lower quality tracks, tilting of trains around curved tracks with speed adjustment. The record of history for poor tracks and tilting of trains through curved track to maintain speed according to the requirements needs to be maintained in the existing systems to avoid the risk of overturning and passengers un-comfort [9]. The mobile data link field trials initiated to evaluate the feasibility of digital communication for Advanced Train Control System-ATCS found the best results and suggested the forward error correcting code for the data communications radio link for ATCS [3],[8]. GPRS/GSM based wireless communication strategies between vehicles to vehicles, crossing gates to vehicle, distance mileage allocation to vehicle and vehicle to the main control play a significant role in this system. This communication also helps to monitor the position, distance, speed, acceleration and errors detection. In this paper, time measurement, station location, passengers information, root chart and utilities provision are proposed for starting adjustments. A system for calculation and determination of position, distance travelled/remaining, speed, acceleration/deceleration is suggested. The observations regarding the condition of crossing gates Open/Close, junction track changes, track clearance, tracks condition, vehicle tilting, request acknowledgement from stop/non-stop stations, utilities monitoring, mileage record, environmental monitoring, GPRS/GSM based links and Kalman Filtering technique for tracking and data estimation are proposed [5], [7]. The proposed operational view point is about the implementation of speed control and adjustments, breaking control, stop/move, utility request to station, communication between vehicle to control room and vehicle to vehicle.

## II. NEED OF ADVANCED TRAIN CONTROL

The development to enhance the capabilities of the train control systems is under progress at various platforms. The evolution of train control methods, key functional requirements including location determination, detection, monitoring, autonomous control, data communication systems, Global Positioning System (GPS) and information processing are the main issues to review the existing train control system technology. In order to enhance safety of train operations new autonomous technology is needed to replace the existing systems [11]. Various architectures and methodologies for executing a train control in safe manner are

M. Saleem Khan is with GC University Lahore Pakistan.  
e-mail: mskgcu@yahoo.com

being tested for implementation [12]. The open system interconnection-OSI model for radio data link communication to vehicle tracking and operational requirements has been suggested [13],[14]. A strategy for designing a network management system is required. Applications of modern command control and communication technology are required for Advanced Train Control System-ATCS [15],[16]. The existing systems need the unified operations in central traffic control with multi sensors conditions monitoring systems, position information systems including transponders and satellite for a two way digital communications network covering rail road, way side switch, detector interfaces and powerful central computer systems [17].The study of railway system with the problem of evaluating the benefits of safety enhancement to avoid rare but catastrophic accidents revealed that advanced train protection systems should have been installed [18]. The integrated control features of automatic train technology being in process, are the continuous communications signalling system to update the driver's limit of authority, train location and route data transmitted to train from track transponders, automatic train protection for full speed, limit of authority supervision and computer based train control systems with real time train scheduling capability [19].

### III. THE REQUIREMENT OF PROPOSED SYSTEM AND THE INITIAL ADJUSTMENTS

In this section, the overall structural requirements of the system are discussed. The overall view of the system requirements is shown in Table1.

#### A. Internet Access and Communication System

A railway Internet communication system can combine a bidirectional satellite link with a distributed system (wireless LAN and optical fibre) on the train. The train running up to 350 km/h needs at least 4 M bits/s in downlink and 2M bits/s in uplink data rates with a GEO stationary satellite. The system is composed of a communication subsystem, a pointing subsystem and a distribution subsystem. The communication subsystem possesses the Antenna, Transmitter, Modem, and router IP connectivity. The pointing subsystem performs the satellite acquisition and tracking. In order to maximize the received or transmitted signal, several elements like IMU-Inertial measurement unit, AGC (automatic gain control) and control unit are required. The distribution subsystem possesses the optical fibre connection between the central server and each train car for signal distribution to the passengers [5].

#### B. Internet Utilities to Passengers

Via the internet the passengers with prepaid cards can be provided a username and password to log on to the system to get web access, voice over IP connectivity and email services. Via railway operator's Internet they can avail of on line games, trip maps and facts, ticket reservations and sales, video streaming and electronic newspapers.

#### C. Close Circuit Television (CCTV)

IP-based video surveillance system can record picture on the train to be monitored by staff in centralized control room to counteract anti-social activities.

#### D. Railway Measurement System

This system implements real time telemetry services for the railway system using the information of equipments for rail wheels, acceleration on train axles, vibrations, monitoring the signals of junction track information JTI, crossing gates CG, track condition TC, track clearance TCL, Request from non-stop stations, mileage record MR, environment monitoring EM, vehicle tilting VT, on track vehicle to vehicle and between vehicle and main control information exchange. This information is help full for vehicle speed control and scheduling [7].The loaded information of the root chart in the system is according to the prerequisite conditions for a particular track as shown in Table 2.

This information is used in speed control and scheduling. At the starting point, pre-loaded information about vehicle root is selected or other information is allowed to be loaded into the system memory by the control room. The manual entry is also allowed with the authentication of the operator identification. This initial information includes the start time, speed schedule, position of stopping stations, locations of junction track change and crossing gates and track condition

TABLE I  
SYSTEM REQUIREMENTS

Starting Adjustments	Calculations	Observations	Operations
<ul style="list-style-type: none"> <li>Time</li> <li>Station</li> <li>Information about passengers</li> <li>Root chart</li> <li>Utilities</li> <li>CCTV</li> <li>Internet</li> <li>Air conditioning</li> <li>Heating</li> <li>Water and food</li> </ul>	<ul style="list-style-type: none"> <li>Position</li> <li>Distance</li> <li>Speed</li> <li>Acceleration/Deceleration</li> <li>Time remaining</li> <li>Distance remaining</li> </ul>	<ul style="list-style-type: none"> <li>Junction-track change</li> <li>Crossing gates</li> <li>Track condition</li> <li>Track clearance</li> <li>Request</li> <li>Acknowledgment from non-stop station</li> <li>Utilities Monitoring</li> <li>Millage record</li> <li>Environment monitoring</li> <li>Vehicle tilting</li> <li>GPRS / GSM</li> </ul>	<ul style="list-style-type: none"> <li>Start/Stop</li> <li>Speed Adjustment</li> <li>Utility request</li> <li>RX / TX with control room</li> <li>Information exchange between vehicles on one track or on adjacent tracks</li> <li>Announcements</li> </ul>

### IV. OVERALL STRUCTURE OF THE PROPOSED RAILWAY VEHICLE CONTROL SYSTEM-RVCS

The proposed system is able to receive the information regarding the request to/from non-stop stations, position, velocity and actual distance covered from mileage record.

TABLE II  
 ROOT CHARTS PRIMARY INFORMATION

SPEED Km/hr	VT	EM	OTI	SRC	JTI	CG	TC	TCL	RAC	CRI
0	-	-	√	√	√	√	-	√	√	√
≤ 20	√	√	√	√			√	√		√
20-40	√	√	√	√			√	√		√
40-60	-	-	√	√			-	√		√
60-80	-	-	√	√			-	√		√
80-100	-	-	√	√			-	√		√
100-120	-	-	√	√			-	√		√
120-140	-	-	√	√			-	√		√
140-160	-	-	√	√			-	√		√
160-180	-	-	√	√			-	√		√

VT: Vehicle Tilting                      EM: Environment Monitoring  
 OTI: On Track Information              SRC: Speed-Root Chart  
 JTI: Junction Track Information        CG: Crossing Gates  
 TC: Track Condition                      TCL: Track Clearance  
 RAC: Request Acknowledge            CRI: Control Room Information

The position, velocity and mileage records help for error correction in speed adjustment. Fig.1 shows the basic block diagram of the system. The speed scheduling and management arrangement is shown in Fig.2 (a) and the arrangement of speed control and adjustment is shown in Fig.2(b).

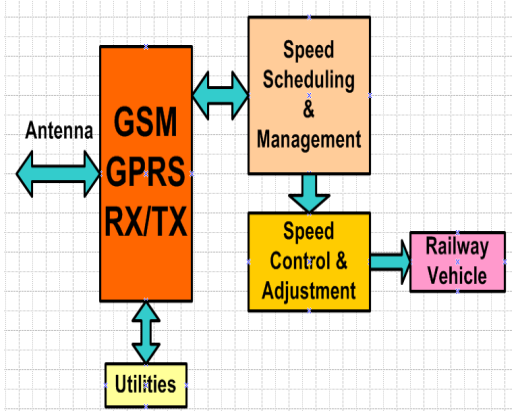

Fig. 1 Basic block diagram of the system.

The scheme of speed scheduling, management, control and adjustment is shown in Fig.3. In this block, links of internal sub- blocks are shown. The proposed design model is shown in the form of various blocks with interlinks in Fig.9(a) and 9(b). The main part of this design strategy is the speed scheduling, management and control system. This whole system is completely autonomous and based on multi-agents. Sensors based monitoring system and data communication system play vital role. Data code correcting techniques and Kalman filters can contribute in the stability and controllability of the overall system. RAM and ROM based storing units can be used for root chart information storage

and incoming and outgoing information records. This arrangement is shown in block format in the design.

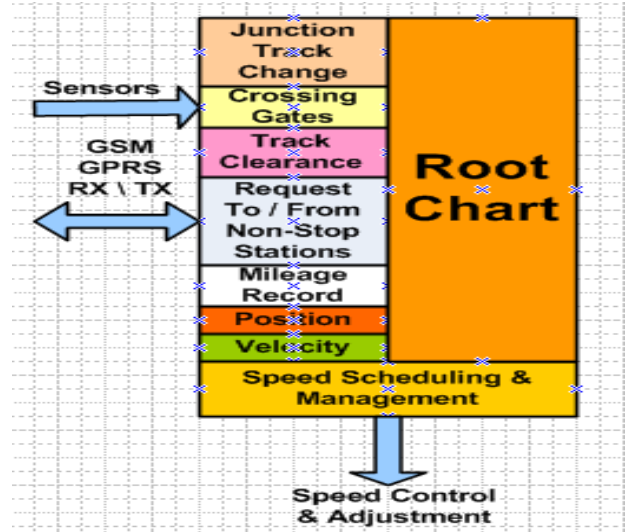

Fig. 2(a) Arrangement of speed scheduling & management

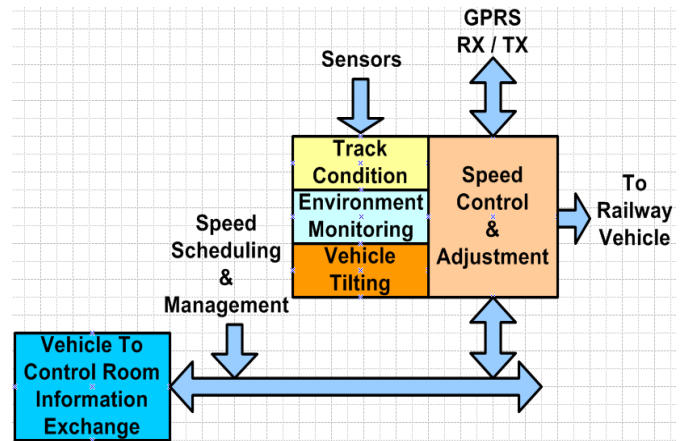

Fig. 2(b) Block arrangement of speed control and adjustment system

An adaptive Kalman filter technique is suggested to control railway vehicle traffic control on the basis of multi-agents information

A. Multi-Agent

Figure 4 shows the links of multi-agents in railway vehicle control system-RVCS. The various conditions monitoring units are called multi-agents because these units get the information from their own resources and overall control the system autonomously according to their control designs. These agents also transmit their information to some parts of the communication system. Therefore, the railway vehicle system is controlled and managed through their participation. The intelligent railway control system can use the structures and cooperative relations of the main agents by using train G-Net operation model [2]. The links of multi-agents in autonomous railway vehicle control system are shown in Fig.4.

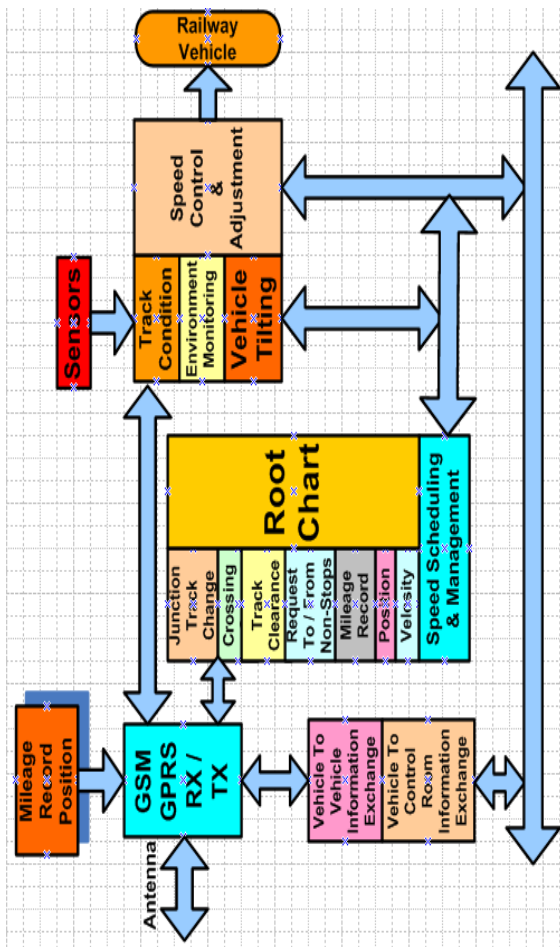

Fig. 3 Scheme of speed scheduling & management, speed control & adjustment systems

### B. Traffic Control

For the vehicular traffic control on a track or on adjacent tracks joining at junction, conditions for normal traffic or rear-end collision must be examined. A mathematical modular approach is proposed for the safe vehicle speed adjustment to reduce any time delay due to any reason i.e. JTC, TC, and CG etc in the journey. The characteristics of mathematical formulation for normal vehicle traffic encountered in practice are proposed for the proper speed control and adjustment. The characteristic behaviour for normal traffic is adapted in the final speed calculations on the basis of vehicle to vehicle and vehicle to control room communication in distributed environment.

$$V = V_m [1 - C/C_m]$$

final speed calculations on the basis of vehicle to vehicle and vehicle to control room communication in distributed environment.

$$V = V_m [1 - C/C_m]$$

When track is empty vehicle concentration  $C = 0$

$V = V_m$ , and maximum speed can be achieved

When vehicle density becomes maximum,  $C = C_m$ .

for the road vehicle traffic, it is called bumper to bumper traffic stop or the velocity of each vehicle is  $V = 0$  and the traffic will be stopped.

If  $C^{\wedge} = C/C_m$  then normalized vehicle concentration is achieved and  $dt / dx = 1/1-2C^{\wedge}$

If vehicles A, B and C are in first, second and third order, their speeds arrangement for normal traffic system should be maintain as  $V_C \leq V_B \leq V_A$ .

The vehicle in front can start and move with the maximum speed on empty track but the following trains behind the first one will adjust their speed within certain limit to recover their time delay. The vehicle speed adjustments depend on track vehicles concentration [4].

The possible ways to increase the speed and improve the synchronisation of trains, need to adapt for the stability of railway networks [10]. This model has the capacity through its speed scheduling unit to include the consideration about random delays of trains and the propagation of delay across the network. This discussion shows that the final speed adjustment in these types of special cases requires the information exchange between vehicles in automation, and another option proposed to be used is to mount high quality SONAR sensors at the front and rear ends of the vehicle to collect the information for the speed estimation. For this part of the circuit, Kalman filters play the vital roles in data estimation for proper speed adjustments. This information should be accurate and without any noise or delay. The mechatronics uses the electronics components and tools together with the mechanical systems. High-tech electronics is increasingly being used to develop such systems in automation but the low cost solutions for the specific tasks need to be developed [2]. In this regard, FPGAs are playing a significant role to develop high performance circuits with the added re-programmable feature [20].

### C. Adaptive Kalman Filtering

This whole proposed system of railway vehicle is based on the communicated information. The delivery of precise data is highly recommended for the stability and controllability of the system. The vehicle to vehicle and between vehicle and control room, information management units are used to control the speed of railway vehicle. In this arrangement track condition, environment monitoring and vehicle tilting monitoring systems are designed to control the system.

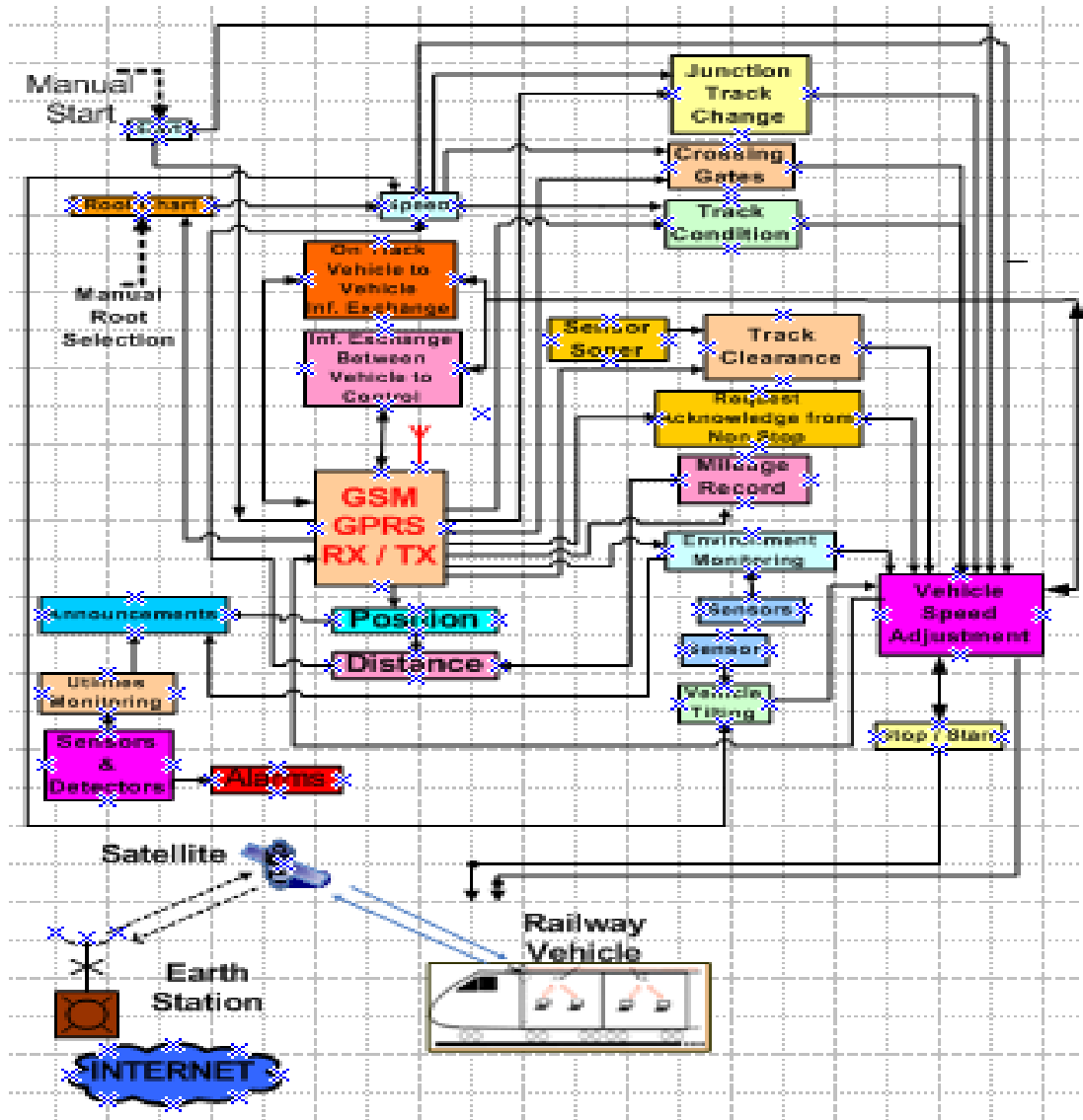

Fig. 4 Links of Multi-Agents in Vehicle Control System

In order to avoid data losses and noise, Kalman filters are the best option to be used at the receiving end of the system. A distinctive feature of the Kalman filter is to describe the mathematical formulation in terms of state-space concepts. Its solution is recursive, each updated estimate of the state is computed from the previous estimate and for new input data only the previous estimate is required to be stored. The pair of process and measurement equations are given as,  
 $x(n+1) = F(n+1,n) + v_1(n)$  ---- (Process Equation)  
 $y(n) = C(n)x(n) + v_2(n)$ ----- (Measurement Equation)  
 Where  $x(n+1)$  is a  $n+1$  state vector and  $y(n)$  is an observation vector.  $v_1(n)$  represents process noise and  $v_2(n)$   
 The signal-flow graph of a linear, discrete dynamical system is shown in Fig. 5.

Fig. 5 describes the estimation of a state vector in a linear model of a dynamical system. Railway vehicle autonomous control system deals with the highly nonlinear data estimation. The extended Kalman filter (EKF) is used for the data estimation of nonlinear model using the extension through

linearization process. This extension is feasible due to the fact, that Kalman filter is described in terms of differential equations (in case of continuous time system) or difference equations (in case of discrete time system).

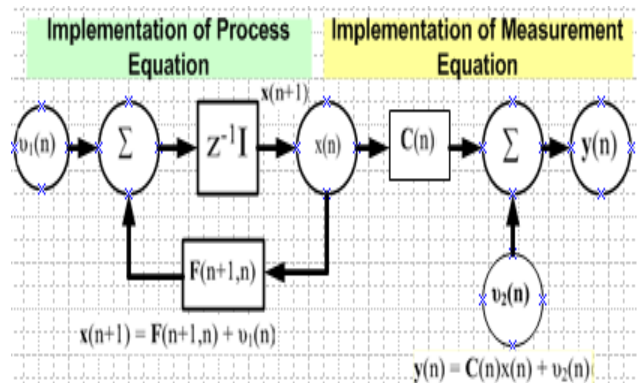

Fig. 5 The signal-flow graph of a linear, discrete dynamical system

A. The summary of the Extended Kalman Filter

Input vector process

Observations = {y(1),y(2),...,y(n)}

Known Parameters:

Nonlinear state transition matrix = F (n, x (n))

Nonlinear measurement matrix =C (n, x (n))

Correlation matrix of process noise vector = Q<sub>1</sub> (n)

Correlation matrix of measurement noise vector= Q<sub>2</sub> (n)

Computation: n=1, 2, 3...

$$G_f(n) = K(n, n-1)C^H(n)[C(n)K(n, n-1)C^H(n) + Q_2(n)]^{-1}$$

$$\alpha(n) = y(n) - C(n, \hat{x}(n | \bar{y}_{n-1}))$$

$$\hat{x}(n+1 | \bar{y}_n) = \hat{x}(n | \bar{y}_{n-1}) + G_f(n)\alpha(n)$$

$$\hat{x}(n+1 | \bar{y}_n) = F(n, \hat{x}(n | \bar{y}_n))$$

$$K(n) = [I - G_f(n)C(n)]K(n, n-1)$$

$$K(n+1, n) = F(n+1, n)K(n)F^H(n+1, n) + Q_1(n)$$

The linearized matrices F(n+1,n) and C(n) are computed from their nonlinear counterparts F (n, x (n)) and C (n, x (n)). The implementation strategy of the extended Kalman filter on the basis of above discussion is available in the most of the literatures available on adaptive kalman filtering [6,22]. One step predictor for the extended Kalman filter is shown in Fig. 6

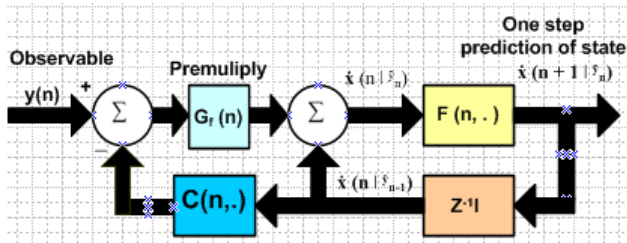

Fig. 6 Extended Kalman filter-one step predictor

The FPGAs based mathematical equations implementation techniques using VHDL or Verilog for various types of filters are being carried out as a forefront goal achievement of digital signal processing with field programming gate arrays [20,21].

V. SPEED SCHEDULING - MANAGEMENT AND CONTROL

The major section of autonomous railway vehicle control system is the vehicle speed scheduling –control and management unit. This unit is used to schedule, manage and control the final speed of the railway vehicle on the basis of all the constraints as shown in fig. 7. The design algorithm for this unit is shown in fig. 8.

The various registers are used as the platforms of the information, collected from root chart memory M, and the various data sources through the receiver of communication unit.

The main tasks of vehicle speed unit are to increase, decrease, stop, and continue the vehicle speed according to the priorities, P1, P2, P3, and P4. Whereas, priority P5 is given to the speed scheduling. The speed control and management unit decides the final speed according to the management of these priorities. The decision boxes, 1, 2, 3, 4, 5, and 6 are the check points to decide the final speed control.

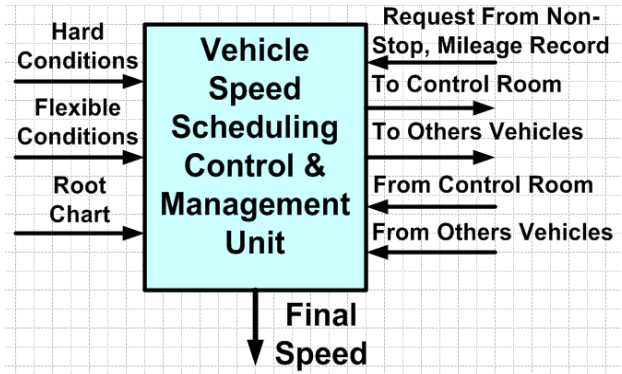

Fig. 7 Vehicle speed block

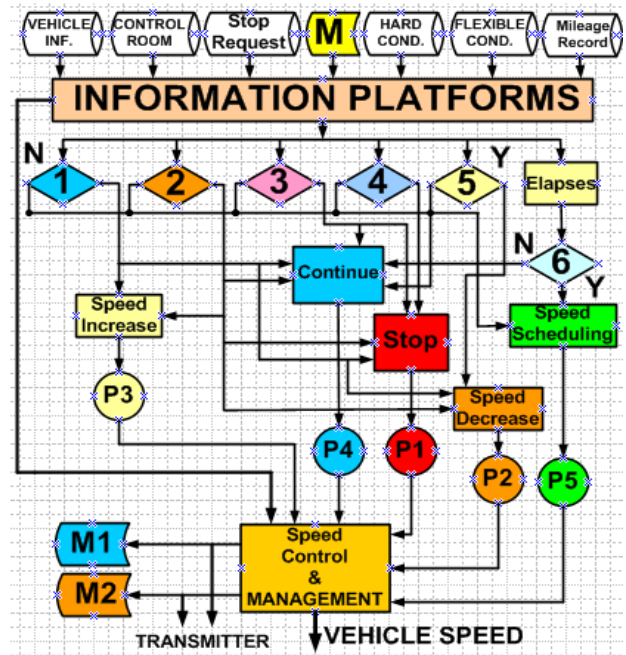

Fig. 8 Design of vehicle speed unit

Check points: 1 is for the information from other vehicle; it allows to increase or decrease the speed or stop the vehicle but in its absence speed scheduling may be processed, 2 is about the information from control room; it also allows to increase or decrease the speed or stop the vehicle but in its absence speed scheduling may be proceeded, 3 for the information regarding non-stop stations; to request for the stop and in its absence speed scheduling may be processed or vehicle may continue its previous state, 4 is to follow the hard conditions regarding; junction track information, crossing gate, and track clearance to stop the vehicle or in absence speed scheduling or the previous state may be continued, and 5 is to follow the

flexible conditions; track condition, environment monitoring, and vehicle tilting, to reduce the speed and in absence to continue the previous state or to scheduling the speed.

This system maintains the record of elapses for speed scheduling. Decision box 6 is used to check time and distance elapses to allow the process of speed scheduling and if there is no elapse than vehicle may continue the previous state.

All the priorities based information and root chart information are given to the speed control and management block for the decision of final velocity.

The information regarding the final status is transmitted to the control room and on track vehicles. This information is also stored in memories M1 and M2.

#### A. Information formats

Simplified information formats for various signals, needed for their acknowledgement and use in vehicle speed unit are shown in Table 3.

TABLE III  
 INFORMATION FORMAT

##### (a) Information of control room

SB	SA	DA	IC	DC	Speed Data	P	EB
----	----	----	----	----	------------	---	----

##### (b) Other vehicle information

SB	SA	DA	IC	DC	Speed Data	P	EB
----	----	----	----	----	------------	---	----

##### (c) Junction track information

SB	IC	DC	DTF	Status	Junction Number	P	EB
----	----	----	-----	--------	-----------------	---	----

##### (e) Request from non-stop station

SB	SA	DA	IC	DC	P	EB
----	----	----	----	----	---	----

##### (f) Mileage record information

SB	IC	DC	Mileage Record	P	E	B
----	----	----	----------------	---	---	---

##### (g) Crossing gate information

SB	IC	Status	P	EB
----	----	--------	---	----

Each of the formats is encapsulated in start bit- SB and end bit- EB, and consists of a parity bit- P for error correction.

Whereas, the other abbreviations used, are given as, SA=Source Address, indicates the on track vehicle code or the control code.

DA=Destination Address, used to indicate the subjected vehicle code.

IC=Information Code, used to indicate the type of information source.

DC=Direction Code, used to give the direction to increase or decrease the speed or to stop the vehicle or continue the previous state. It is information task code.

DTF=Direction of Traffic Flow, useful in case of parallel track where movement of different vehicles on different tracks may be possible.

The length of the each format depends upon the capacity of the whole system. At least 16 bits information code may be used with 8 bits data code, 3 bits for start, end and parity, selecting 1 bit for each.

These digital formats are achieved after the demodulation of the information in communication receiver.

The speed control unit is concerned with: speed data, IC, DC, status code, mileage record, and junction number information in various formats. The rest part of the format is the need of decoders, used in the receiving block of the communication unit.

#### B. Condition Monitoring Strategies.

The various conditions affecting the speed of vehicle are divided into two categories, hard conditions and flexible conditions.

The hard conditions include the junction track information JTI, track clearance TC, and crossing gate CG. JTI and CG are communicated to the system, whereas the TC is monitored by vehicle using SONOR sensors. If any one of them exists, it causes to stop the vehicle and its duration is monitored using time elapse to recover the delay in speed scheduling process.

The flexible conditions include the track condition TC, environment monitoring EM, and vehicle tilting VT. These conditions are monitored on board using the various sensors. These conditions cause the reduction of vehicle speed. Each of these conditions signal follows the look up tables LUTs and selection of least value of them gives the maximum reduction of vehicle speed using speed control unit. The duration of speed reduction is recorded and elapses are contributed afterward in speed scheduling.

## VI. DESIGN MODEL BLOCKS DESCRIPTION

This proposed design of multi-agents based RVCS has the complete autonomy to handle the issues related with the desired root chart travel, various conditions monitoring and speed adjustment, vehicle speed scheduling, management and control, maintain to store the record history of all the information during travel as a black box, vehicle motor power control and motor drive and the provision of communication between main control room and others vehicles on track. It is also capable to receive the information regarding junction track change, crossing gates status, travelled distance mileage, global positioning, speed and request from non-stop stations. In this design the whole system is spread in 16- blocks as shown in Fig. 9(a) and Fig. 9(b).

*Block-1* consists of two RAMs to store the 2 tracks root chart information loaded at the starting station. One information is regarding the current root while another entry is about the root which may be adopted in transit or after the first root as a provision. The entry may be through communication or by manual means. RAM-1 or RAM-2 can be enabled by the data entry selection from block 2. Memory address bus is common for blocks 1 & 3 and provided by memory address counter-1 from block 2.

*Block-2* gives the provision of memory selection for a particular track and data entry. Its root selection unit enables the ROMs in Block 3 and provides the address for memories used.

*Block-3* uses 4- ROMs to have the pre-loaded 4 tracks root chart information. Any one of these 4 roots can be selected through Block 2. The common address is provided by Block

2. The data output lines are common and connected with common root chart memory information bus.

*Block-4* is for hard conditions monitoring and decision about halt. It receives three information: junction track-JTI, crossing gates-CG and track clearance-TCL. JTI and CG may be received through communication system and TCL through SONOR sensors mounted at the front and rear ends of the train. These signals are conditioned and processed for the decision of halt through hard condition decision logic unit. The output of this unit is fed to Block5 for record and Block8 for speed scheduling, management and control.

*Block-5* is for hard condition record. It uses RAM-7 and address counter with clock enable when new entry comes. The output of RAM-7 is connected with Block13 for black box entry.

*Block-6* is for flexible conditions monitoring and speed adjustment. It is called flexible because speed may be changed but not for the system to be halted suddenly. It monitors three conditions: track condition-TC, environment-EM and vehicle tilting-VT through the information received from various sensors used for this purpose. These signals are processed and lowest speed priority adjustment is implemented. Output of this unit is fed to block7 for record entry and Block 8 for speed scheduling, management and control.

*Block-7* is used for the record entry for flexible conditions. It consists of a RAM-8 and address counter with clock enable. Output of this unit is connected with Block 13 for black box entry.

*Block-8* is the main unit of the system. It is used for the speed scheduling, management and control.

The arrangement for calculation and determination of position, distance travelled/remaining, speed, and acceleration/deceleration is suggested. This block has 6 inputs: root chart memory information, hard conditions, flexible conditions, communicated information from main control, vehicle on track and same bandwidth information about junction track change, crossing gates status, distance mileage and non-stop station request on its single input. This block has 3 outputs: one is fed to Block 10 for vehicle power drive for specific speed, second is connected to Block 16 to transmit the information for main control and to Block 9 to store this information and the third output is used for the transmission to the other vehicles on track. This information is also being stored in Block 9.

*Block-9* consists of two RAMs and two separate address counters. RAM-5 is used for storing the information being sent to main control and RAM-6 is used to record the information sent to the other vehicles on track. The common output of these RAMs is fed to Block13 for black box entry.

*Block-10* is used for vehicle power drive. This unit consists of digital to analogue converter-DAC. The input of this unit in digital form is provided by the Block 8, firstly it is converted into analogue form then it is fed to the power control and vehicle motor drive unit to maintain the required speed of the vehicle.

*Block-11* is proposed for storing the received information from main control and on track vehicles. This block consists of two RAMs. RAM-3 is used for storing the main control information and RAM-4 is used to record the information sent

by on track vehicles. These two RAMs are provided the separate address from two clock enable counters. The common output is fed to Block13 for black box entry.

*Block-12* is a communication receiver unit, consisting of four different channels having different bandwidth. Each channel consists of a band pass filter-BPF, demodulator, decoder and Kalman filter. Channel-1 is used for receiving the signal from main control. Channel-2 is for receiving the information from on track vehicles. Channel-3 is set to pass through the information of root chart entry and channel-4 is used to receive the same band width information of JTI, CG, distance mileage data entry, and request from non-stop stations. This block gets the common input entry from a duplexer in Block14.

*Block-13* is the black box of the records of the system. It maintains the record history of all received information to/from control and on track vehicles, hard conditions and flexible conditions faced by the system during travel.

*Block-14* is for duplex antenna. It provides the received signals to Block12 and receives the signal for transmission from Block16.

*Block-15* provides the all the utilities arrangements. In case of any shortage, it sends the information to the near stations or the main control. This unit provides the internet facility to the passengers.

*Block-16* is for communication transmitting arrangements. It consists of a multiplexer, coder modulator and a power amplifier for the signal to be transmitted through antenna in Block14. The information to main control, on track vehicles and utilities provision are multiplexed and processed through this block.

## VII. SYSTEM DEVELOPMENT TECHNIQUES AND THE REQUIREMENT OF FPGAS

Field programmable gate arrays-FPGAs are used due to their high quality performance in digital signal processing and data communication. Using FPGAs in DSP we can achieve adaptive filtering and control tasks [1],[3]. For the system development, many techniques can be used to check the logic of the subsystems. MATLAB Simulink provides the variety of simulation tools to check the subsystems for FPGAs design. Xilinx ISE Design Suite provides the Project Navigator to achieve the design goals and integration with system generator. Using the specific block set all the implementation steps can be performed to generate the FPGA programming files. The System Generator in DSP enables the use of model based design environment of Simulink for FPGAs cores-IPc. The various parts of the system were developed initially with the use of system generator and finally implemented on FPGA by using the IP cores generator.

The various parts of the system were developed initially with the use of system generator and finally implemented on FPGA by using the IP cores generator.

The work on GSM encoding /coding in the FPGA for this specific task is being carried out. The advanced concepts of design structure, and implementation are being used. The sub-system for track condition, environment monitoring and vehicle tilting speed control decoder can be used to achieve



the logic functionalities of the others agents by using System Generator.

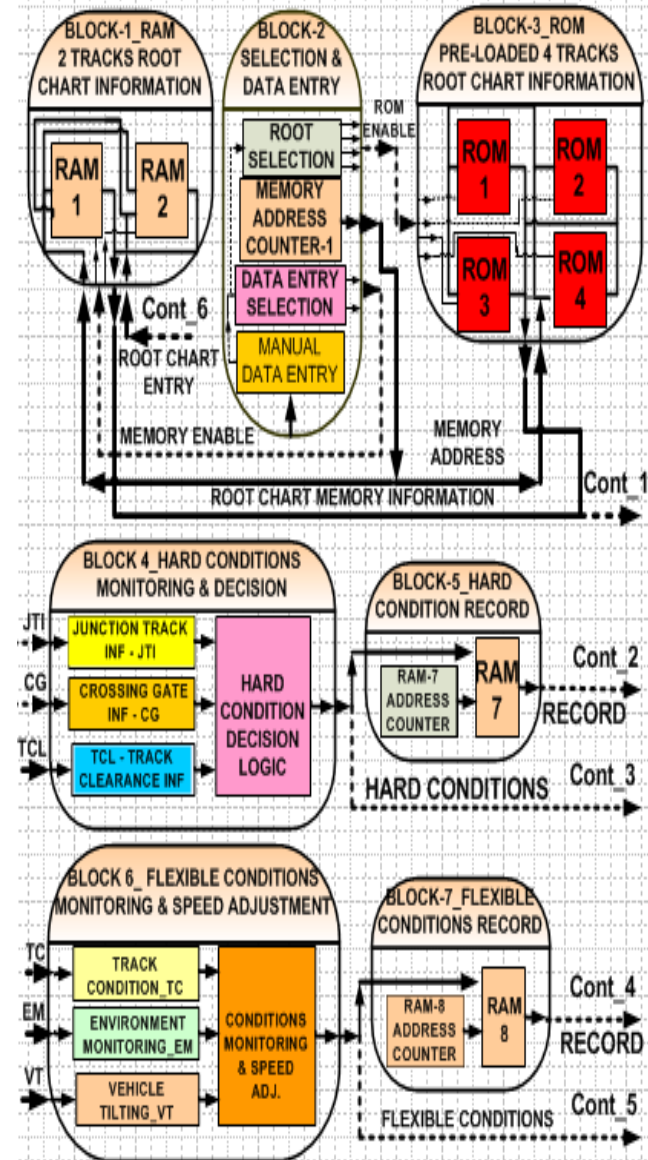

Fig. 9(a) Design blocks of the railway vehicle control system-RVCS

In this regard the concepts of algorithms programming of state machine for this system are needed to be developed. Verilog hardware description language is being used to carry out the project of autonomous railway vehicle control system for FPGAs based control system

### VIII. EXPERIMENTAL WORK AND RESULTS

The experimental set up to design the FPGA for this task was carried out by using ISE 10.1 Foundation Simulator for Spartan 3 XC3s50 FPGA device and found synthesis report ok with no error or warning. HDL synthesis tool XST (VHDL) and IP core generator were used in the design.

Two types of systems were designed; one system provides the communication strategy between vehicle to vehicle, and between vehicles to control, while the other design does not provide this strategy.

### A. Control Strategy of System 1

In this control strategy, communication with other trains and main control is considered. The design structure of FPGA consists of 4-ROMs for the 4 root chart of different tracks selecting one at a time. This provides the versatility of the system to run for different tracks due to its built in provision. Otherwise it has 4-RAMs, capable to be loaded with the roots information. Other 4-RAMs are used for receiving and transmitting facilities between vehicles and vehicle to control

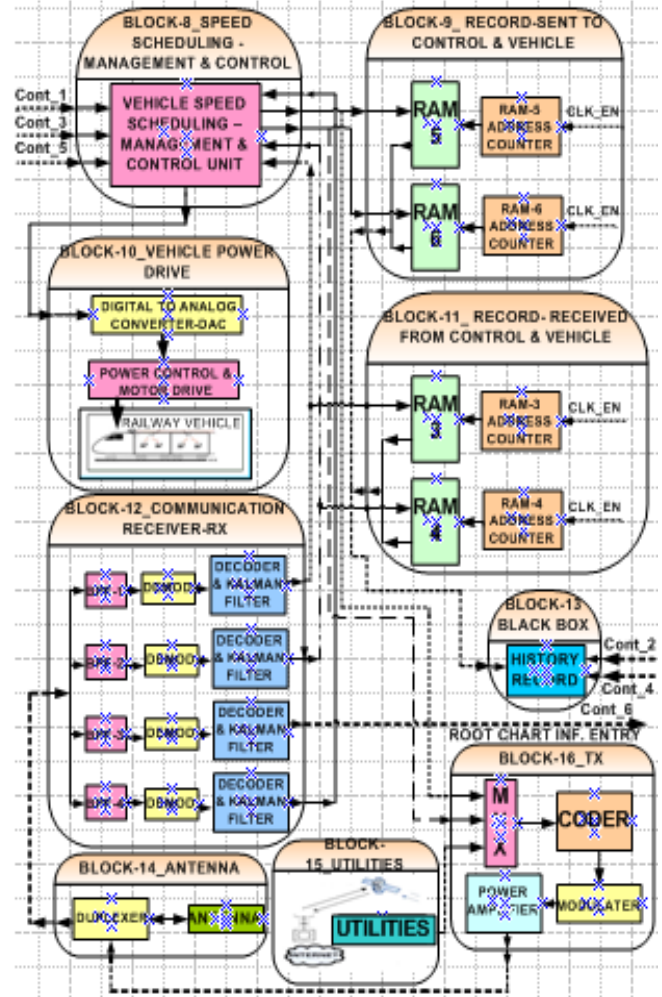

Fig. 9(b) Extension of Fig. 9(a)

room. Two LUTs are used for monitoring the flexible conditions TC, EM&VT and the hard conditions JTC, CS & TCL for the speed control unit. A MUX is used for multiplexing the information. This system is shown in Fig. 10.

### B. Control Strategy of System 2

It consists of 4-ROMs for root chart selection of 4 tracks and 2-RAMs for normal entry of current root and the provision of root change during transaction. It does not have the information communication capability. Two look up tables LUT are used for the hard and flexible condition monitoring. In the both cases internal arrangement was set for the selection of RAM-ROM or MUX inputs. In system-1, one counter and

one decoder were used to select any one of the ROM for pre-loaded root chart information. The address and clock are taken same for RAMs and ROMs.

For data communication, two counters and two decoders were used. These are shown in Fig. 10&11. The pre-loaded information of the root chart is shown in Fig.12, in normal case and in changed environment, shown in Fig.13. In this set up only two stops are shown for equal time stay in a normal case but in the changed environment, two stops according to the same root chart and the two changed environments, one for complete stop and another for speed hurdle are shown Fig.13.

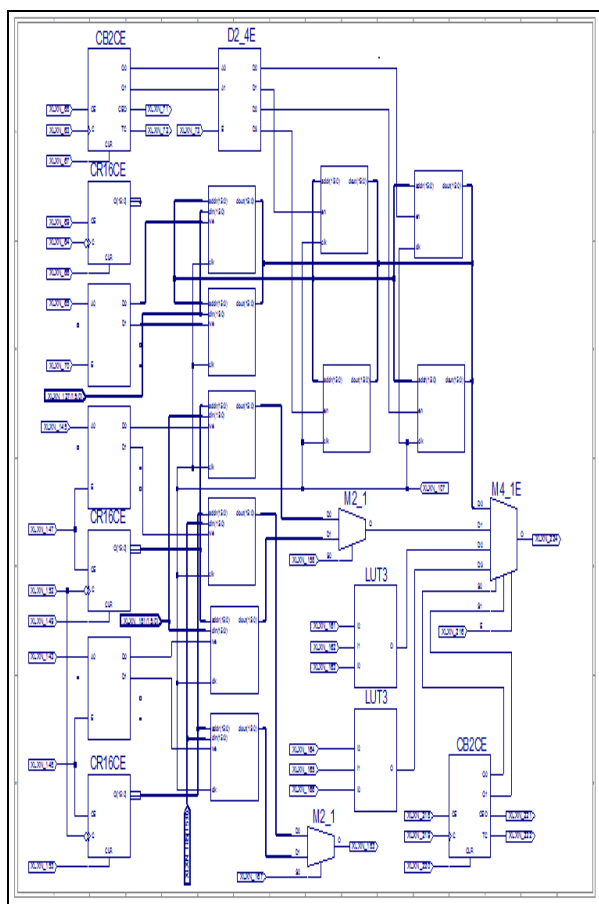

Fig. 10 FPGA design with the link of other vehicles and main control

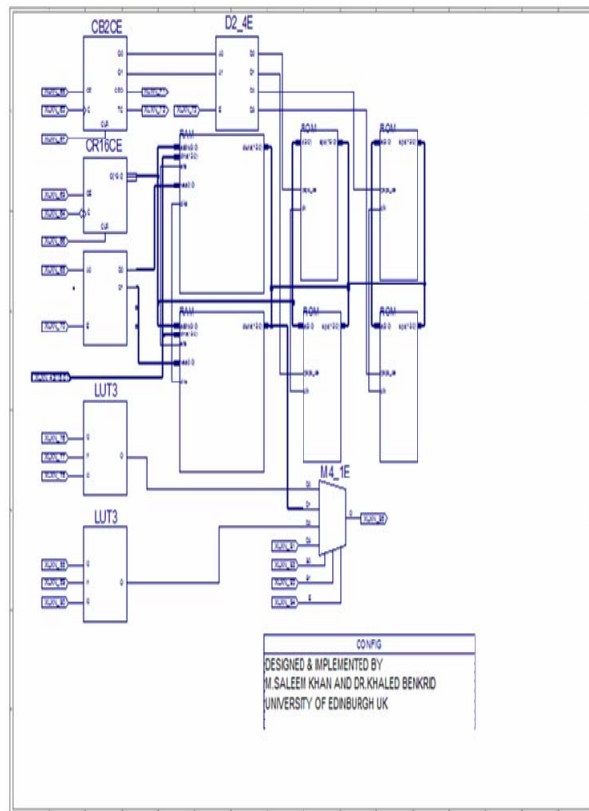

Fig.11 FPGA design without the link of other vehicles and control room

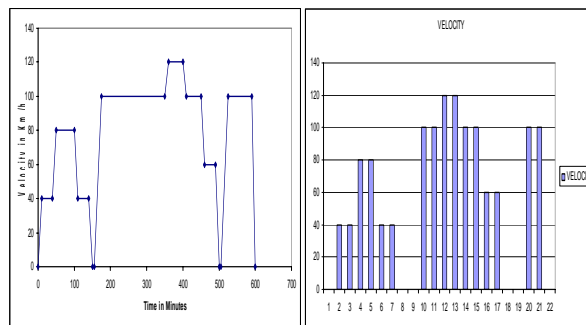

Fig.12 Speed-Time graphs according to the root chart information

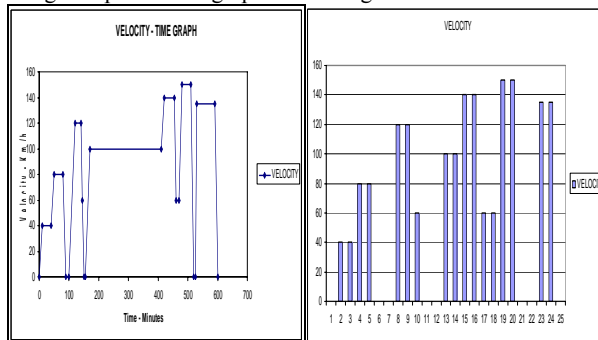

Fig.13 Speed-Time graphs under disturbed environment

### IX. CONCLUSION AND FUTURE WORK

This work provides the vision of highly accurate system for the autonomous control of railway vehicles. Under simulation condition various sub-systems showed the results same as

their design estimation. In future more improved speed scheduling units with priority encoders are needed to be developed, also the improved coding/decoding techniques for communication signals with more precision are needed to be carried out for FPGAs based control systems. This design model can easily be changed for memory expansion and can be implemented using high state of the art microelectronic technology with accuracy and stability as forefront goals. As the system is based on heavy information communication, therefore proper coding and filtering techniques need to be exercised. The development of multi-agents based autonomous railway vehicle control system with verilog hardware description language algorithms for the state machine implementation is the future work in progress.

#### REFERENCES

- [1] R.Harrison,S.M.Lee,"Reconfigurable modular automation systems v for automotive power-train manufacturer",Int Flex Manuf Syst (2006),18:175-190,Springer Science 1March 2007.
- [2] Yangdong Ye, Lei Zhang,"Research on agent based G-Net train groupoperation model", World congress on intelligent control andautomation 2004.
- [3] Ayers, R. G. "Selection of a Forward Error Correcting Code for the Data Communications Radio Link of the Advanced Train Control System". ARINC Research Corp, Annapolis, MD, U.S.Proceedings of the 1988 Joint ASME-IEEE
- [4] Diran Basmadjian,"The Art of Modeling in Science and Engineering", Chapman & Hall/CRC, 1999.
- [5] ACORDE-"Broadband Railway Internet Access on High Speed Trains via Satellite Links",on web sitewhttp://www.railway technology.com
- [6] Simon Haykin,"Adaptive Filter Theory",Pearson,2003
- [7] Ben Schiller,"Model Approach to Running a Railway", FT.com print article, 8June 2008, web site http://www.ft.com,
- [8] Sheikh, Asrar U.; Kraav, J.; Marcos, W. "Mobile Data Link Field Trials: An Evaluation for ATCS". 38th IEEE Vehicular Technology Conference. Philadelphia, PA, U.S.1988.
- [9] Stefano Bruni, T.X.Mei,"Control and Monitoring for Railway Vehicle Dynamics", Vehicle System Dynamics,vol.45, NO. 7-8, July-August 2007, 743-779
- [10] O.Engelhart-Funke,"Analysing stability and investments in railway net works using advanced evolutionar algorithms",Int. Trans. Oper.Res,vol11,No.4,p381-94,July(2004)
- [11] George Achakji, 22a Review of state-of-the Art Train Control System Technology", Transportation Development Centre. Canada. TP 13105E, March1998.
- [12] Ghosh, Anup K, "Distributed Safety-critical System for Real-time Train Control", U.S. Proceedings of the 1995 IEEE 21<sup>st</sup> International Conference on Industrial Electronics, Control, and Instrumentation.
- [13] Coll, David C, "Communications System Architecture of the North American Advanced Train Control System". IEEE Transactions on Vehicular Technology, vol. 39, no. 3, August 1990, pp. 244-255.
- [14] Sheikh, Asrar U. H.; Coll, David C "ATCS: Advanced Train Control System Radio Data Link Design Considerations". IEEE Transactions on Vehicular Technology, vol. 39, no. 3, August1990, pp. 256-262
- [15] Darnell, Janet L.; Colburn, Dorothy A. "ATCS Network Management: A Design Strategy". ARINC Research Corp., Annapolis, MD, U.S. Proceedings of the 1993 IEEE/ASME
- [16] Moody, Howard G. "Advanced Train Control Systems Design and Use". Association of American Railroads, U.S. Proceedings of the 1991 IEEE/ASME Joint Railroad Conference
- [17] Burns, Roger D.; Turner, David B. "Safety and Productivity Improvement of Railroad Operations by Advanced Train Control Systems". 1989 IEEE/ASME Joint Railroad Conference.
- [18] G.Riddington, M. Beck,"Evaluating train protection systems", J.Oper.Res.Soc(UK), vol 55,No.6,p606-13, Jun 2004.
- [19] Richard Cohen,"Agent based train protection automation",Rio Tinto-Report of a Foreign Private issuer, SEC File 1-10533,January 2008.
- [20] U.Meyer, Baese,"Digital Signal Processing With Field Programmable Gate Arrays", Springer, 2006.
- [21] Kaluri, K., Wen Fung Leong, kah-Howe Tan,"FPGA hardware implementation of an RNS FIR digital filter",Conference Record of the Thirty-Fifth Asilomar Conference on Signals, System and Computers, 2001,Vol. 2,pp. 1340-1344.
- [22] Mohinder S. Grewal, Angus P. Andrews, "Kalman Filtering Theory and Practice", Prentice Hall,1993.

**M. Saleem Khan** is an Assistant Professor in GC University Lahore Pakistan. He is currently availing a research fellowship in The School of Electronics & Engineering, University of Edinburgh, UK and completed his PhD thesis in the field of control systems design, simulation and analysis in local and distributed environment.He contributed his services on various projects in the field of Advanced Electronics and Communication. His research interests include control systems design and industrial applications. He promoted a large team of Electronics researchers and organized the field in his country. Mr. Khan had also been served as a senior scientific officer in a classified defense research organization in his country.

**Dr. Khaled Benkrid** is a lecturer in The School of Electronics & Engineering, University of Edinburgh, UK.He is HEA fellow, IEEE senior member, MACM/SIGDA.His research interests are: Custom hardware design, Electronic design automation, construction of optimized compilers, image and video processing and high performance parallel computing. Mr. Benkrid is supervising the research scholars in the fields of advanced Electronics.