

Construction of Attitude Reference Benchmark for Test of Star Sensor Based on Precise Timing

Tingting Lu, Yonghai Wang, Haiyong Wang and Jiaqi Liu

Abstract—To satisfy the need of outfield tests of star sensors, a method is put forward to construct the reference attitude benchmark. Firstly, its basic principle is introduced; Then, all the separate conversion matrixes are deduced, which include: the conversion matrix responsible for the transformation from the Earth Centered Inertial frame i to the Earth-centered Earth-fixed frame w according to the time of an atomic clock, the conversion matrix from frame w to the geographic frame t , and the matrix from frame t to the platform frame p , so the attitude matrix of the benchmark platform relative to the frame i can be obtained using all the three matrixes as the multiplicative factors; Next, the attitude matrix of the star sensor relative to frame i is got when the mounting matrix from frame p to the star sensor frame s is calibrated, and the reference attitude angles for star sensor outfield tests can be calculated from the transformation from frame i to frame s ; Finally, the computer program is finished to solve the reference attitudes, and the error curves are drawn about the three axis attitude angles whose absolute maximum error is just 0.25". The analysis on each loop and the final simulating results manifest that the method by precise timing to acquire the absolute reference attitude is feasible for star sensor outfield tests.

Keywords—Atomic time, attitude determination, coordinate conversion, inertial coordinate system, star sensor.

I. INTRODUCTION

THE attitude determination and control of a space model need to undergo sufficient ground tests as more as possible to reduce research costs, and the same is the case with a star sensor. Most tests about a star sensor regarding local loops are usually carried out in the lab, for example, distortion correction of lens optics 0, imaging parameters calibration [2] (focal length, the origin of an imaging array, rotation angle etc.), single star light simulation by a collimator and multi star lights simulation based on a liquid crystal light valve as well as their imaging tests, hardware and algorithm software tests etc.. Having been qualified for the lab tests, it is time for an initial workpiece of star sensor to have outfield tests, if qualified it is then ready for the subsequent final onboard space test for a test sample.

Tingting Lu is with School of Astronautics, Beihang University, Beijing, 100191 China (corresponding author, phone: +8615010986041; e-mail: tingtingspring@163.com).

Yonghai Wang is with National Key Laboratory of Science and Technology on Test Physics & Numerical Mathematics, Beijing, 100191 China (e-mail: yonghai-wang@163.com).

Haiyong Wang is with School of Astronautics, Beihang University, Beijing, 100191 China (e-mail: why@buaa.edu.cn).

Jiaqi Liu is with National Key Laboratory of Science and Technology on Test Physics & Numerical Mathematics, Beijing, 100191 China.

The outfield tests of a star sensor by imaging real night sky play an irreplaceable role in such aspects as the correctness test of the whole software algorithms and the detective ability test of real star targets [3]. It's the first time for a star sensor initial workpiece to undergo a comprehensive test, in which a high precision reference attitude benchmark is needed for comparison. Outfield tests are different from computer simulation tests, which follow such basic procedures: artificially pre-defining reference attitude standard data, adding some degree of noises and passing through a series of algorithms, and the final error analysis by comparing with the standard data [4]. Yet, what the outfield test lack of is just the test benchmark when simulated star maps are replaced by real night sky star maps. So it is worth studying on a method about a reference attitude benchmark in order to satisfy the need of star sensor outfield tests. This paper will introduce such a method.

II. BASIC PRINCIPLE OF THE ATTITUDE BENCHMARK

A. Definitions of Coordinate Frames

Before describing attitudes, the prerequisite is to set up corresponding coordinate frames. The following five frames that are involved in star sensor attitude determination are introduced [5-7] here the Earth is regarded proximately as a rotating ellipsoid [8].

1. Earth Centered Inertial (ECI) frame i : $o_i x_i y_i z_i$

The origin of frame i is located in the Earth center, with x axis pointing to the vernal equinox Υ , z axis pointing to the north celestial pole and the positive direction of y axis following the right-hand rule.

2. WGS-84 frame w : $o_w x_w y_w z_w$

The WGS-84 frame takes the center of the Earth mass as the origin of the reference ellipsoid, which coincides with the origin o_i of frame i , with z axis pointing to the north celestial pole, x axis pointing to the cross point of 0° latitude and equatorial circumference and the positive direction of y axis following the right-hand rule.

3. Geographic frame t : $o_t x_t y_t z_t$

The origin of frame t is located in the center of gravity o_r , whose x_t axis is on the horizontal plane that passes through o_r , and points to the east direction, y_t axis points to the north direction also on the same horizontal plane, and the positive direction of z_t axis follows the right-hand rule.

4. Platform frame p : $o_p x_p y_p z_p$

The origin o_p of frame p coincides with o_r , whose x_p axis points to the right direction along the platform horizontal axis,

z_i axis points to the up direction, and the positive direction of y_p follows the right-hand rule.

5. Star sensor frame s : $o_s x_s y_s z_s$

The origin o_s of frame s is located in the center of optics, whose z_s axis coincides with the boresight, the $x_s y_s$ plane parallels with the imaging array plane with x_s axis pointing to the horizontal positive direction and y_s pointing to the vertical positive direction and all the three axes follow the right-hand rule.

B. Basic Principle of the Reference Attitude Benchmark

The direct attitude output of a star sensor is relative to the inertial frame i , a kind of absolute space attitude. So, the reference attitude benchmark should also be acquired relative to the same frame i [9].

First, the direction cosine matrix C_{pi} must be first calculated, expressing the platform attitude relative to frame i , which can be obtained by the following steps:

- 1) Calculate the conversion matrix C_{wi} from frame i to w ;
- 2) Calculate the conversion matrix C_{tw} from frame w to t ;
- 3) Calculate the conversion matrix C_{pt} from frame t to p ;

After the above three calculating steps, the reference benchmark matrix C_{pi} can be obtained,

$$C_{pi} = C_{pt} C_{tw} C_{wi} \quad (1)$$

Then the conversion matrix C_{si} from frame i to s can be further got when the mounting matrix C_{sp} of the star sensor is given by calibration,

$$C_{si} = C_{sp} C_{pi} \quad (2)$$

Finally, the reference attitude angles, which consist of the right ascension α and declination δ of the direction of star sensor boresight, and the rotating angle κ of the imaging array plane, can be abstracted from the values of the C_{si} elements [10]. The relationship between the matrix C_{si} and the three attitude angles is set up in the following principle. The formation of matrix C_{si} is taken as the results of three times of rotation from frame i to frame s , each of them can be expressed by a rotation matrix, the first is the $\alpha + \pi/2$ rotation around z_i axis; the second is the $\pi/2 - \delta$ rotation around the changed x_i axis, with z_i coinciding with z_s axis; the third is κ angle rotation around the changed z_i axis after the former two rotations, finally in coincidence with frame s , the rotation angles are as shown in Fig. 1.

The conversion matrix is derived,

$$C_{si} = \begin{bmatrix} C_{11} & C_{12} & C_{13} \\ C_{21} & C_{22} & C_{23} \\ C_{31} & C_{32} & C_{33} \end{bmatrix} \quad (3)$$

where the nine elements can be expressed by the three attitude angles based on the rotation matrix principle,

$$\begin{aligned} C_{11} &= -\sin \alpha \cos \kappa - \cos \alpha \sin \delta \sin \kappa \\ C_{12} &= -\cos \alpha \cos \kappa + \sin \alpha \sin \delta \sin \kappa \\ C_{13} &= \cos \delta \sin \kappa \end{aligned}$$

$$\begin{aligned} C_{21} &= -\sin \alpha \sin \kappa + \cos \alpha \sin \delta \cos \kappa \\ C_{22} &= -\cos \alpha \sin \kappa - \sin \alpha \sin \delta \cos \kappa \\ C_{23} &= -\cos \delta \cos \kappa \\ C_{31} &= \cos \alpha \cos \delta \\ C_{32} &= -\sin \alpha \cos \delta \\ C_{33} &= \sin \delta \end{aligned}$$

Then the three attitude angles can be calculated according to the five elements of the matrix C_{si} ,

$$\begin{aligned} \alpha &= \arctan\left(-\frac{C_{32}}{C_{31}}\right) \\ \delta &= \arcsin(C_{33}) \\ \kappa &= \arctan\left(-\frac{C_{13}}{C_{23}}\right) \end{aligned} \quad (4)$$

The main values domain of them are, $\alpha \in [0, 2\pi]$, $\delta \in [-\pi/2, \pi/2]$, $\kappa \in [0, 2\pi]$, the real value of δ equals to its main value, and the real value of α can be judged by the value of C_{32} and C_{31} , the real value of κ by C_{13} and C_{23} .

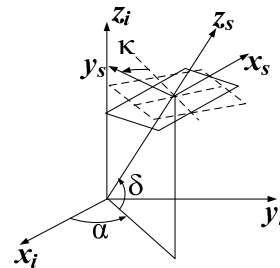

Fig. 1 The geometrical relationship between frame i and frame s

The attitude angles deduced this way can be used as the reference attitude for star sensor outfield tests, and the calculating method of separate conversion matrix will be specified in the following sections.

III. THE ATTITUDE CONVERSION MATRIX C_{wi}

To calculate C_{wi} , the Greenwich hour angle of the vernal equinox (GHA_γ , as shown in Fig. 2) must be got firstly.

GHA_γ ($0^\circ - 360^\circ$) is the spherical angle that increases to the west from the 0° Greenwich meridian of frame w to the longitude line of frame i that passes the vernal equinox, and GHA_γ is also equivalent to the Greenwich Apparent Sidereal Time which can be acquired by means of precisely timing of a clock.

An atomic clock, after necessary time comparing and clock error correction, outputs the International Atomic Time (TAI). Then the Greenwich Apparent Sidereal Time of any observation epoch can be got as follows:

Firstly, the Coordinated Universal Time (UTC) can be calculated from TAI :

$$UTC = TAI - DTAI \quad (5)$$

where $DTAI$ is the accumulated difference value between TAI and UTC , an integral in second, which is routinely provided by the International Earth Rotation and Reference Systems Service (IERS) and can be downloaded from the Earth Orientation Data of the IERS website [11].

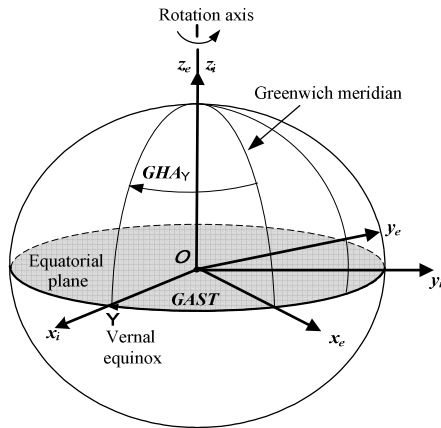

Fig. 2 The Greenwich hour angle of the equinox

Then, the Universal Time ($UT1$) can be obtained from UTC by adding a quantity $DUT1$,

$$UT1 = UTC + DUT1 \quad (6)$$

where $DUT1 = UT1 - UTC$, a difference value between $UT1$ and UTC , can be got from the text file titled IERS Bulletin D Number xxxx of the Earth Orientation Data also on the IERS website [12].

Finally, the Greenwich Apparent Sidereal Time ($GAST$) of the observation epoch ($UT1$) can be got :

$$GAST = GAST_0 + 1.0027379 \times UT1 \quad (7)$$

where $GAST_0$ is the Greenwich apparent sidereal time at the time of 0^h $UT1$, which can be looked up from the table Universal Time and Sidereal Time in the handbook[13]. 1.0027379 is the conversion coefficient between the two kinds of time system.

Here by this way of $GAST$ calculation via an atom clock, the value of GHA_γ can be got, then C_{wi} is expressed as follows,

$$C_{wi} = \begin{bmatrix} \cos GHA_\gamma & \sin GHA_\gamma & 0 \\ -\sin GHA_\gamma & \cos GHA_\gamma & 0 \\ 0 & 0 & 1 \end{bmatrix} \quad (8)$$

IV. ATTITUDE TRANSFORMATION MATRIX C_{tw}

The origin o_w of frame w does not coincide with the origin o_t of frame t . The platform is located firmly on the Earth, whose longitude λ and latitude ϕ can be measured by GPS in a static, repetitive and averaging style during a long period to acquire a high precision.

Needless to consider the distance between the two origins, o_w and o_t , if the angular movement is just treated, because the reference stars are infinite far away from the Earth, the axes need to be rotated two times in order, the first is the rotation of $(90^\circ + \lambda)$ around axis z_w and the second is $(90^\circ - \phi)$ around axis x'_w , finally by two times of basic rotations, frame w coincides with the frame t , and the rotating relation is shown is Fig. 3.

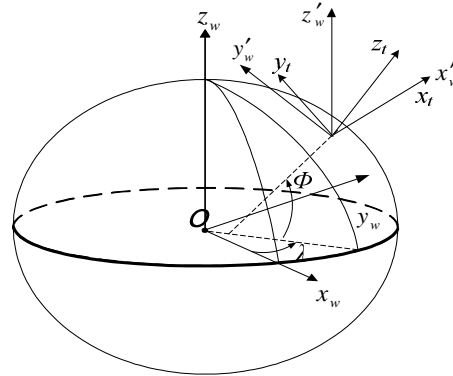

Fig. 3 The relation between frame w and frame t

The attitude conversion matrix from frame w to frame t is expressed as follows,

$$C_{tw} = \begin{bmatrix} -\sin \lambda & \cos \lambda & 0 \\ -\sin \phi \cos \lambda & -\sin \phi \sin \lambda & \cos \phi \\ \cos \phi \cos \lambda & \cos \phi \sin \lambda & \sin \phi \end{bmatrix} \quad (9)$$

V. THE ATTITUDE CONVERSION MATRIX C_{pt}

The origin o_t of frame t coincides with the origin o_p of frame p , the involved variables include the roll angle γ , the pitch angle θ and the heading angle ψ , all of them being of minor value, among which γ and θ can be measured by level indicator and ψ by north-finder devices. As shown in Fig.4, according to the rotation matrix principle, frame t rotates three times in the ψ - θ - γ order to coincide with frame p , so the attitude conversion matrix C_{pt} between frame t and frame p can be calculated as follows,

$$C_{pt} = \begin{bmatrix} a_1 & b_1 & c_1 \\ a_2 & b_2 & c_2 \\ a_3 & b_3 & c_3 \end{bmatrix} \quad (10)$$

where,

$$\begin{aligned} a_1 &= \cos \gamma \cos \psi - \sin \gamma \sin \theta \sin \psi \\ b_1 &= \cos \gamma \sin \psi + \sin \gamma \sin \theta \cos \psi \\ c_1 &= -\sin \gamma \cos \theta \\ a_2 &= -\cos \theta \sin \psi \\ b_2 &= \cos \theta \cos \psi \\ c_2 &= \sin \theta \\ a_3 &= \sin \gamma \cos \psi + \cos \gamma \sin \theta \sin \psi \\ b_3 &= \sin \gamma \sin \psi - \cos \gamma \sin \theta \cos \psi \\ c_3 &= \cos \gamma \cos \theta \end{aligned}$$

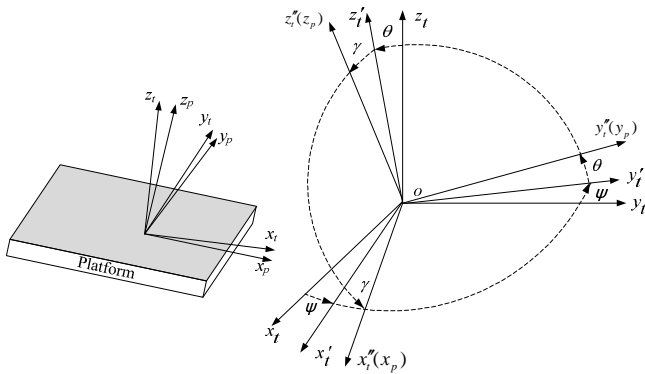

Fig. 4 The relation between frame t and frame p

VI. REFERENCE ATTITUDE CALCULATION BASED ON THE BENCHMARK

According to the principle in sections II to V, the attitude benchmark of the platform relative to frame i can be calculated. To further acquire the reference attitude data for comparison with real outputs of a star sensor, an additional conversion matrix C_{sp} between frame s and frame p need to be determined, which is usually called the mounting matrix resulted from the not precisely installation. The calibration of this constant matrix is often finished in advance in the lab or in the field. Then the reference attitude can be obtained using (1) to (4). The whole process to get the reference attitude is shown in Fig.5.

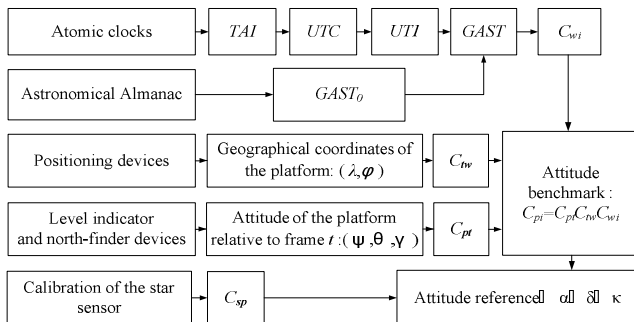

Fig. 5 The whole process to get the reference attitude based on benchmark

VII. PRECISION SIMULATION TESTS

According to the principle to construct the reference attitude benchmark specified in sections II to V and the method to further calculate reference attitudes described in section IV, the computer program is written to solve the values of reference attitudes. The next problem is how to estimate the precision of the test benchmark itself. Considering all the related loops comprehensively, the clock timing loop can acquire a precision so high (the error of $GAST$ is about $1''$) as to be neglected, not of the same order of magnitude requested in the angular measuring area, because the authorized Chinese Astronomical Almanac supplies with the value of $GAST_0$ (the Greenwich apparent sidereal time in 0 epoch of UTI) every day in a year, a sampling period short enough, and the involved parameters in the related equations are downloaded from the IERS website, keeping the latest; the GPS locating error regarding the conversion matrix C_{tw} can be also neglected because the

locating error can reach a level of 2~3mm in a static repetitive averaging measuring style, equivalent with about $0.000001''$ of angular error referring to the Earth center; the key factor lies in the third loop, which is affected by the error of leveling and north-finder instruments, so the following precision test simulations are conducted just for this loop, the bottleneck factor of the whole test system.

Now that the simulation is about error analysis and the fixed deviation angles are of minor value between frame t and p , p and s , the fixed deviation angles can be assigned 0 if considering only the random error of the leveling and north-finder instruments, namely the coincidence of the three frames t , p and s . By this way as proved right theoretically, the form of the equations can be simplified intuitively as (11) which is used to output simulation data, then the conversion matrixes C_{pt} and C_{sp} become unit matrixes. The angle measurement error of the leveling instruments and north-finder can reach to $0.1''$ if the chosen instruments are of the highest precision for a nationwide level and in a repeating and averaging static measuring way.

The other simulating conditions are as follows: the precise geographic position of the static horizontal platform on the Earth is measured by GPS in advance, here let the latitude $\lambda=120^\circ$, and longitude $\phi=40^\circ$, the static locating precision of GPS be 0.2m.

The test time period selected casually is 14:00:00-15:59:59 Dec. 31 2011, during the 120 minutes period one test epoch is sampled every 1 minute, totaling 120 sampling epochs, based on which the reference attitudes in each sampling epoch can be calculated through the computer program introduced in the II to IV sections.

In the process of the apparent sidereal time acquirement, the precise values of $DUTI$ and $DTAI$ of the date Dec. 31 2011 are downloaded from the IERS website, 0.417655s for $DUTI$ and 34s for $DTAI$, $GAST_0$ can be looked up in the Chinese Astronomical Almanac; Then using (5) to (7) the precise values of $GAST_{ref}$ are calculated on every sampling epoch, and further the benchmark attitudes can be obtained by (11)

$$\begin{aligned} \alpha_{ref} &= GAST_{ref} + \lambda \\ \delta_{ref} &= \phi \\ \kappa &= 0 \end{aligned} \quad (11)$$

Having obtained the reference attitudes by the computer program, error analysis of star light determined attitudes can be conducted regarding the random error of the leveling and north-finder instruments. The error curves about the three attitudes (α , δ , κ) are plotted in the following diagrams, Fig.6 to Fig.8.

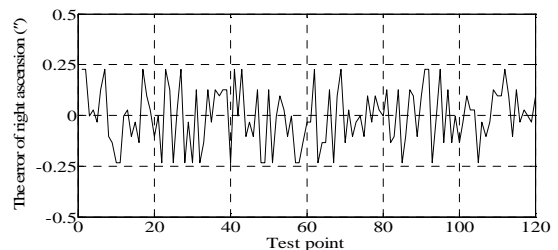

Fig. 6 The error curve of α

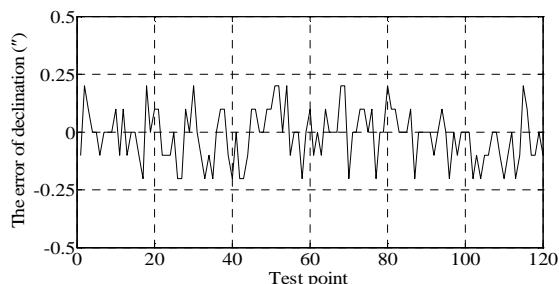

Fig. 7 The error curve of δ

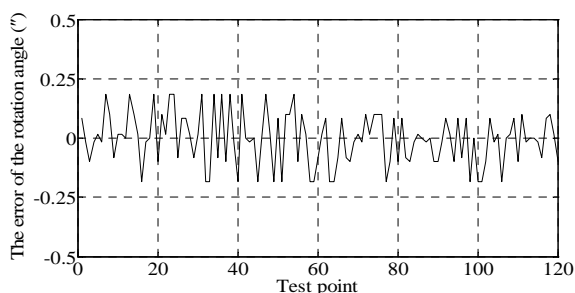

Fig. 8 The error curve of κ

Under the simulating condition of $0.1''$ σ value for the leveling and north-finder instruments, the error curves of the three attitude components show that the maximum error is just $0.25''$, which can fully meet with the need of state-of-the-art star sensor tests. The results of test simulations manifest that the method by precise timing to acquire the absolute reference attitude benchmark is feasible.

VIII. CONCLUSION

The method to construct the reference attitude benchmark is triggered by the requirement of outfield test of star sensor, and the equations to solve the final reference attitudes are put forward. Firstly, the whole steps are specified; Then, all the separate conversion matrixes of each loop are deduced, which include: the conversion matrix C_{wi} responsible for the transformation from the Earth Centered Inertial (ECI) frame i to the Earth-centered Earth-fixed (ECEF) frame w , which is calculated based on the time of an atomic clock, the conversion matrix C_{tw} from frame w to the geographic frame t , the matrix C_{pt} from frame t to the platform frame s , and the mounting matrix C_{sp} from frame p to the star sensor frame s , $C_{pi}=C_{pt}C_{tw}C_{wi}$, as the form of absolute reference attitude benchmark. After a star sensor is amounted on the platform, the mounting matrix C_{sp} must be added, so the reference attitudes matrix $C_{si}=C_{sp}C_{pt}C_{tw}C_{wi}$, the absolute reference attitude angles are calculated from the matrix C_{si} for the need of star sensor outfield tests. Finally, the computer program is finished to output the reference attitudes, comparing with which the error curves are drawn about the three axis attitude angles, and the absolute maximum error is $0.25''$. The analysis on each loop and the final simulating results manifest that the method by precise timing to acquire the absolute reference attitudes is feasible for star sensor outfield tests.

REFERENCES

- [1] Sun Changku, "Distortion Correction Method of Camera Lens Based on Affine Transformation and Perspective Projection," *Journal of Southwest University of Science and Technology*, vol. 25, no. 3, pp. 76–81, Sep 2010.
- [2] Huang Dingfa, "Distortion Correction Method of Camera Lens Based on Affine Transformation and Perspective Projection," *Journal of Southwest University of Science and Technology*, vol. 25, no. 3, pp. 76–81, Sep 2010.
- [3] Tian Hong, "Analysis for the Ground Observing Data of Star Sensor," *Opto-electronic Engineering*, vol. 28, no. 5, pp. 1–4, Oct 2011.
- [4] Fang Jiancheng, *The principle and application of celestial navigation*. Beijing, CN: Beijing University of Aeronautics and Astronautics Press, 2006, PP. 270-306.
- [5] Hirt C. and Bürki, B., "The Digital Zenith Camera - A New High-Precision and Economic Astrogeodetic Observation System for Real-Time Measurement of Deflections of the Vertical," in *Proceed. 3rd Meeting International Gravity and Geoid Commission of the International Association of Geodesy, Thessaloniki, Ziti, 2002*, PP. 161-166.
- [6] Tan Hao, "Coordinates Transformation of GPS Positioning," *Control Technology of Tactical Missile*, no. 4, pp. 40–43, 2005.
- [7] Fu Sunzhong, "Coordinates Transformation of several common kinds of coordinate system," *Geomatics Technology and Equipment*, vol. 5, no. 3, pp. 30-31, 2003.
- [8] Yu Bo, *The inertial technology*. Beijing, CN: Beijing University of Aeronautics and Astronautics Press, 1994, PP. 34-35.
- [9] Wang Chen, "Unscented quaternion particle filter application in micro-satellite estimating attitude," *Journal of Beijing University of Aeronautics and Astronautics*, vol. 335, no. 5, pp. 553–556, May 2007.
- [10] Liu Chaoshan, "Three-axes Missile Attitude Based on Star Sensor," *Control technology of tactical missile*, vol. 3, pp. S180-S194, 2005.
- [11] P Kenneth Seidelmann and John H Seago, "time scales, their users, and leap seconds," *METROLOGIA*, vol.48, pp. S180-S194, 2011.
- [12] Dennis DM, "Astronomical Time," *Proceedings of the IEEE*, vol. 79, no. 7, pp. 915-920, 1991.
- [13] ZiJinShan Observatory, *Medium astronomical calendar*. Beijing, CN: Science Press, 2011, PP. 22-29.