

Increase in Solar Thermal Energy Storage by using a Hybrid Energy Storage System

Hassan Zohoor, Zaeem M. Moosavi

Abstract—The intermittent nature of solar energy and the energy requirements of buildings necessitate the storage of thermal energy. In this paper a hybrid system of storing solar energy has been analyzed. Adding a LHS medium to a commercial solar water heater, the required energy for heating a small room was obtained in addition to preparing hot water. In other words, the suggested hybrid storage system consists of two tanks: a water tank as a SHS medium; and a paraffin tank as a LHS medium. A computing program was used to find the optimized time schedule of charging the storage tanks during each day, according to the solar radiation conditions. The results show that the use of such system can improve the capability of energy gathering comparing to the individual water storage tank during the cold months of the year. Of course, because of the solar radiation angles and shorten daylight in December & January, the performance will be the same as the simple solar water heaters (in the northern hemisphere). But the extra energy stored in November, February, March & April, can be useful for heating a small room for 3 hours during the cold days.

Keywords—Hybrid, Optimization, Solar thermal energy, Storage.

I. INTRODUCTION

THE intermittent nature of solar energy and the energy requirements of buildings necessitate the storage of thermal energy. Most solar energy storage systems use sensible heat storage (SHS), though using latent heat storage (LHS) systems have been considered too. There are many types of SHS for different applications [1]. Water or stones usually are used in low temperature solar energy systems. In some technologies thermal storage in sand bed with working fluid of air has been used. Concrete is a suitable medium for heat storage in passive solar energy houses. It has been used in intermediate temperature solar power plants too. The application of oil and stones has been tested in some solar power plants successfully. On the other hand, there are some phase change materials (PCM's) used in LHS systems, such as paraffin and salt hydrates. At last, reversible chemical reactions are the subject of recent studies for thermal energy storage.

Manuscript received June 30, 2008. This work was supported in part by the Iranian Fuel Conservation Organization.

H. Zohoor is fellow of the Academy of Sciences of IR Iran; professor & member of Center of Excellence in Design, Robotics & Automation, Sharif University of Technology, Tehran, Iran (e-mail: zohoor@sharif.edu).

Z. M. Moosavi is with faculty of Environment & Energy, Sciences & Researches Branch, Islamic Azad University, Tehran, Iran (phone: 98-912-3015009; fax: 98-21-22721716; e-mail: szaeemm@yahoo.com).

Despite good variety of thermal energy storage methods, an optimum economical point is not agreed. The development of remote, renewable-based energy is hindered in part by the lack of affordable energy storage. Requiring power-on-demand from an energy system powered by intermittent or seasonal sources may necessitate energy storage - an expensive proposition using conventional storage technologies. If multiple energy storage devices with complementary performance characteristics are used together, the resulting 'hybrid energy-storage system' can dramatically reduce the cost of energy storage over single storage systems. The coupling of more than one conventional thermal storage medium with each other provides one such hybrid system [2].

There is a large variety of studies on solar energy storage systems, which can not be mentioned in a short paper. Therefore, some recent studies about the subject are summarized below. Joudi & Abdul-Ghafour [3] developed software for simulation of hot water storage in a solar cooling system. Badescu, & Staicovici [4] studied the active heating system of a passive house, which included a water storage tank. Dharuman, *et al.* [5] described the design, construction and performance test results of solar water-heating device with its storage tank. LeBreux, *et al.* [6] modeled storage of sensible heat from solar energy in building concrete walls. Fraisse, *et al.* [7] studied a wall with an integrated solar air collector and a heavy ventilated internal wall, used to store solar energy. Simulation and analysis of phase change materials in different shapes and compositions as thermal energy storage mediums are considered by some researchers (Fang & Zhang [8], Benmansour *et al.* [9], Shaikh & Lafdi [10]). Researches about chargeable solar batteries are summarized by Nagai & Segawa [11].

Hybrid energy storage systems using more than one medium for complementary performance have been the subject of some other researchs. Model of a solar powered, battery-hydrogen hybrid energy storage system was developed by Vosen & Keller [2]. Parker & Clapper [12] have developed and patented such an innovative energy storage system, too. Hammou & Lacroix [13] have considered a hybrid thermal energy storage system (HTESS), using phase change materials, for managing simultaneously the storage of heat from solar and electric energy. Zohoor & Moosavi [14] discussed a method for finding the optimum performance state to increase the storage capability of a solar hybrid energy storage system.

II. DESCRIPTION OF THE SYSTEM

In Hybrid Energy Storage Systems (HESS), there are several media for storage. The HESS designed in this research includes a water tank and a paraffin tank. Some advantages of such a system have been explained in [14].

Solar energy is absorbed through two thermal collectors (The area of each collector is 2 m²). The working fluid running in solar collectors is a mixture of water and antifreeze (50 % each). The working fluid moves in the pipes of the collectors and tanks so that heat is stored in storage tanks. The minor pipes and their control valves enable us to choose the tank in which the working fluid is supposed to run based on the control system switching (Fig. 1). A circulating pump installed at the outlet of collectors, circulates the working fluid in the system with the flow rate of 0.04 kg/s. Other pipelines are also included in the system. These pipes direct the working fluid toward the end user, during the heat recovery hours. The end user is a radiator with eight fins which transfers the heat to a room with the area of 4.2 m². The room is a section of an office in the north of Tehran (35° N). The altitude of north Tehran is 1548 m above the sea level, and the temperature of the region can be derived from the statistics of Iran Meteorological Organization. The system functions in a way that throughout the day the solar energy is stored and it is recovered for heating a room or supplying the hot water which is to be consumed. Therefore, heat recovery begins after the decrease of the sun radiation.

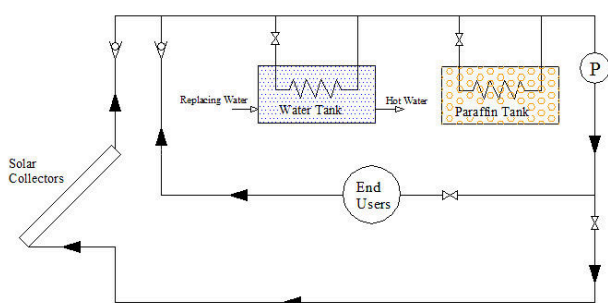

Fig. 1 Schematic of the solar hybrid storage system

III. INPUT DATA

Regarding the changing position of the sun, the variations in the length of the day and temperature of water and air in different seasons, the analysis and optimization should be done separately for each day of the year. In other words, optimization response in different days would be different. In this research, the optimization of storage during the six cold months of a year has been considered (January, February, March, April, November & December).

One of the input data is the temperature of the working fluid at the outlet of solar collectors. The working fluid temperatures relate to useful sun radiation hours beginning at 8:30 am and ending at 16:30 pm (considering each days of the former six month). The summarized values of this parameter are presented in Table (I).

The other input data is energy consumption rate at the time of the tank discharge. This rate is actually related to the heat load of the space under consideration in different hours depending on a variety of parameters such as geographical condition, area of the room, construction materials and the outdoor temperature. As mentioned earlier, the space under consideration is a small office (4.2 m²) in the north of Tehran: break walls, 10-20 cm thick, barrel vault about 30 cm thick (Including finishing touches), wood entrance door (2.5 m²), and windows with metal frame (1.1 m²). Table (II) shows the mean hourly outdoor temperature during the specified months.

The physical properties of water and antifreeze are available in the format of tables in many reference books [15]. Paraffin properties are given in Table (III).

IV. HEAT TRANSFER ANALYSIS

To obtain the amounts of the stored heat and recoverable heat, the analysis of heat transfer is necessary. In the assumed system of this problem, the amount of the total stored energy equals the sum of the stored energy in water and paraffin tanks:

TABLE I

AVERAGE TEMPERATURE OF WORKING FLUID AT THE OUTLET OF SOLAR COLLECTORS IN TEHRAN (°C)

Month	Hour	9:00am	10:00 am	11:00 am	12:00 pm	13:00 pm	14:00 pm	15:00 pm	16:00 pm	Max.
January		-	28.8	33.2	37	38.6	40.6	37.5	-	42.6
February		-	29.3	36.2	41.6	46.4	48.5	52.0	47.1	55.4
March		31.6	38.8	47.8	55.1	61.4	69.0	64.1	62.3	73.8
April		36.4	44.7	55.1	63.5	70.7	73.9	76.6	74.4	93.0
November		27.5	33.9	39	43.5	45.4	50.0	44.1	-	54.7
December		21.7	26.7	30.7	34.3	37.5	35.8	34.8	-	39.1

TABLE II

MEAN HOURLY OUTDOOR TEMPERATURE VARIATION OF TEHRAN DURING THE SIX COLD MONTHS (°C)

Month	Hour	0:00 am	03:00 am	06:00 am	09:00 pm	12:00 pm	15:00 pm	18:00 pm	21:00 pm	Mean Daily
January		3.5	2.6	2.2	4	6.8	7.6	5.6	4.4	4.6
February		3.6	2.7	2.3	4.2	6.3	6.9	5.3	4.2	4.4
March		10.9	9.9	9.3	12.6	14.9	16.3	14.6	12.5	12.6
April		17.2	15.5	14.9	18.9	21.5	22.5	21	18.7	18.8
November		9.6	9.2	8.9	12.4	13.9	14.5	11.8	10.5	11.4
December		7.7	7.3	6.7	9.5	12.2	12.9	10.0	8.6	9.4

TABLE III
PARAFFIN PHYSICAL PROPERTIES

Physical Property	Quantity
Melting Temperature (°C)	46.7
Density (kg/m ³)	786
Thermal Conductivity (W.(m.K) ⁻¹)	0.5
Specific heat Capacity (J.(kg.K) ⁻¹)	2890
Latent heat (kJ/kg)	209

$$E_{in} = Q_{win} + Q_{pin} \quad (1)$$

Where, Q_{win} and Q_{pin} are the stored energy in the water and paraffin tanks respectively. Similarly, the amount of total output energy equals the sum of recoverable energy of the water and paraffin tanks:

$$E_{out} = Q_{wout} + Q_{pout} \quad (2)$$

Where, Q_{wout} and Q_{pout} are respectably recoverable energy of water and paraffin tanks. In each day, energy storage begins at 8:30 am and ends at 16:30 pm, when there is almost no useful sun radiation. Recovery time of heat energy starts at 16:30 pm and ends at 8:30 am of the following day. Of course the stored energy is not sufficient for the whole time cycle.

The performance analysis of each tank during charge and discharge periods is an unsteady heat transfer problem. The temperature of the contents of the tanks during charging and discharging is variable. Hence, the amount of the input or output energy of the tank at the moment t in an unsteady process is calculated by the following equation [15]:

$$Q = - \int \rho c [T(r, t) - T_i] dV \quad (3)$$

Where ρ stands for density of the material that stores heat, c is specific heat capacity, $T(r, t)$ is temperature distribution function in the storing medium, T_i is the initial tank temperature and V is the volume of the storage material. The dimensionless shape of the above equation is in the form of the following series of relations [15]:

$$\begin{aligned} \frac{Q}{Q_0} &= \frac{1}{V} \int (1 - \theta^*) dV \\ \theta^* &= \frac{T - T_\infty}{T_i - T_\infty} \\ Q_0 &= \rho c V (T_i - T_\infty) \end{aligned} \quad (4)$$

Where, T_∞ is the working fluid temperature. T_∞ at the charging periods of the tanks is the working fluid temperature at the outlet of solar collectors while considering negligence temperature drop. Yet, at the times of tank discharge, T_∞ is the minimum temperature of the working fluid for creating desired heat at the room.

The water storage tank in this research is exactly similar to 250 liters tanks use in common solar water heaters. These tanks generally have cylindrical shape with the diameter of 50 cm and length of 130 cm. The working fluid runs in the external case of these tanks and transfers heat to the internal case. The paraffin storage tank is a box with these dimensions: 52 cm × 52 cm × 71.5 cm. There are 704 spherical capsules containing paraffin inside the tank. The working fluid passes through these capsules and transfers the heat to paraffin or it absorbs heat from paraffin. The idea of making the paraffin storage tank like this has been derived from [13].

Heisler [16] shows that one can solve the integral of (4) for a cylinder (Water tank) and a sphere (Paraffin capsules) respectively as (5) and (6).

$$\frac{Q}{Q_0} = 1 - \frac{2\theta_0^*}{\xi_1} J_1(\xi_1) \quad (5)$$

$$\frac{Q}{Q_0} = 1 - \frac{3\theta_0^*}{\xi_1^3} [\sin(\xi_1) - \xi_1 \cos(\xi_1)] \quad (6)$$

where $\theta_0^* = C_1 \cdot \exp(-\xi_1^2 \cdot F_0)$, ξ_1 is the positive root of equation $\xi_1 \cdot \tan(\xi_1) = Bi$ and C_1 is a coefficient in terms of Biot number (Bi) which appears as a table in reference books [15]. J_1 is also Bessel Function and F_0 is Fourier number. It is worth mentioning that for the calculation of Bi and for including the effect of free convection of the fluid that is in the tanks, an effective conductivity coefficient has been considered by the use of the equation devised by Raithby & Hollands [17].

On the other hand, for calculating the tanks' temperature at the initial stage of charging (or discharging) process, the temperature of the tanks must be calculated at the end of the last charging (or discharging) interval. The tanks' temperature distribution at the end of the charging or discharging interval for a cylinder (Water tank) and a sphere (Paraffin tank) is calculated by these equations respectively:

$$\frac{T - T_\infty}{T_i - T_\infty} = \theta_0^* \cdot J_0(\xi_1 r^*) \quad (7)$$

$$\frac{T - T_\infty}{T_i - T_\infty} = \theta_0^* \frac{1}{\xi_1 r^*} \sin(\xi_1 r^*) \quad (8)$$

Where $r^* = r/r_0$ is the dimensionless radius, T is the temperature at each point and J_0 is the Bessel Function.

Since the outlet temperature of the collectors varies during the day hours, the value of T_∞ is not constant during the charging process. In the same way, at the time of discharge and with respect to the variation of the outdoor temperature, the space heat load is variable. Therefore, T_∞ is never constant during the course of time, and the solution of the problem is a little bit complicated. With respect to the complexity and parametrical nature of the problem, six separate computer programs have been devised:

- 1- Program for calculating storable energy in the water tank in terms of solar collectors' outlet temperature.
- 2- Program for calculating storable energy in the Paraffin tank in terms of solar collectors' outlet temperature.
- 3- Program for calculating heat load of the assumed space in terms of outdoor temperature.
- 4- Program for calculating the amount of recoverable energy from the water tank in terms of heat load of the space.
- 5- Program for calculating the amount of recoverable energy from the paraffin tank in terms of heat load of the space.
- 6- Program to correlate the above programs and calculate the total energy stored in each tank and total energy recovered from each tank during the time period.

These six computer programs are developed by MATLAB 7 and linked to each other so that to enable us to obtain the stored/recovered energy in a period. The assumed period in this research is 181 days, started on November 1, 2006, ended on April 30, 2007.

The tanks temperature in the early morning is considered as the main input for Programs 1 & 2. Besides, the outlet temperature of the solar collectors in terms of time is taken as the second input for these Programs. By using mentioned input data and refer to (5)-(8), Programs 1 & 2 calculate the temperature of tanks and stored energy after an hour, as the result of the first hour interval. This calculated temperature in itself is taken as the input temperature for the second hour. Moreover, the outlet temperature of collectors in the second hour is used again. Similarly, calculations will continue. At the end of the day, when the outlet temperature of collectors is lower than that of the tanks, calculations will stop in Programs 1 and 2, and the amounts of the stored heat in each hour are added together. Therefore, the total stored energy of the whole day will be obtained. The practical procedure and relation among these Programs are so developed as to enable them to store energy only in one of the tanks or in general, calculations of storage are consecutive. The terminal temperature of each storage tank at the end of sun radiation (the end of the storage process) will be used as the initial temperatures of tanks in energy recovering process. Programs 4 and 5 can calculate the recoverable energy and the amount of the temperature drop of each tank in the same way in each hour interval. After consumption of the stored energy, the values of the recovered energy are added together. Here, instead of the outlet temperature of collectors, the other input of these Programs is the heat load of the space. While the amount of the recoverable energy is sufficient for the heat load, energy recovering will continue, otherwise the calculations of the recovering process will stop.

The explained procedure was generalized to each of 181 days of the assumed period. Finally, the values of daily stored energy and daily recovered energy are added together for obtaining the summarized results.

V. OPTIMIZATION

Flexibility in choosing the best available storage medium on the basis of the solar collectors' outlet temperature will increase the charging chance during the day. The main objective of the research is the efficiency optimization of a solar hybrid energy storage system. On this basis, we had to find the optimized state of the system performance. Since the system has two storage tanks, there would be two choices for energy storage: water tank or paraffin tank. This attends some other problems: How long each tank should be charged and what will be the sequence of charging them? Similar points are considerable in recovering process too. We name these answers "time schedule". Because of different solar radiation and weather condition, the schedule will vary from day to day. In other words, after optimization process, it might be obtained 181 different storage time schedules for every 181 days of the assumed period. For example, the optimized storage time schedule has been obtained with respect to the conditions of March 26, 2007 in [14].

Considering (2) to (8), in order to recovering maximum solar energy during each day, we can write the Objective Function of the problem as below:

$$\text{Max } E_{out} = Q_{wout} + Q_{pout} \quad (9)$$

In this research, for finding each day's optimum time schedules, a numerical computer program was developed. The algorithm is a sweeping method that checks all of the imaginable storage time schedules in a hybrid storage system. Comparing the values of recovered energy at the end of each day, the maximum value can be found. So, the respective time schedule will be extracted.

As mentioned before, we have to choose one of the available tanks for storing/recovering energy at each hour to gain the maximum storage capacity. So, it is obvious that there are too many available time schedules that can be supposed for each day. For example, assuming daily eight hours storage duration, there will be $2^8 (=256)$ different storage time schedules available for each day. Considering the energy recovering hours, total number of time schedules will be 2^{24} for each day. Of course, because of the limited amount of stored solar energy in one day, the recovered energy will not be sufficient for the whole 24 hours of a day. Therefore, we use a check point in the optimizer program to decrease the number of available time schedules proportional to the real amount of stored energy in each day. With this method, the required time for optimizing will decrease too much.

On the basis of energy storage in one of the tanks and energy recovery from one of them, the optimized solutions can only be 0 or 1. So, the optimization problem would be an integer programming. For example, if at 11 o'clock of November 30, storage in the water tank occurs, the storage time schedule, $sts(30,11)=1$, otherwise $sts(30,11)=0$. Similarly, 1 and 0 will be allocated to the recovery time schedule, rts .

VI. RESULTS COMPARISON

The results of [14] showed that using such a hybrid system, the growth of 10% in storage efficiency is accessible. But this result was attained with respect to the conditions of a particular day (March 26, 2007). It will be studied in this paper whether the result can be generalized to the whole assumed period?

As mentioned in previous section, the optimization process was done for each of 181 days in cold months. Optimized points were found and the maximum energy recovery for each day was calculated separately. But it is not possible to write all of 181 values in this paper. So, we decided to prepare a summarized table, based on the cumulative results of every month. Table (IV) shows the maximum stored energy in the hybrid storage system at the optimized point. Respectively, table (V) represents the maximum recoverable energy during the assumed period.

TABLE IV
MAXIMUM STORED ENERGY IN HYBRID STORAGE SYSTEM (MJ)

Month	Stored Energy in Water Tank	Stored Energy in Paraffin Tank	Total stored Energy
Nov-2006	23.1	16.6	39.7
Dec-2006	≈ 0	≈ 0	≈ 0
Jan-2007	0.3	≈ 0	0.3
Feb-2007	34.1	26.1	60.2
Mar-2007	70.6	206.2	276.8
Apr-2007	174.5	388.9	563.4
Sum	302.6	637.8	940.4

TABLE V
MAXIMUM RECOVERED ENERGY FROM HYBRID STORAGE SYSTEM (MJ)

Month	Recovered Energy from Water Tank	Recovered Energy from Paraffin Tank	Total Recovered Energy
Nov-2006	21.3	12.6	33.9
Dec-2006	≈ 0	≈ 0	≈ 0
Jan-2007	0.2	≈ 0	0.2
Feb-2007	31.0	23.2	54.2
Mar-2007	63.9	182.8	246.7
Apr-2007	158.0	395.3	553.3
Sum	274.4	613.9	888.3

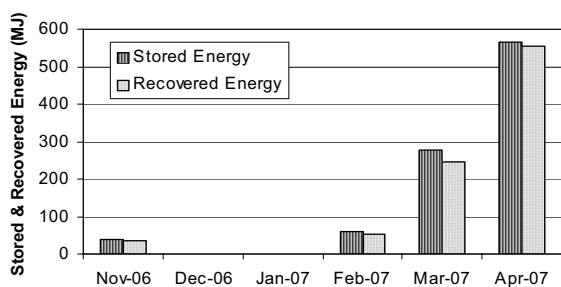

Fig. 2 stored energy & recovered energy values, hybrid storage system

Now, we should consider that how much this hybrid system has increased the storage capability. In the next tables, the results will be compared with the situation when only the water tank is used (Table VI & VII). The system was adopted

for heating the small introduced room up to 22.8 °C and preparing 42 °C domestic hot water. According to the results, this hybrid storage system will increase the heating duration of the assumed small room and prepare more hot water (Table VIII).

TABLE VI
COMPARISON OF OPTIMIZED HYBRID SYSTEM & SINGLE WATER TANK (STORAGE)

Month	Stored Energy in Hybrid System (MJ)	Stored Energy in Single Water Tank (MJ)	Increase (%)
Nov-2006	39.7	31.7	25.2
Dec-2006	≈ 0	≈ 0	-
Jan-2007	0.3	0.3	-
Feb-2007	60.2	48.0	25.4
Mar-2007	276.8	186.3	48.6
Apr-2007	563.4	347.8	62.0
Sum	940.4	614.1	53.1

TABLE VII
COMPARISON OF OPTIMIZED HYBRID SYSTEM & SINGLE WATER TANK (RECOVERY)

Month	Recovered Energy from Hybrid System (MJ)	Recovered Energy from Single Water Tank (MJ)	Increase (%)
Nov-2006	33.9	28.7	18.1
Dec-2006	≈ 0	≈ 0	-
Jan-2007	0.2	0.2	-
Feb-2007	54.2	43.4	24.9
Mar-2007	246.7	168.6	46.3
Apr-2007	553.3	314.7	75.8
Sum	888.3	555.6	59.9

TABLE VIII
COMPARISON OF OPTIMIZED HYBRID SYSTEM & SINGLE WATER TANK (HEATING DURATION & HOT WATER PREPARING)

Month	Hybrid Storage System		Single Water Tank	
	Heating Duration (hr)	Hot Water Supply (lit)	Heating Duration (hr)	Hot Water Supply (lit)
Nov-2006	13	133	-	216
Dec-2006	0	0	-	0
Jan-2007	0	2	-	2
Feb-2007	13	234	-	328
Mar-2007	120	483	-	1273
Apr-2007	330	1192	-	2374
Sum	476	2044	-	4193

VII. CONCLUSION

In this research a hybrid system of storing solar energy was analyzed. It is shown that the use of such systems can result in better efficiency than individual storage systems. The introduced system includes two tanks (water and paraffin) with the flexibility in choosing the best storage medium on the basis of the solar collectors' outlet temperature. Comparing with an individual water tank, the hybrid storage system gathers 53.1% more solar energy at the optimized point. Respectively, the energy recovery from the hybrid system increases 59.9%.

The system is so designed as to enable it to make the required energy for heating and preparing the hot water

consumption. Here are some reasons concerning the improvement of efficiency:

- The charging chance during the day will increase; because there is a lower temperature medium when the sun radiation falls gradually.
- The heat loss will decrease because a portion of energy will store in a lower temperature medium.
- As a result of the distribution of energy in different temperature media, the exergetic efficiency will increase.
- The optimum designing with consideration to mass and volume will be accessible.

This flexible storage system can be considered an intelligent storage system. This research is the first step toward the realization of the use of the solar hybrid storage systems in buildings. Some steps that must be taken in the future for the completion of this research are as follows:

- Economic study and optimization of the efficiency and cost.
- Optimization of the shape, size and arrangements of the tanks.

REFERENCES

- [1] Dincer, I., "On thermal energy storage systems and applications in buildings", *Energy and Buildings*, Volume 34, Issue 4, May 2002, Pages 377-388.
- [2] Vosen, S.R., and Keller, J.O., "Hybrid energy storage systems for stand-alone electric power systems: optimization of system performance and cost through control strategies", *International Journal of Hydrogen Energy*, Volume 24, Issue 12, December 1999, Pages 1139-1156.
- [3] Joudi, Kh.A., and Abdul-Ghafour, Q.J., "Development of design charts for solar cooling systems. Part I: computer simulation for a solar cooling system and development of solar cooling design charts", *Energy Conversion and Management*, Volume 44, Issue 2, January 2003, Pages 313-339.
- [4] Badescu, V., and Staicovici, M.D., "Renewable energy for passive house heating - Model of the active solar heating system", *Energy and Buildings*, Volume 38, Issue 2, February 2006, Pages 129-141.
- [5] Dharuman, C., Arakeri, J.H., and Srinivasan, K., "Performance evaluation of an integrated solar water heater as an option for building energy conservation", *Energy and Buildings*, Volume 38, Issue 3, March 2006, Pages 214-219.
- [6] LeBreux, M., Lacroix, M., and Lachiver, G., "Fuzzy and feedforward control of an hybrid thermal energy storage system", *Energy and Buildings*, Volume 38, Issue 10, October 2006, Pages 1149-1155.
- [7] Fraisse, G., Johannes, K., Trillat-Berdal, V., and Achard, G., "The use of a heavy internal wall with a ventilated air gap to store solar energy and improve summer comfort in timber frame houses", *Energy and Buildings*, Volume 38, Issue 4, April 2006, Pages 293-302.
- [8] Fang, X., and Zhang, Zh., "A novel montmorillonite-based composite phase change material and its applications in thermal storage building materials", *Energy and Buildings*, Volume 38, Issue 4, April 2006, Pages 377-380.
- [9] Benmansour, A., Hamdan, M.A., and Bengueuddach, A., "Experimental and numerical investigation of solid particles thermal energy storage unit", *Applied Thermal Engineering*, Volume 26, Issues 5-6, April 2006, Pages 513-518.
- [10] Shaikh, Sh., and Lafdi, Kh., "Effect of multiple phase change materials (PCMs) slab configurations on thermal energy storage", *Energy Conversion and Management*, Volume 47, Issues 15-16, September 2006, Pages 2103-2117.
- [11] Nagai, H., and Segawa, H., "Energy-storable dye-sensitized solar cell with a polypyrrole electrode", *Chem Commun (Camb)*, 2004 Apr 21, Pages 974-5.
- [12] Parker, R., and Clapper, Jr.W.L., "HYDROGEN-BASED UTILITY ENERGY STORAGE", *Proceedings of the DOE Hydrogen Program Review*, NREL/CP-570-30535, 2001.
- [13] Hammou, Z.A., and Lacroix, M., "A hybrid thermal energy storage system for managing simultaneously solar and electric energy", *Energy Conversion and Management*, Volume 47, Issue 3, February 2006, Pages 273-288.
- [14] Zohoor, H., & Moosavi Z.M., "Efficiency Optimization in Solar Hybrid Energy Storage Systems", *Proceeding of the 15th ISME 2008 Conference*, Bhopal, India, March 2008, Pages 212-223.
- [15] Incropra, F.P., and Dewitt, D.P., *Introduction to Heat Transfer*, Library of Congress Cataloging in Publication Data, 2nd Edition, 1990.
- [16] Heisler, M.P., "Temperature Charts for Induction and Constant Temperature Heating", *Trans. ASME*, 69, 1947, Pages 227-236.
- [17] Raithby, G.d., & Hollands K.G.T., "A General Method of Obtaining Approximate Solutions to Laminar and turbulent Free Convection Problems", *Advances in Heat Transfer*, Vol. 11, 1975, Pages 265-315.