

Comparative Evaluation of Adaptive and Conventional Distance Relay for Parallel Transmission Line with Mutual Coupling

S.G. Srivani, Chandrasekhar Reddy Atla, K.P.Vittal

Abstract—This paper presents the development of adaptive distance relay for protection of parallel transmission line with mutual coupling. The proposed adaptive relay, automatically adjusts its operation based on the acquisition of the data from distance relay of adjacent line and status of adjacent line from line circuit breaker IED (Intelligent Electronic Device). The zero sequence current of the adjacent parallel transmission line is used to compute zero sequence current ratio and the mutual coupling effect is fully compensated. The relay adapts to changing circumstances, like failure in communication from other relays and non - availability of adjacent transmission line. The performance of the proposed adaptive relay is tested using steady state and dynamic test procedures. The fault transients are obtained by simulating a realistic parallel transmission line system with mutual coupling effect in PSCAD. The evaluation test results show the efficacy of adaptive distance relay over the conventional distance relay.

Keywords—Adaptive relaying, distance measurement, mutual coupling, quadrilateral trip characteristic, zones of protection.

I. INTRODUCTION

THE constraints in obtaining new right of ways have led to a number of parallel lines, as well as multi-terminal lines.

In transmission systems throughout the world, it is common to find double circuit towers transmitting power in narrow physical corridors. There are also the places in power systems where single circuit towers are run in parallel in wide corridors. This trend will increase due to continuing growth of load centers.

Distance protection is a commonly preferred over other line protection schemes. Its operation can rely only upon the local measurement and it is easy to extend functionality of a pilot type protection by the use of communication links. It can easily provide a staged remote backup protection for adjacent lines. However, when applied to parallel lines, the performance of conventional distance relays is adversely

affected by the mutual coupling effects between the parallel lines, which vary with the line operating condition and bus configuration. Therefore, relays must be configured to avoid overreach / under reach operation under the worst-case scenarios. This results in sub optimal performance of a relay under other operating conditions.

Several researchers have proposed solutions to enhance the performance of the distance relay [1]-[4]. An adaptive distance scheme was suggested in [1], in which a correction factor, based on the information of the surrounding system of the protected line under different operating status, was used in the impedance calculation. In [2], an adaptive distance protection scheme is proposed which accesses multiple locally available signals and automatically adapts its operation to the signal availability. A traveling-wave based parallel line protection scheme was investigated in [3]. In [4], the phase current comparison between two circuits and positive sequence current level detection were used in conjunction with parallel line's zero sequence current compensated impedance calculation. In [5], loadability of transmission lines is discussed extensively, and useful in simulation of fault conditions.

The implementation of adaptive distance relaying scheme to compensate mutual coupling effect and its elaborate evaluation procedure is not reported in the published literature. This paper presents the development of adaptive distance relay for protection of parallel transmission line with mutual coupling. The proposed adaptive relay automatically adjusts its operation based on the acquisition of data from distance relay of adjacent line and status of adjacent line from line breaker IED. When data from the adjacent line relay are available, zero sequence current of the adjacent parallel transmission line is used to compute zero sequence current ratio and the mutual coupling effect is fully compensated. On the other hand, the conventional distance relay would cause false tripping of healthy lines, due to undesirable compensation incorporated in relay logic program of distance relay of the adjacent healthy line. When the parallel line's zero sequence current is not available from its communication channel, the adaptive distance relay uses line operating status to select the appropriate zero sequence current compensation factor in impedance calculation. Under severe circumstances, when line status as well as signal data are not available, the adaptive relay uses default compensation factor as minimum mode operation. The sections that follow explain the operating

Manuscript received June 27, 2008.

S.G.Srivani is with the National Institute of Technology Surathkal, Karnataka, India. 080-23383976, 9844327829,(e-mail:abc_sgs@yahoo.com.)

Chandrasekhar Reddy Atla is with the National Institute of Technology, Surathkal, Karnataka, India (e-mail: sekhar_311@yahoo.com)

K.P.Vittal is with the National Institute of Technology, Surathkal, Karnataka, India (vittal_nitk@yahoo.com)

principle of the proposed adaptive relaying scheme and evaluation of its performance using steady state and dynamic test procedures.

II. DISTANCE PROTECTION OF A DOUBLE-CIRCUIT LINE WITH MUTUAL COUPLING

The mutual coupling effect between lines, which varies with the line operating conditions and fault conditions is the main problem faced by conventional distance relays in distance measurement when applied on the parallel lines. The mutual coupling effects of zero sequence currents between parallel lines will be significant. Fig.1 illustrates the conventional distance as applied to protect the parallel lines with mutual coupling.

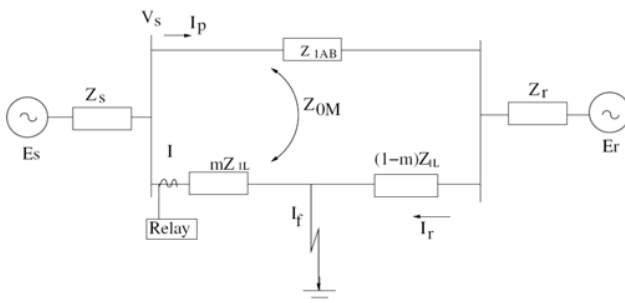

Fig. 1. Parallel Transmission Line.

For a line to ground fault on a single transmission line, the measured phase impedance seen by the conventional distance relay is given by using conventional zero sequence current compensation method.

The measured impedance in phase 'a' when the fault impedance is zero is,

$$Z_{m_a} = \frac{V_a}{I_a + K_0 I_0} = mZ_{1L} \quad (1)$$

$$K_0 = \frac{Z_{0L} - Z_{1L}}{Z_{1L}}$$

where K_0 is the line zero sequence current compensation factor; Z_{0L} and Z_{1L} are the zero and positive sequence impedance of the line; V_a and I_a are the post-fault phase voltage and current at the relay location, m is the per-unit distance between the relay and the fault location and I_0 is the post-fault zero sequence current at the relay location.

Generally, the mutual coupling effects between parallel lines caused by positive and negative sequence currents are very small and are considered to be negligible. However, the mutual coupling effects of zero sequence currents between parallel lines could be significant [2].

The post-fault voltage of phase at the relay location for a phase-a-to-ground fault when fault impedance is zero is given by

$$V_a = mZ_{1L}(I_a + K_0 I_0 + mZ_{0M} I_{0p}) \quad (2)$$

Where, Z_{0M} is the total zero sequence mutual coupling line impedance and I_{0p} is the parallel line's zero sequence current.

The measured fault impedance of a distance relay using conventional zero sequence current compensation will contain errors since

$$Z_{1m_a} = \frac{V_a}{I_a + K_0 I_0} = mZ_{1L} + \zeta Z_{1L} \quad (3)$$

Where, the per unit error ζ in terms of Z_{1L} is

$$\zeta = \frac{m(Z_{0M} / Z_{1L}) I_{0p}}{I_a + K_0 I_0} \quad (4)$$

This error may cause the relay either to overreach or underreach depending upon the relative direction of the parallel line's zero sequence current, I_{0p} , versus the compensated current, $I_a + K_0 I_0$. If they are in the opposite direction, the relay will overreach. If in the same direction, the relay will underreach.

The above overreach or underreach effect of conventional distance relays, caused by the mutual coupling may be compensated by selecting proper relay settings provided the bus configuration, system impedance and line operating condition of a parallel line do not change during the normal operation.

Due to various reasons like load dispatch, forced outage, scheduled maintenance etc, operating condition of a parallel line could change from one to the other during the normal operations. Fig. 2(a) and 2(b) show such two typical operating conditions of a double-circuit line.

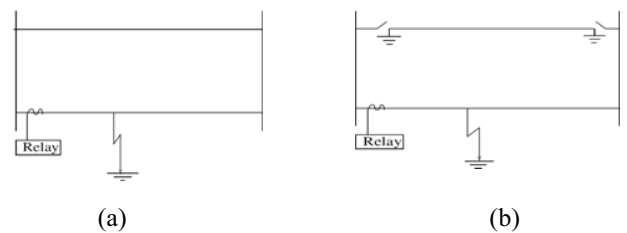

Fig. 2. Parallel-Line typical Operating Modes. (a). Both Lines are in Operation. (b). One Line switched off and Grounded at Both the Ends.

The mutual coupling effects on zone reach are different for these two operating conditions. Generally, the line operating condition shown in Fig. 2(a) will cause conventional distance relay to underreach and the line operating condition shown in Fig. 2(b) will cause conventional distance relay to overreach for remote end faults. There are other line operating conditions and/or the bus configurations combinations that could be encountered in the field, which further complicates the problem.

Note that a parallel line in most cases is operated under the operating condition in Fig. 2(a); reduced Zone 1 coverage

reduces the chance of fault isolation by Zone 1 relay from both ends of the protected line. The situation could become even worse when the impact of fault resistance is considered, which may under certain conditions to cause the protected line's middle section to lose the zone 1's coverage altogether. Prolonged fault clearing reduces the system stability level and may lead to severe stability problems under constrained system operating conditions. The common practice in parallel line distance protection is to select relay settings to avoid possible false operation under the worst-case scenario [2].

Hence to minimize the effect of incorrect settings the system calls for the Adaptive protection, which covers the wide range of power system condition thus increasing the accuracy and selectivity of the protection system.

III. DEVELOPMENT OF ADAPTIVE DISTANCE RELAY

The proposed adaptive relaying scheme on each protected line accesses the three-phase voltage and current signals of the protected line. In addition, the zero sequence current and line operating status of the paralleled lines at the substation where the distance relay is located will be used by the scheme. The parallel line's zero sequence current could be obtained either through additional cabling, direct communication link between relays, or substation local networks. The parallel line's operating status could be obtained by accessing the circuit breaker's auxiliary contacts and/or parallel line's voltage/current level detection or substation PLC (programmable logic controller). The scheme automatically adapts its operation based on the signal availability from the parallel lines to achieve an optimal performance by using the best available signals.

If the parallel line's zero sequence current is available the scheme uses it first to compensate the mutual coupling effect in impedance measurement on faulted line. For a phase-a -to-ground fault on the protected line, the correct fault impedance on the faulted line is:

$$Z_{m-a} = \frac{Va}{I_a + K_0 I_0 + k_{0M} I_{0p}} = mZ_{1L} \quad (5)$$

$$\text{Where } K_{0M} = \frac{Z_{0M}}{Z_{1L}},$$

The distance measurement on the faulted line will always be correct under any line operating condition and/or bus configuration, since errors in distance measurement caused by the mutual coupling effect of I_{0p} is fully compensated.

Normal 80% zone coverage for zone 1 thus can be used, which will provide consistent zone coverage under all conditions for parallel lines.

When Parallel line's zero sequence current compensation is applied on both faulted line and healthy line in the impedance computation, the relay placed in healthy line will also operate with the relay placed in faulted line. To avoid such possible false operation, the compensation should be adapted to the line fault status. In the proposed scheme it is achieved by using a zero sequence current ratio criterion.

The zero sequence current ratio for a protected line is

defined as a magnitude ratio of paralleled line's zero sequence current over the zero sequence current measured on the protected line [2].

For example, the zero sequence current ratio for the faulted line in the system in Fig. 1 is defined as (note that its inverse will define the zero sequence current ratio on the healthy line).

$$\alpha_0 = \frac{|I_{0p}|}{|I_0|} \quad (6)$$

By setting a proper threshold equal to 1.0 plus some margin so that the compensation will not be performed when the ratio on the protected line is above the threshold, the relay false operation on the healthy line for close-in faults on an adjacent parallel line could be effectively prevented [2].

when the parallel line's zero sequence current is not available due to local technical problems to the relay for various reasons, the proposed adaptive scheme adopts to use parallel line's operating status signal, for an improved performance. A relay could make proper zone setting and/or zero sequence compensation factor adjustment to take into account of the mutual coupling effect corresponding to each line operating status.

The sequence network in Fig. 3 corresponds to the line operating condition in Fig. 2(a).

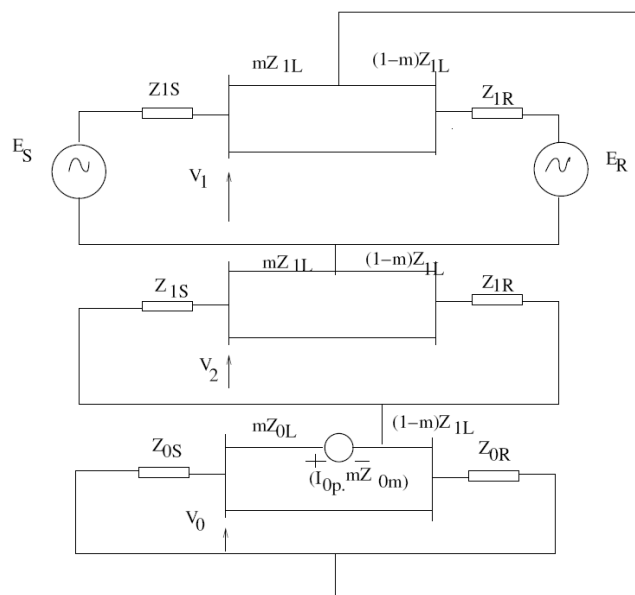

Fig. 3. Phase-To Ground Fault in One of Two Parallel Lines with Zero Sequence Mutual Coupling.

In Fig. 3, $Z_{AB0} = Z_{L0}$ is assumed, the accurate zero sequence compensation factor in (1) at m the fault location under this condition is,

$$K_1(m) = K_0 \left(1 + \frac{Z_{0M}}{Z_{0L} - Z_{1L}} \cdot \frac{mZ_{0R} - (1-m)Z_{0S}}{(2-m)Z_{R0} + (1-m)(Z_{0S} + Z_{0L} + Z_{0M})} \right) \quad (7)$$

This is a function of the fault location, system, and line impedance. Using k_0 with I_0 in the fault impedance

calculation will result in overestimate of fault distance for faults close to and beyond the remote end ($m = 1.0$) since

$$K_0 < |K_1(m = 1.0)| = \left| \frac{Z_{0L} - Z_{1L} + Z_{0M}}{Z_{1L}} \right| \quad (8)$$

The value for zone 1 could be determined at the zone setting boundary (80%) using (7) for more accurate compensation of the mutual coupling effect. It should be selected to also consider the system parameter variations (mainly system impedance variations) during system operation, plus certain margins to ensure that relay will not overreach under all these variations.

Similarly, the zero sequence current compensation factor for one parallel line switched off and grounded at both ends could be derived. The zero sequence network for one parallel line switched off and grounded at both ends is shown in Fig. 4.

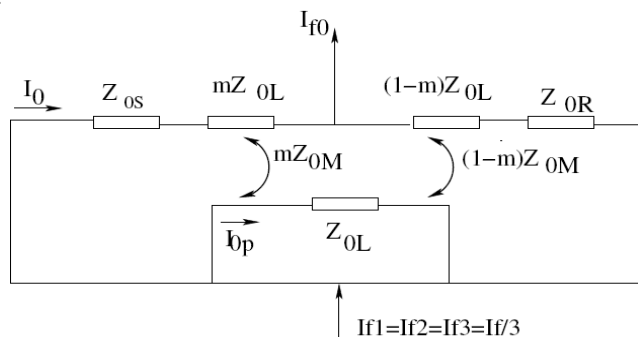

Fig. 4. Zero Sequence Network Connection for One Line Switched Off and Grounded Condition in A Single-to-Ground Fault

From Fig. 4, if $Z_{0L} = Z_{0,AB}$ is assumed, the accurate zero sequence compensation factor in (1) at the fault location m under this condition is given by

$$K_2(m) = K_0 \left\{ 1 + \frac{Z_{0M}}{Z_{0L} - Z_{1L}} \cdot \frac{Z_{0M}[(1-m)Z_{0S} - mZ_{0R}]}{Z_{0L}[(1-m)Z_{0L} + Z_{0R}] - (1-m)Z_{0M}^2} \right\} \quad (9)$$

And it is also a function of the fault location, system, and line impedance. From the above equation, using k_0 with I_0 in the fault impedance calculation will result in an underestimate for remote end faults ($m = 1.0$) since

$$|K_0| > |K_2(m = 1.0)| = \left| \frac{Z_{0L} - Z_{1L} - \left(\frac{Z_{0M}^2}{Z_{0L}} \right)}{Z_{1L}} \right| \quad (10)$$

The value for zone 1 should also be determined at the zone setting boundary (80%) using (9) for more accurate compensation of the mutual coupling effect taking into account of system parameter variations, plus certain margins to avoid overreach operations.

Though not as effective as using parallel line's zero sequence current, adapting zero sequence compensation factor to line operating status still achieves the performance

improvement by compensating main underreach and overreach effect under each line operating condition.

In the case that both parallel line's zero sequence current and line operating status signals are not accessible, a default zero sequence compensation factor (K_3), based on the worst-case scenario, will be used by the new adaptive relay to ensure a reliable operation of the relay. This operation mode achieves the same performance level as conventional distance relays operating on the parallel lines.

An exemplary flowchart illustrating how the new adaptive scheme works is shown in Fig. 5. In this flowchart, the adaptive scheme first ascertains whether the parallel line's zero sequence current is available. If available, the zero sequence current ratio is used to determine the line fault status. The parallel line's zero sequence current will be used for faulted line impedance computation, but will not be used in healthy line's impedance calculation.

When the adjacent parallel transmission line's current is not available, the parallel line's operating status at the relay location is used to select the proper zero sequence compensation factors. The relay logic program follows the sequence shown in flowchart, for both line in operation condition, and for one line switched off condition. In the case that both the parallel line's current and operating status are not accessible, the scheme uses the default zero sequence current compensation factor.

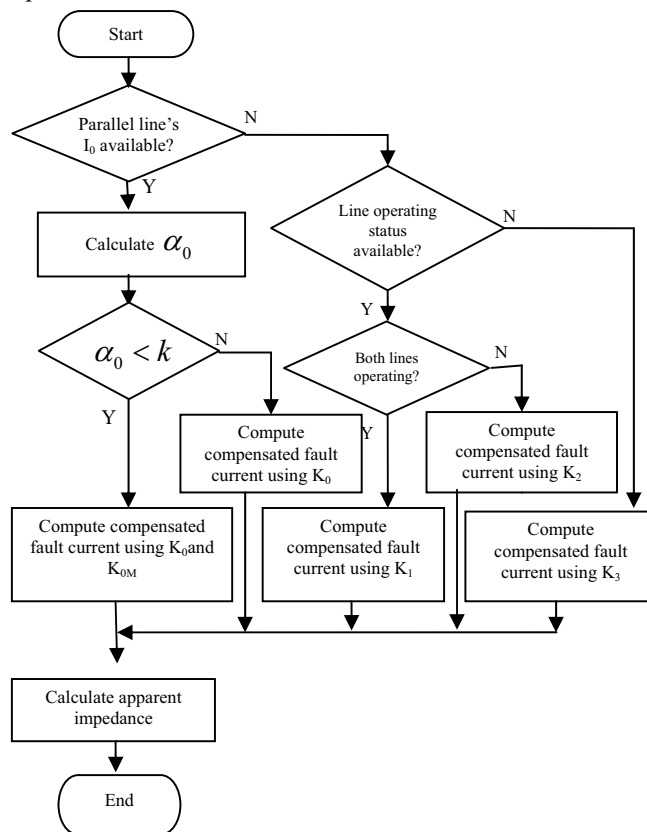

Fig.5. Adaptive Distance Protection logic Scheme Flow

IV. COMPARATIVE EVALUATION OF CONVENTIONAL AND ADAPTIVE DISTANCE RELAY BY DYNAMIC TEST

Comparing its performance with conventional distance relay carries out the evaluation of the simulated adaptive distance relay. For this purpose both relays are subjected to dynamic test.

The dynamic tests essentially determine the operating time and reach settings of the relay, when subjected to various fault conditions. This requires the simulation of transient fault dynamic conditions of the power transmission line. For this purpose EMTDC/PSCAD software package is used. The parallel transmission system considered is a 400KV, 200km long Transmission system as shown in Fig.6.

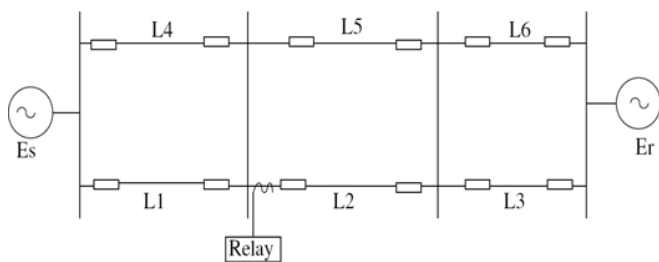

Fig. 6. Single Line Diagram of Parallel Transmission System.

The system parameters are as follows:

Line Impedance:

$$Z_{L0} = 0.297 + 1.1842i \Omega / km$$

$$Z_{L1} = Z_{L2} = 0.0352 + 0.4028i \Omega / km$$

$$Z_{0m} = 0.262 + 0.7814i \Omega / km$$

Equivalent System Impedance:

$$Z_{S0} = 23.459 + 108.31i \Omega$$

$$Z_{S1} = 8.561 + 20.241i \Omega$$

$$Z_{R0} = 17.53 + 70.795i \Omega$$

$$Z_{R1} = 8.36 + 15.57i \Omega$$

In this development, frequency dependent (Phase) model is selected in EMTDC/PSCAD for transmission line model. The adaptive relay is developed for zone 1 protection as shown in Fig. 7. Zone1 covers the 80% of the line L2. The quadrilateral trip characteristic will change automatically obtaining the parallel line's operating status through substation PLC

In order to conduct the evaluation test, two configurations of parallel transmission line are considered, they are

- 1) One Line is Switched Off and grounded at Both Sides,
- 2) Two Parallel Lines are in Operation.

The test signals are obtained under various fault locations for the above configurations using PSCAD. They are *i)* 10% inside the zone1 *ii)* 10% outside the zone2, and *iii)* 10% before the relay location. Table 1 shows the case numbers for different fault conditions. In subsequent discussion these case numbers are used for referring to each case.

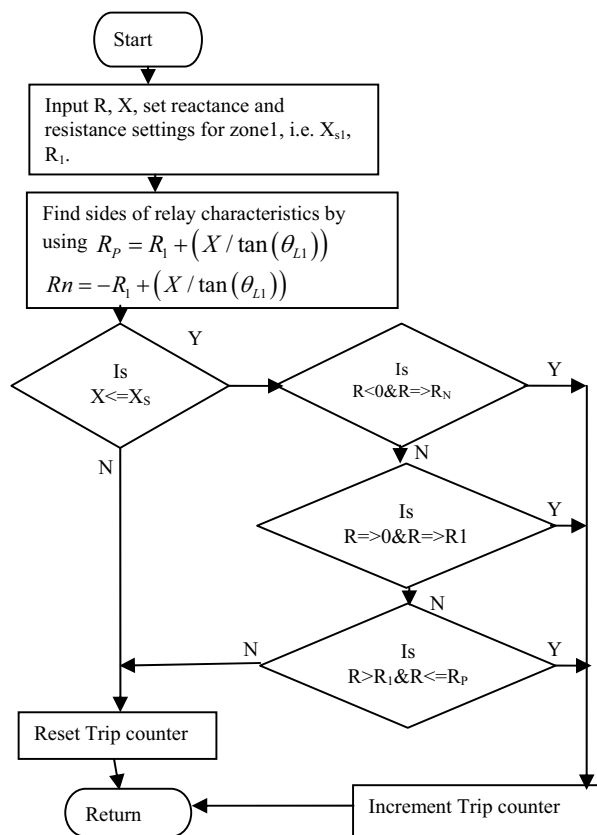

Fig. 7. Quadrilateral Relay Logic for Zone1.

The evaluation tests were conducted on conventional distance relay in order to compare its performance with that of adaptive distance relay. The fault data sets that are used in evaluating the adaptive distance relay has been used for comparing the performance of the conventional distance relay.

The table II indicates the comparative performance of both the relays. The impedance trajectories of Fig. 8 and Fig. 9 for both adaptive relay and conventional relay show clearly that the conventional relay overreaches. On the other hand the proposed adaptive relay operated correctly. In some cases, for example in the cases (a.2) and (a.4), the operating time of the adaptive relay is more, but it is operating correctly compare to conventional relay. We can also observe when the two lines are in operation, the conventional distance relay of zone 1 mal operated in zone2 (case (b.2)). This can be found by observing the R-X plots of Fig. 10. In some cases like case (b.4), where the trip count is fixed, even though the conventional relay operated but the impedance computed is erroneous [since it not compensated], thus final impedance value lies outside the reach of the relay. Thus relay under-reaches. This can be observed in the R-X plot of Fig. 11.

TABLE I
 DIFFERENTIAL CASES CONSIDERED FOR COMPARATIVE EVALUATION

Line status	Location of fault w.r. t.	Load applied	Inception of fault at voltage	Case no.
One line in operation	10% inside the zone 1 end	10% FL	Zero	a.1
			Peak	a.2
		90% FL	Zero	a.3
			Peak	a.4
	10% outside the zone 1 end	10% FL	Zero	a.5
			Peak	a.6
		90% FL	Zero	a.7
			Peak	a.8
Two lines in operation	10% inside the zone 1 end	10% FL	Zero	b.1
			Peak	b.2
		90% FL	Zero	b.3
			Peak	b.4
	10% outside the zone 1	10% FL	Zero	b.5
			Peak	b.6
		90% FL	Zero	b.7
			Peak	b.8

TABLE II
 RESULTS OF COMPARISON BETWEEN ADAPTIVE AND CONVENTIONAL DISTANCE RELAY

Fault condition (fault location)	R-X plot (Fig)	Operating Time		Operating Status * mal operation ✓ Correct operation	
		Conversely (Tripped in)	Adaptive Relay	Cone. Relay	Adaptive Relay
a.1 (Zone 1)	13	27ms, (Zone 1)	28ms	✓	✓
a.2 (Zone 1)	---	31ms, (Zone 1)	33ms	✓	✓
a.3 (Zone 1)	---	27ms, (Zone 1)	26ms	✓	✓
a.4 (Zone 1)	---	32ms, (Zone 1)	40ms	✓	✓
a.5 (Zone 2)	---	27ms, (Zone 1)	Zone 2	×	✓
a.6 (Zone 2)	15	25ms, (Zone 1)	Zone 2	×	✓
a.7 (Zone 2)	16	26ms, (Zone 1)	Zone 2	×	✓
a.8 (Zone 2)	---	24ms, (Zone 1)	Zone 2	×	✓
b.1 (Zone 1)	---	25ms	25ms	✓	✓
b.2 (Zone 1)	17	(Zone 2)	28ms	×	✓
b.3 (Zone 1)	---	25ms	24ms	✓	✓
b.4 (Zone 1)	18	21ms	21ms	✓	✓
b.5 (Zone 2)	---	(Zone 2)	Zone 2	✓	✓
b.6 (Zone 2)	19	(Zone 2)	Zone 2	✓	✓
b.7 (Zone 2)	---	(Zone 2)	Zone 2	✓	✓
b.8 (Zone 2)	---	(Zone 2)	Zone 2	✓	✓

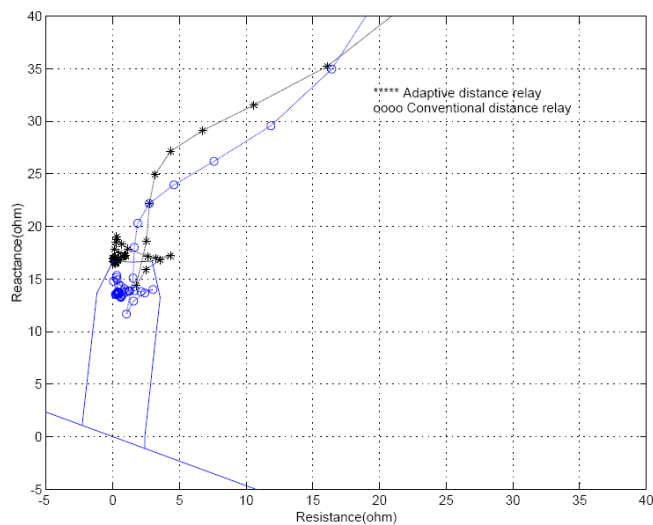

Fig. 8. R-X Diagrams of Adaptive and Conventional Relay for the case (a.6).

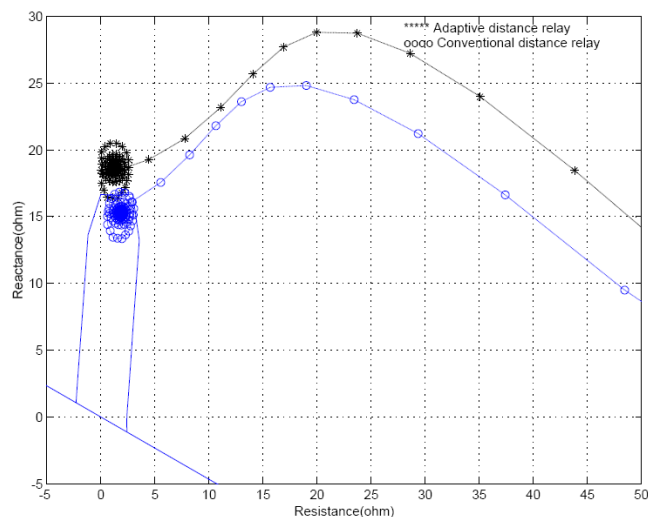

Fig. 9. R-X Diagrams of Adaptive and Conventional Relay for the case (a.7).

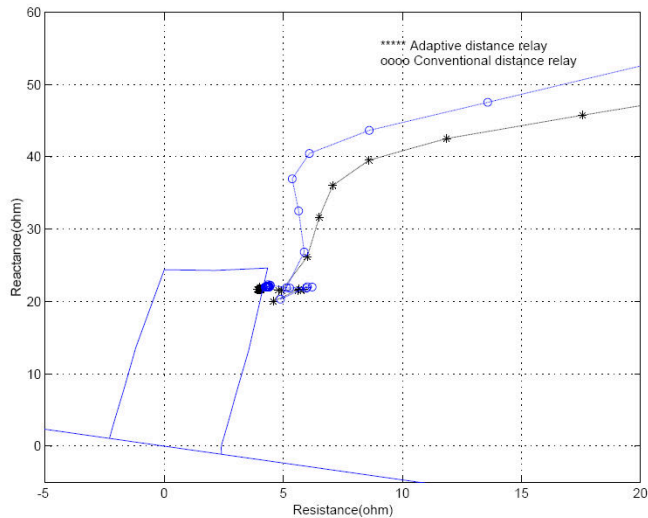

Fig. 10. R-X Diagrams of Adaptive and Conventional Relay for the case (b.2).

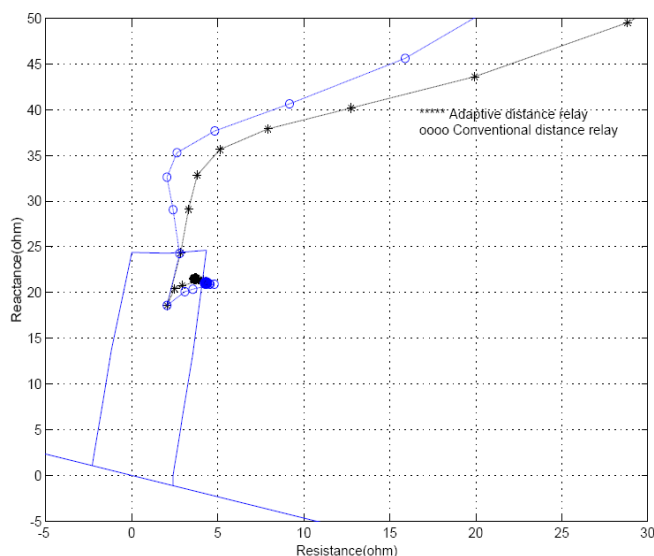

Fig . 11. R-X Diagrams of Adaptive and Conventional Relay for the case (b.4).

V. CONCLUSION

The adaptive distance relay described in this paper provides an enhanced distance protection for parallel lines. No remote signals like parallel line zero sequence current are required for proposed scheme. The proposed adaptive relay access the operating status of the parallel line through the substation PLC. The adaptation to the signal availability provides a built-in fallback scheme, which ensures the reliable operation under all conditions.

The developed quadrilateral trip characteristic with directionality feature is tested for the three-zone protection. The performance improvement of the proposed adaptive relaying has been verified on the simulated example system in PSCAD/EMTDC in comparison with conventional distance relay. The evaluation test results show the efficacy of adaptive distance relay over the conventional distance relay. Application of the new adaptive distance relay would provide an enhanced performance for distance protection on parallel lines with mutual coupling.

REFERENCES

- [1] A.G.Jongepier, L.van der Sluis, "Adaptive Distance Protection of a Double-Circuit Line", *IEEE Transactions on Power Delivery*, Vol.9, pp.1289-1297, July 1994.
- [2] Yi Hu, Damir Novosel, Murali Mohan saha, "An Adaptive Scheme for Parallel-Line Distance Protection", *IEEE Transactions on Power Delivery*, Vol.17, pp. 105-110, Jan2002.
- [3] M. H. J. Bollen, "Traveling-wave-based protection of double-circuit lines," *Proc. Inst. Elect. Eng.*, pt. C, vol. 140, no. 1, pp. 37-47, Jan.1993.
- [4] P. G. McLaren, I. Fernando, H. Liu, E. Dirks, G.W. Swift, and C. Steele, "Enhanced double circuit line protection," *IEEE Trans. Power Delivery*, vol. 12, pp. 1100-1108, July 1997.
- [5] R.D.Dunlop, R.Gutman, P.P.Marchenko, "Analytical Development of Loadability Characteristics for EHV and UHV Transmission lines", *IEEE Transactions on Power Apparatus and Systems*, Vol.PAS-98, pp. 606-617, April 1979.



S.G.Srivani was born in Bangalore, in 1963. She Received B.E (E&E).degree from Bangalore university, Bangalore in 1986,M.E.(power system) degree from Bangalore university, Bangalore in 1990 .She joined RV College of Engineering, Bangalore, India in 1990 as lecturer and presently working as Assistant professor in the department of Electrical and Electronics Engineering. At this moment she is pursuing PhD research program as part time research scholar at Dept. of Electrical & Electronics Engineering, National Inst. of Technology, Karnataka – Surathkal, Mangalore, India. She has published three technical research papers in various National and International conferences .Her areas of interest include power system protection, signal processing and power quality.



Chandrasekhar Reddy Atla was born in Kadapa, India, in 1981. He received his Batch (E&E).degree from S.V. University, Treaty in 2003, and M. Tech (Power and Energy Systems) degree from National Inst. of Technology-Karnataka, India. His areas of interest include power system protection, power system stability



K.P. Vittal (MIEEE'88) was born in Bellary, in 1964. He received his B.E. (E & E) degree from Mysore University, Mysore in 1985, M.E. (Applied Electronics) degree from Bharatiar University, Coimbatore in 1989, and Ph. D. from Mangalore University, Mangalore in 1999, all from India. Presently Dr.Vittal is serving as Professor at Dept. of Electrical & Electronics Engineering, National Inst. of Technology, Karnataka – Surathkal, Mangalore, India. He is member of IEEE, Life member of ISTE and IE (India). He has published 25 technical research papers in various National and International conferences and two papers in Int. Journals. His areas of interest include power system protection, power quality and design of embedded systems.