

Real Time Multi-Sensory Force Sensing Mat for Sports Biomechanics and Human Gait Analysis

D. Gouwanda and S. M. N. A. Senanayake

Abstract—This paper presents a real time force sensing instrument that is designed for human gait analysis purposes. It is capable of recording and monitoring ground reaction forces exerted by human foot during various activities such as walking, running and jumping in real time. In overall, force sensing mat mainly consists of three elements: the force sensing mat, signal conditioning circuit and data acquisition device. Force sensing mat is the mat that contains an array of force sensing elements. To control and process the incoming signal from the force sensing mat, Force-Logger and Force-Reloader are developed using National Instrument Labview. This paper describes the architecture of the force sensing mat, signal conditioning circuit and the real time streaming of the incoming data from the force sensing mat. Additionally, a preliminary experiment dataset is presented in this paper.

Keywords—Force platform, force sensing resistor, human gait analysis.

I. INTRODUCTION

AS the study on biomechanics is growing, various methods and tools have been developed to collect either dynamics or kinematics parameters of the human gait. And force platform emerges as one of the most common tools used to provide information on three orthogonal forces and moments exerted by human body. It is widely used in engineering and medical research, orthopedics, rehabilitation evaluation, prosthetics and other general industrial uses. If it is mounted properly, force platform is a very reliable and accurate device.

However, despite of its capabilities and performances, force platform has several limitations. One of its limitation is that force platform does not provide either qualitative or qualitative information on how the ground reaction forces are distributed on the human foot i.e. from toe to heel. Therefore, due to this reason, engineers and other various field researchers have designed and developed force sensing mat that is capable to visualize the force distribution of the human feet. Paradiso, et al used Polyvinylidene Fluoride polymer (PVDF) wires to develop a magic carpet that is capable of measuring human foot pressure [1]. Srinivasan, et al developed a pressure sensing floor that has one sensor per square centimeter, with sensor spaced 10 mm apart and each sensor has active area of 6 mm x 6 mm [2]. Robert and Gregory created a system for identifying people based on their footstep force profiles and have tested its accuracy against a

large pool of footstep data. This smart floor is able to identify users in their living and working environments [3].

With similar capabilities, real time force sensing instrument which has different architecture is introduced in this paper. The major features of this instrument are its high mobility, modularity, configuration flexibility, expandability and low cost. This instrument is highly mobile as it can be disassembled into 4 units for compact and easy storage. Additionally, this modular system is able to handle multiple force sensing mats. Furthermore, the configuration of the multiple force platforms is flexible. They can be placed on the floor for jumping analysis or placed on the wall for punching and kicking analysis. Expanding the application of this system for different analysis on human daily activities and sports can be as simple as analyzing different parameters from the main software. Lastly, this system is made of low cost components and the construction of the system is carried out in the laboratory environment without the need of any special tools or equipment [4].

This instrument contains an array of force sensing elements that is capable of monitoring and recording the movement pattern of a test subject in standing, walking, jumping and running. Additionally it is able to provide qualitative information on how the vertical ground reaction forces are exerted on each part of the human foot i.e. toe, middle foot and heel. Having this information, researches from various field are able to study the causes of injury in sports and human daily activities, design and determine appropriate footwear, and provide in-depth understanding on human gait properties in walking, running and jumping.

This work is carried out under research collaboration between Monash University Sunway Campus and Malaysia National Sports Institute (ISN). In the past two years, several research projects have been carried out on sports performance analysis and human gait pattern analysis. Significant research outcomes of these projects are highlighted in [4]-[13].

II. FORCE SENSING MAT ARCHITECTURE

Force sensing mat is a mat that contains 144 Force Sensing Resistors (FSR) which are distributed evenly over a 480 mm x 540 mm acrylic board. FSR is a thin film device which made of force sensitive material. FSR is not a load cell or strain gauge, though it exhibits similar properties [14]. In this work, two similar force sensing mats are developed. Both mats can be merged into one force sensing mat to provide larger movement area for the test subject to perform his/her activities.

Manuscript received April 29, 2008.

D. Gouwanda is with School of Engineering, Monash University, Sunway Campus, Malaysia, email: darwin_gouwanda@yahoo.com
S.M.N.A. Senanayake is with School of Engineering, Monash University, Sunway Campus, Malaysia; e-mail: senanayake.namal@eng.monash.edu.my

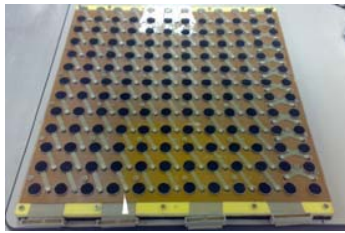

Fig. 1 Force Sensing Platform

Force sensing mat has a total of 5 layers that serve different purposes. Arrangement of these layers is shown in Fig. 2. The first layer is 3 mm thick acrylic board with 144 through holes to expose the sensing area of the sensors. The second layer is layer where the force sensing elements, FSRs are placed. The third layer is a customized Printed Circuit Board (PCB) that connects the sensing elements to four 40 ways connectors where the links between the mat and the signal conditioning circuit is established. The fourth layer is a rubber mat that protects the connection beneath the circuit board. And lastly, the fifth layer is a combination of 3 mm thick acrylic board and rubber mat. Acrylic board ensures the stability and rigidity of the platform while rubber mat prevents the platform from sliding while test subject performs his/her activities.

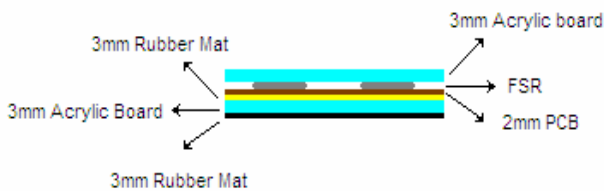

Fig. 2 Description of various layers in force sensing mat

III. SIGNAL CONDITIONING AND SWITCHING CIRCUIT

In overall, there are two major electrical circuitries. An each electrical circuitry has its own functionality and purposes. The first electrical circuitry is called signal conditioning circuit. As the name implies, it contains numerous operational amplifiers that condition and amplify the incoming signals from the force sensing mat.

Since the data acquisition device only has limited analog inputs, switching circuit is implemented. It contains numerous multiplexers that are able to switch the readings among the 144 force sensing elements. Furthermore, to accommodate the readings of the incoming signals, dual state switching method is implemented. In this method, the force sensing platform is divided into four main quadrants. Each quadrants has 36 sensing elements that are arranged in array. This arrangement is shown in Fig. 3.

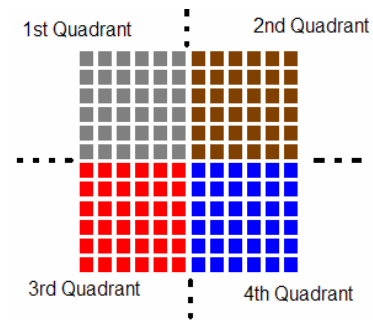

Fig. 3 Schematic diagram of sensors arrangement in quadrant form

In the first state, each quadrant contains six multiplexers. Each multiplexer is assigned to switch signal readings among six force sensing element in row manner., therefore this state is also called row selection state. In the second state, which is also called as column selection state, output signals from first state are then multiplexed and transmitted to data acquisition device using a single multiplexer. A schematic diagram of the switching method is shown in Fig. 4

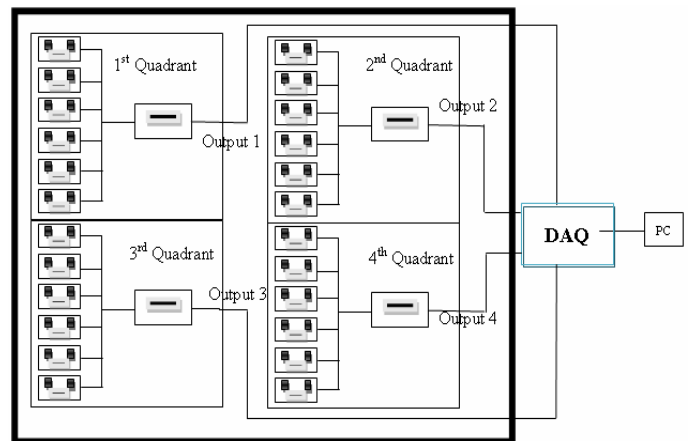

Fig. 4 Schematic diagram of arrangements of multiplexers in quadrants with connectivity to the computer

When a digital state is selected, multiplexers in row column selection state will receive voltage readings from the force sensing element. At this instant, second digital state will be selected in order to enable multiplexer in column selection state to receive voltage readings from the multiplexers in row selection state. A flowchart of this method is presented in Fig. 5

As the overall system contains of numerous force sensing elements, operational amplifiers and multiplexers, customized Printed Circuit Board (PCB) is designed and developed using CircuitMaker2000. Both signal conditioning and switching circuit for one quadrant are contained in a circuit board as shown in Fig. 6. Designing the signal conditioning circuit through CircuitMaker2000 provides in-depth understanding of electrical behavior of the circuit.

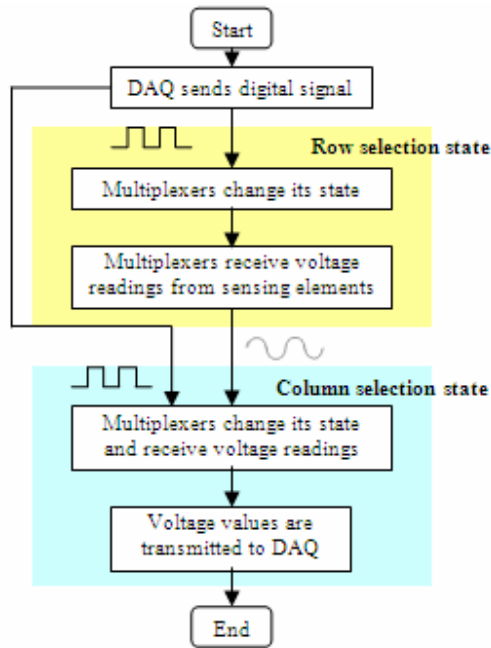

Fig. 5 Flowchart of dual state switching method

Having this knowledge, problem arises from system testing and debugging processes can be reduced significantly. Furthermore, it is able to decrease the required resources to develop this instrument.

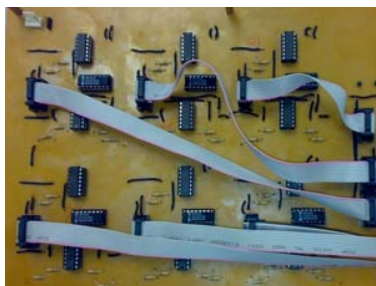

Fig. 6 Signal conditioning and switching circuit

IV. REAL TIME STREAMING THROUGH DATA ACQUISITION DEVICE AND SOFTWARE ARCHITECTURE

Real time streaming from the force sensing platform is achieved by using NI PCI-6070E Data Acquisition card (DAQ). The major strength of this data acquisition device is its high sampling rate of 1.25 MS/s [15]. By having a relatively high sampling rate, this device is able to process and compute all the relevant data in real time. In this system, it is assigned to receive the incoming signal from the signal conditioning and switching circuit, perform analog-to-digital conversion and transmit them to a computer for further processing procedures.

To visualize the incoming signals from the platforms interactively, Force-Logger and Force-Reloader are developed using National Instrument LabVIEW as shown in Fig 8. Force-Logger and Force Reader are capable of providing qualitative information on how ground reaction forces are

exerted on each part of the foot i.e. toe, middle foot and heel. This information is essential as it is able to determine whether the test subject has good gait posture and to determine whether the test subject is exerting the correct amount of force on each part of the foot in walking, running and jumping. Additionally, both programs have similar features and Graphical User Interface (GUI) so that user that is familiar with Force-Logger is able to operate Force-Reloader and vice versa, without facing any difficulties. The only difference between both softwares is at their functionalities. Force Logger is used to stream, process and display the incoming data graphically while Force-Reloader is used to reload the experiment data taken previously.

A. Software Architecture of the Force-Logger

Force-Logger is software that is capable of streaming, processing and displaying the incoming data graphically in real time. When it is executed, it performs three major task sequentially. The first task is to collect the relevant data from the force sensing mat via data acquisition device. The data of interest here is the voltage values when there are forces exerted on the force sensing mat. The second task is to convert voltages to appropriate force values and the third task is to display the information of the forces on the front panel and compute additional parameters i.e. maximum and minimum applied force, the jumping flight time and maximum jumping height.

To accommodate one of the strong features, where two force sensing mats can be merged to one mat to provide larger sensing area, Force-Logger has two different operational modes: single mode and combined mode. In single mode, each force sensing mat is treated individually. The signal acquisition and analysis are performed separately. In combined mode, both force sensing mat are merged to one and treated as one large sensing mat. Screenshots of single operational mode and combined operational mode are shown in Fig. 8 and Fig. 9 respectively

The complete software architecture of the Force Logger can be summarized as follow:

1. Prompt the user to input the relevant information such as name, age, height and weight of the test subjects and to choose the specific activity i.e. walking, running and jumping in order to obtain the desired outputs
2. Prompt the user to select one of the operational modes, single mode and combined mode.
3. Scan the force sensing mats to obtain the voltage reading from data acquisition devices. The voltage values are then converted to force values.
4. Determine the total forces exerted on both force sensing mats at any instant.
5. Compute instantaneous forces, such as maximum force, minimum force and mean force exerted on both platforms.
6. Display the forces distribution on the intensity graph and display the total amount of forces applied on the force versus time graph.
7. Prompt user to save relevant experiment data for future references.

8. Compute the parameters of specific activity based on force data obtained i.e. jumping flight time, take-off velocity, and jumping height
9. Display the computed parameters on the front panel.

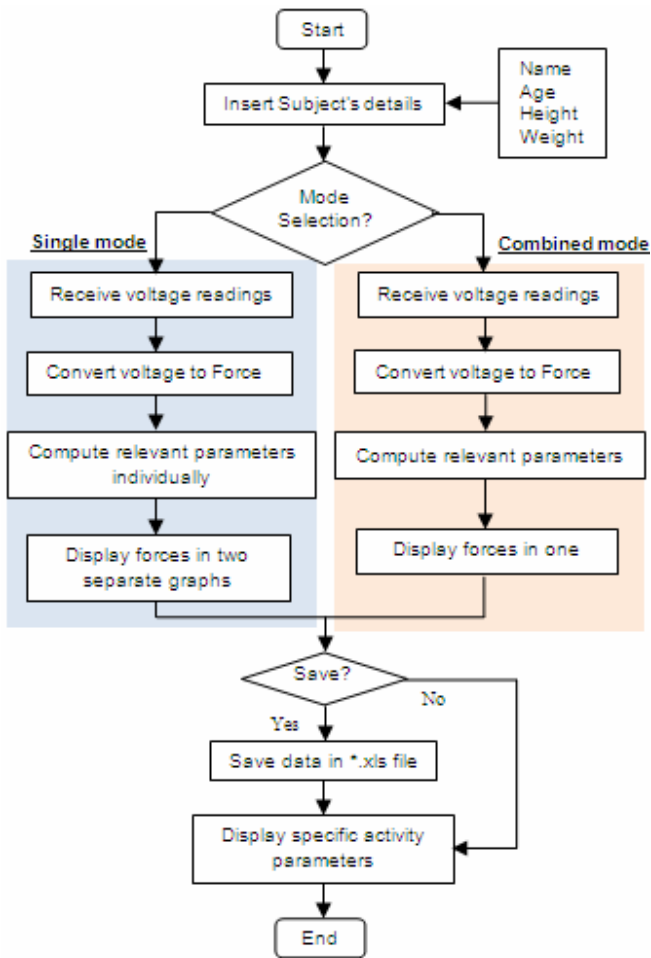

Fig. 7 Flowchart of Force-Logger software architecture

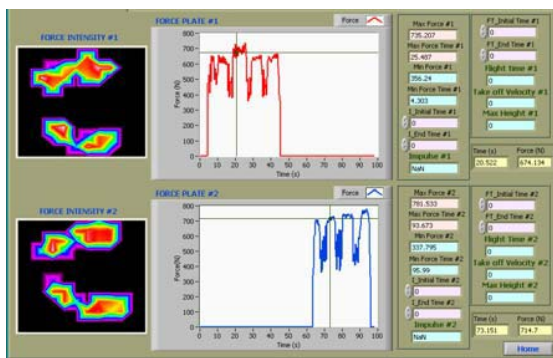

Fig. 8 Force-Logger in single mode

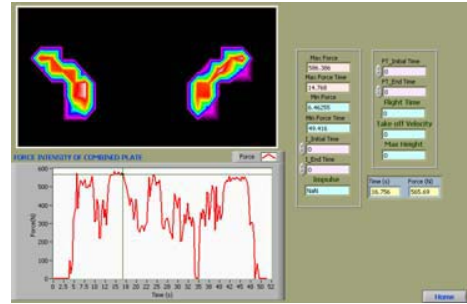

Fig. 9 Force-Logger in combined mode

B. Force-Reloader

Second software, Force-Reloader is used to load the experiment data taken previously. It displays the test subject's details i.e. names, age, height and weight, time and date when the experiment was conducted, the operational mode, and the force distribution data. Once the data is completely loaded, user can easily perform required analysis such as maximum and minimum applied forces, jumping flight time and maximum jumping height as well.

The complete software architecture of the Force Reader can be summarized as follow:

1. Prompt user to select relevant experiment data taken previously
2. Display the relevant information regarding the test subject i.e. name, age, height and weight and date/time when the experiment was conducted
3. Based on operational mode, it displays the force distribution on the intensity graph and the total amount of forces applied on the force versus time graph.
4. Compute the parameters of specific activity i.e. jumping flight time, take-off velocity, etc.

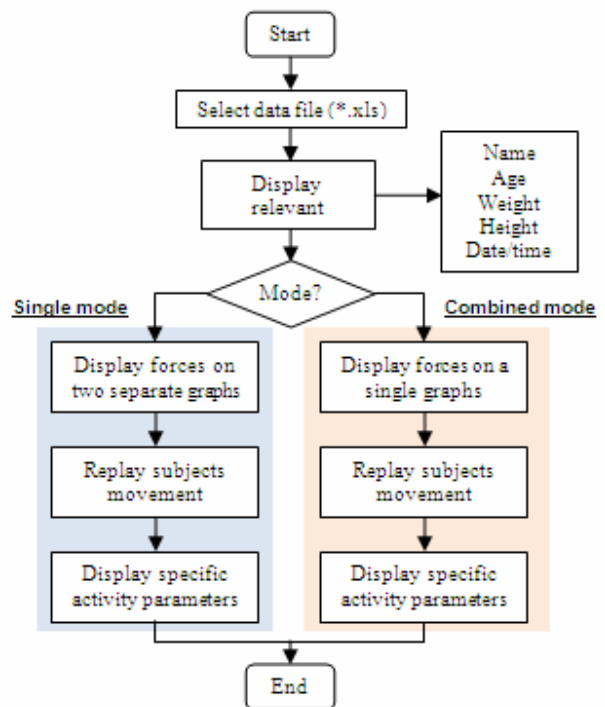

Fig. 10 Flowchart of Force-Reloader software architecture

V. ACTIVITIES ON FORCE SENSING MAT

To evaluate the overall performance of this instrument, there are several activities are performed on the force sensing mats. These activities include standing walking, running and jumping. Additionally, for jumping event, one leg jump, two leg jump and counter movement jump experiment have been considered as well. These experiments have been carried out successfully on 25 test subjects. In each experiment, test subjects are instructed to perform each activities three times. A summary of experiment procedures are as follow:

1. Brief test subjects regarding the experiments activities and procedures in standing still, walking, running and jumping
2. Record test subjects age, name, height and weight.
3. Record the force distributions on test subject's foot and other necessary parameters during standing still, running and walking in real time as shown in Fig. 8 and Fig. 9
4. Save the recorded experiment data for future references.
5. Request test subjects to perform one leg jump, two leg jump and counter movement jump three times
6. Record the force distribution during jumping and landing phase as shown in Fig. 12
7. Save the recorded experiment data for future references.

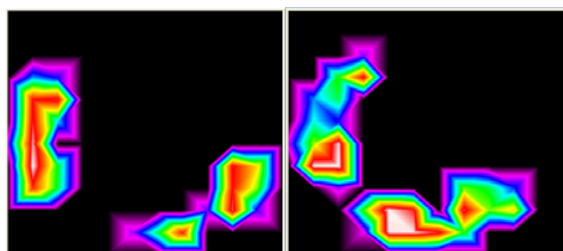

Fig. 11 Forces distribution of human feet in standing

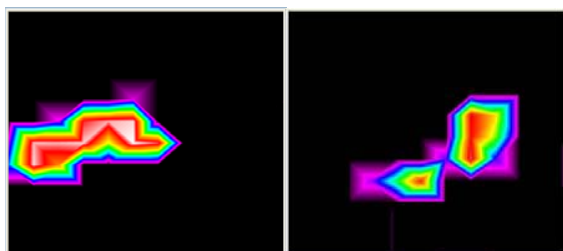

Fig. 12 Forces distribution of human foot in one leg jump

One of the experiment dataset which contains data of 6 test subjects is presented in Table I, Table II, and Table III. This dataset contains information on test subjects' average jumping parameters i.e. maximum jumping height (JH), jumping takeoff velocity (JV) and jumping flight time (JT).

From Table I to Table III, it can be observed that different test subjects have different jumping capabilities regardless of their height and weight. By comparing Table I and Table II, it can be seen that all test subjects are able to jump higher and achieve larger takeoff velocity and longer jumping flight time in counter movement jump. Another observation that can be perceived is that real-time force sensing instrument is

performing well in monitoring and recording human motion such as walking, running and jumping, in real time.

TABLE I
 EXPERIMENT DATASET ON ONE LEG JUMP

No.	Weight (Kg)	Height (m)	JV(m/s)	JH(m)	JT(s)
1	51.70	163	1.518	0.112	0.312
2	57.00	163	1.393	0.107	0.281
3	62.60	165	1.711	0.152	0.351
4	69.10	170	1.772	0.161	0.366
5	74.00	175	1.621	0.138	0.442
6	76.50	179	1.675	0.142	0.349

TABLE II
 EXPERIMENT DATASET ON TWO LEG JUMP

No.	Weight (Kg)	Height (m)	JV(m/s)	JH(m)	JT(s)
1	51.70	163	1.519	0.123	0.321
2	57.00	163	2.513	0.119	0.512
3	62.60	165	1.712	0.142	0.342
4	69.10	170	1.724	0.165	0.366
5	74.00	175	2.553	0.125	0.521
6	76.50	179	2.721	0.149	0.558

TABLE III
 EXPERIMENT DATASET ON COUNTER MOVEMENT JUMP

No.	Weight (Kg)	Height (m)	JV(m/s)	JH(m)	JT(s)
1	51.70	163	1.581	0.132	0.318
2	57.00	163	2.590	0.371	0.741
3	62.60	165	2.471	0.346	0.498
4	69.10	170	2.293	0.299	0.472
5	74.00	175	3.651	0.679	0.739
6	76.50	179	2.221	0.280	0.451

VI. CONCLUSION

FSR, as force sensing elements have been successfully implemented in the force sensing mat. An array of FSR on the acrylic board has given effective force sensing area with dimension of 480 mm x 540 mm. It is able to display the force distribution of human feet in various activities.

There are two integration circuits made in this work: signal conditioning circuit and double layer switching circuit. The main function of the signal conditioning circuit is to condition and amplify the incoming signal from the force sensing mats. The main function of the switching circuit is to switch signals among the sensing elements and pass them to the data acquisition device for further signal processing procedures.

In this work, data acquisition device from National Instrument has enabled the real time monitoring of the force distribution of human foot in standing, walking, running and jumping. Finally, experiments on human daily activities are conducted on test subjects that have various age, height and weight. From the experimental results, it can be seen that the force sensing mat is performing well and it has promising prospect in the future. Furthermore, it clearly indicates that it

can be used in various fields, such as sports, clinical rehabilitation and research as well as surveillance and security system.

REFERENCES

- [1] J. Paradiso, C. Ablner, K. Y. Hsiao, and M. Reynolds, "The Magic Carpet: Physical Sensing for Immersive Environments", *Proc. of the CHI '97 Conference on Human Factors in Computing Systems*, 1997, ACM Press, NY, pp 277-278
- [2] P. Srinivasan, G. Qian, D. Birchfield, and A. Kidané, "Design of a pressure sensitive floor for multimodal sensing" *Proceedings of the International Conference on Non-visual & Multimodal Visualization*, London, UK, 2005
- [3] J. O. Robert, and A. D. Gregory, "The smart floor: A mechanism for natural user identification and tracking", *Proc. Conference on Human Factors in Computing System*, 2000, ACM Press, NY, pp. 275-276
- [4] B. H. Khoo, S. M. N. A. Senanayake, D. Gouwanda and B. Wilson, "A portable vertical jump analysis", *The Impact of Technologies on Sports*, 2007, Taylor & Francis Group, London, pp. 637-642
- [5] D. Gouwanda and S. M. N. A. Senanayake, "Instrumented Multilayer Sensorized Floor for Sports", *Proc. 5th International Conference on Computing, Communications and Control Technologies (CCCT)*, 2007
- [6] S. M. N. A. Senanayake, D. Looi, M. Liew, K. Wong and J. W. Hee, "Smart Floor Design for Human Gait Analysis" *The Impact of Technologies on Sports*, 2007, Taylor & Francis Group, London, pp. 189-192
- [7] A.A. Bakar, and S. M. N. A. Senanayake, "Intelligent System for Soccer Gait Pattern Recognition", *The Impact of Technologies on Sports*, 2007, Taylor & Francis Group, London, pp. 415-420
- [8] A.A. Bakar, S. M. N. A. Senanayake, R. Ganason and B.D. Wilson, "Pattern Recognition in Gait Analysis", *The Impact of Technologies on Sports*, 2007, Taylor & Francis Group, London, pp. 169-174
- [9] [8] S. M. N. A. Senanayake and T. K. Khoo, "Intelligent Musculosoccer Simulator", *The Impact of Technologies on Sports*, 2007, Taylor & Francis Group, London, pp. 409-414
- [10] S. M. N. A. Senanayake, A. W. Y. Wong, and B. D. Wilson, "Accelerometry in Motion Analysis", *The Impact of Technologies on Sports*, 2007, Taylor & Francis Group, London, pp. 474-484
- [11] S. M. N. A. Senanayake and A. A. Gopalai, "Real Time Instrumented System for Gait Analysis", *Proc. 5th International Conference on Computing, Communications and Control Technologies (CCCT)*, 2007
- [12] S. M. N. A. Senanayake and Y. Z. Chong, "Intelligent System for Soccer Gait" *International Conference on Automation Science and Engineering*, Shanghai, 2006 pp. 204-209
- [13] S. M. N. A. Senanayake and Y. Z. Chong, "Analysis of Soccer Actions Using Wireless Accelerometers", *The 4th International Conference in Industrial Informatics*, Singapore, 2006, pp. 664-669
- [14] *Force Sensing Resistor Integration Guide and Evaluation Parts Catalog*, Interlink Electronics, Camarillo, CA
- [15] *DAQ E Series – E Series User Manual*, National Instrument, Austin, TX, February 2007
- [16] T. Lee, Y. Kwon, and H. Kim, "Smart location tracking system using FSR (Force Sensing Resistor)" *International Conference on Artificial Reality and Telexistence*, 2004

Darwin Gouwanda received his degree in Mechatronics engineering from Monash University Sunway Campus, Malaysia in 2006. The author is currently pursuing his Masters of Engineering Science (Research) under supervision of S. M. N. A. Senanayake. He is a graduate member of IEEE Monash University Sunway Campus Student Branch. His research areas include human biomechanics and gait analysis, sports engineering and artificial intelligence.

S. M. N. A. Senanayake is currently with Monash University Sunway Campus where he leads the research group Intelligent, Integrated and Interactive Systems (IIIS). He has been recently appointed as the chairman of IEEE Asia-Pacific Robotics & Automation Development Council – Malaysia Section. Prior to Monash, he has been working with three different universities; Chalmers University of Technology, Sweden, Johannes Kepler University of Linz, Austria and University of Peradeniya, Sri Lanka holding key academic and research positions. During his 18 years of research experience, he managed to publish over 72 publications in international conferences, journals and book chapters. He was one of the editors of three books published based on the research outcomes. He was the special session organizer for various international conferences, in particular IEEE conferences. He is one of the reviewers in IEEE publications and Elsevier publications.

He has initiated research with Sports Biomechanics Centre, National Sports Complex, in which his research team carried out special research projects of national interest. Having engaged in this area of research, Interactive Multilayer Sensorized Smart Floor has been developed under his leadership and currently in the process of patenting the device. Dr. Arosha is the leader of MoU between Monash and National Instruments. He carried out various special research projects under this MoU which are mainly targeting industrial needs.

He is a member of research committee of Monash and he is the student counselor of IEEE student branch at Monash