

# A New Distribution Network Reconfiguration Approach using a Tree Model

E.Dolatdar, S.Soleymani, B.Mozafari

**Abstract**—Power loss reduction is one of the main targets in power industry and so in this paper, the problem of finding the optimal configuration of a radial distribution system for loss reduction is considered. Optimal reconfiguration involves the selection of the best set of branches to be opened, one each from each loop, for reducing resistive line losses, and relieving overloads on feeders by shifting the load to adjacent feeders. However, since there are many candidate switching combinations in the system, the feeder reconfiguration is a complicated problem. In this paper a new approach is proposed based on a simple optimum loss calculation by determining optimal trees of the given network. From graph theory a distribution network can be represented with a graph that consists a set of nodes and branches. In fact this problem can be viewed as a problem of determining an optimal tree of the graph which simultaneously ensure radial structure of each candidate topology. In this method the refined genetic algorithm is also set up and some improvements of algorithm are made on chromosome coding. In this paper an implementation of the algorithm presented by [7] is applied by modifying in load flow program and a comparison of this method with the proposed method is employed. In [7] an algorithm is proposed that the choice of the switches to be opened is based on simple heuristic rules. This algorithm reduce the number of load flow runs and also reduce the switching combinations to a fewer number and gives the optimum solution. To demonstrate the validity of these methods computer simulations with PSAT and MATLAB programs are carried out on 33-bus test system. The results show that the performance of the proposed method is better than [7] method and also other methods.

**Keywords**—Distribution System, Reconfiguration, Loss Reduction, Graph Theory, Optimization, Genetic Algorithm

## I. INTRODUCTION

NETWORK reconfiguration is one of the feasible methods for reducing the distribution network loss in which the power flow in the distribution network is altered by opening or closing the appropriate switches on the feeders, thus The reconfiguration of a distribution system is a process, which alters the feeder topological structure by changing the open/ close status of the sectionalizing (normally closed) and the tie switches (normally open) in the system. The benefits of feeder reconfiguration include: (i) restoring power to any outage partitions of a feeder, (ii) relieving overloads on feeders by shifting the load in real time to adjacent feeders, and (iii) educing resistive line losses.

In this paper an algorithm is proposed based on graph theory and identified an effective switch status configuration of distribution system for the minimum loss reduction. Since there are many candidate switching combinations in the system, the feeder reconfiguration is a complicated problem. The discrete nature of the switch values makes it a discrete optimization problem.

In the recent years, many algorithms have been developed to solve this problem. Most of these algorithms are based on heuristic techniques, conventional optimization approaches and artificial intelligence techniques.

More than 30 years ago, the French engineers A. Merlin and H. Back [1] perceived an opportunity to reduce technical losses by exploring a change in the status of normally closed and normally open switches. They proposed the “network reconfiguration problem”, for which the solution should provide the best status for all the switches in a primary distribution network, best in the sense that they provide a radial configuration supplying loads with the minimum of power loss. However, because the number of possible solutions for the network reconfiguration problem grows exponentially with the number of switches, it is difficult to find an optimal solution when the size of network increases. In addition to network reconfiguration for loss reduction, load balancing is also taken into account in [2]. The single loop optimization is one of the simple methods based on simplex algorithm to reconfigure the system [3]. This scheme quickly checks the possibilities of switch positions for the minimum loss configuration and proposes a heuristic scheme to develop the optimal switch plan with minimum switch operation. At present, new methods based on artificial intelligence have been used. Chiang et al. [4] presented a simulated annealing (SA) method to solve the reconfiguration problem, in which the SA was very time-consuming. It is needed to apply the improved SA with high speed to handle the reconfiguration problem. For the first time, genetic algorithm (GA) was applied to the global optimal solution in [5], which has shown a better performance over the SA approach.

In this paper a comparative study of using two new methods for distribution network optimal reconfiguration is presented. In the first method an algorithm is proposed by [7], such that the choice of the switches to be opened is based on simple heuristic rules in which some improvements are made on load flow pattern. This algorithm reduce the number of load flow runs and also reduce the switching combinations to a fewer number and gives the optimum solution. This process is accomplished with PSAT program and study results are given in this paper. The second method is simple optimum loss calculation by determining optimal trees of the 33-bus test system. The refined genetic algorithm is used and the GA<sup>1</sup> method is

E.Dolatdar, M.Sc of Electrical Engineering \_Islamic Azad University Science and Research Branch, Tehran-Iran.(Corresponding author. Tel.:+989143553362 E-mail address: E.dolatdar@gmail.com ).

S.Soleymani, and B.Mozafari are with the Department Of Electrical Engineering \_Islamic Azad University Science and Research Branch, Tehran-Iran.(Corresponding author. Tel.:+989123332659.E-mail addresses:Soodabeh\_soleymani@yahoo.com, Mozafari\_babak@yahoo.com

further refined by modifying the string structure .To demonstrate the validity of these methods computer simulations with Matlab program are carried out on 33-bus test system and the results show that the performance of the proposed method with graph theory and GA optimization is better than the first method and also other methods.

## II. AN IMPLEMENTATION OF THE NEW HEURISTIC METHOD FOR OPTIMAL NETWORK RECONFIGURATION

The main aim of this paper is to present a methodology for reconfiguration a distribution network with the objective of minimizing the electric line losses. In this section, a new heuristic method is implemented for determining the minimum loss configuration of a radial distribution system. This solution starts with initial configuration with all NO<sup>2</sup> switches are in open position. The voltage differences across all NO switches and the two node voltages of each NO switch are computed using load flow with PSAT program. Among all the tie switches, a switch with maximum voltage difference is selected first subject to the condition that the voltage difference is greater than the pre-specified value. The NO switch with the maximum voltage difference is closed and the sectionalize switches are opened in sequence starting from the minimum voltage node of the NO switch. The power losses due to each sectionalize switch are calculated and the opening sectionalize switches are stopped when the power loss obtained due to previous sectionalizing is less than the current one. As the power loss due other sectionalize switches is more than the current, it is not necessary to open the sectionalize switches further in the loop. Based on the above procedure, the best switching combination of the loop is noted. The same procedure is repeated to all the remaining NO switches.

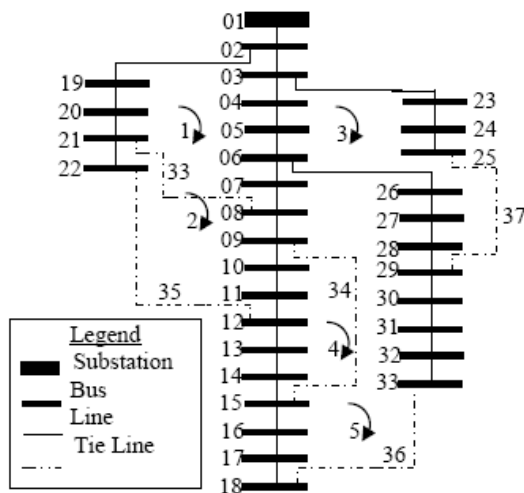

Fig. 1 Initial configuration of the 33-bus test system

- 1- Genetic Algorithm
- 2- Normally Open

The distribution system for reconfiguration consists of 33-buses and five normally open switches. The normally open switches are 33 , 34 , 35 , 36 and 37 and normally close switches are 1 to 32 as shown in figure (1). For this base case , the initial losses with applying PSAT program simulation for Goswami , Basu test system [6] are 200.5 KW . The line and load data of 33-bus test system are given in table I . The system base is V = 12.66 kV and S=10MVA.The PSAT simulations for 33-bus test system before and after reconfiguration are shown in Figs. a and b at the appendix, respectively.

TABLE I  
 NETWORK DATA FOR 33 – BUS SYSTEM

Line No.	From Bus	To Bus	R (Ω)	X (Ω)	Real Power (KW)	Reactive Power (KVAR)
1	1	2	0.0922	0.0470	100.0	60.0
2	2	3	0.4930	0.2511	90.0	40.0
3	3	4	0.3660	0.1864	120.0	80.0
4	4	5	0.3811	0.1941	60.0	30.0
5	5	6	0.8190	0.7070	60.0	20.0
6	6	7	0.1872	0.6188	200.0	100.0
7	7	8	0.7114	0.2351	200.0	100.0
8	8	9	1.0300	0.7400	60.0	20.0
9	9	10	1.0440	0.7400	60.0	20.0
10	10	11	0.1966	0.0650	45.0	30.0
11	11	12	0.3744	0.1238	60.0	35.0
12	12	13	1.4680	1.1550	60.0	35.0
13	13	14	0.5416	0.7129	120.0	80.0
14	14	15	0.5910	0.5260	60.0	10.0
15	15	16	0.7463	0.5450	60.0	20.0
16	16	17	1.2890	1.7210	60.0	20.0
17	17	18	0.7320	0.5740	90.0	40.0
18	2	19	0.1640	0.1565	90.0	40.0
19	19	20	1.5042	1.3554	90.0	40.0
20	20	21	0.4095	0.4784	90.0	40.0
21	21	22	0.7089	0.9373	90.0	40.0
22	3	23	0.4512	0.3083	90.0	50.0
23	23	24	0.8980	0.7091	420.0	200.0
24	24	25	0.8960	0.7011	420.0	200.0
25	6	26	0.2030	0.1034	60.0	25.0
26	26	27	0.2842	0.1447	60.0	25.0
27	27	28	1.0590	0.9337	60.0	20.0
28	28	29	0.8042	0.7006	120.0	70.0
29	29	30	0.5975	0.2585	200.0	600.0
30	30	31	0.9744	0.9630	150.0	70.0
31	31	32	0.3105	0.3619	210.0	100.0
32	32	33	0.3410	0.5302	60.0	40.0
33	21	8	2.0000	2.0000	-	-
34	9	15	2.0000	2.0000	-	-
35	12	22	2.0000	2.0000	-	-
36	18	33	0.5000	0.5000	-	-
37	25	29	0.5000	0.5000	-	-

The voltage differences across all NO switches are calculated with applying load flow in the PSAT program for the network shown in fig. 1 and results are shown in Table II. It is observed that the maximum voltage difference occurs across NO switch 35 which is greater than the specified value ( $\epsilon$ ). Hence, the tie switch 35 is closed first as the voltage differences across the remaining NO switches are smaller in magnitude.

TABLE II  
 VOLTAGE DIFFERENCE ACROSS ALL OPEN TIE SWITCHES

S.No	Tie switch No	Voltage difference across tie switch (pu)
1	33	0.0443
2	34	0.0178
3	35	0.0580
4	36	0.0035
5	37	0.0372

Now, if the tie switch 35 is closed, a loop will be formed and total number of branches including tie branch in the loop will be 14. These branches are 12-11, 11-10, 10-9, 9-8, 8-7, 7-6, 6-5, 5-4, 4-3, 3-2, 2-19, 19-20, 20-21, 21-22 and 22-12. Opening of each branch in this loop is an option. But opening of some of the branches causes the violation of the constraints and gives the infeasible solution. In this algorithm, sectionalize branches are opened (to retained the radiality) either left or right of the selected tie switch based on the minimum voltage node of the tie switch.

This procedure is explained as follows. The two node voltages of the tie switch 35 are evaluated and the minimum of two node voltages is noted. In this case, the minimum node voltage of the tie switch 35 is 12 because the voltage of node 12 is equal to 0.96176 and node voltage 22 is 0.97401. Therefore, one branch at a time in the loop is opened starting from the node 12 and power loss due to each objective is obtained till the power loss (PL<sub>q+1</sub>) due to current objective is greater than the previous objective (PL<sub>q</sub>). In this loop, the first sectionalize branch (12-11) is opened as it adjacent to the node 12 and power loss is computed and shown in Table VI. In same manner, next adjacent sectionalize branches 11-10, 10-9, 9-8, and 8-7 are opened one at a time in sequence and power loss is computed and shown in the Table VI. As the power due to sectionalize branch 8-7 is greater than 9-8, the optimal opening branch in the loop is between the nodes 9 and 8. Further opening of the branches beyond the branch 8-7 in the loop, is giving either more power loss than the minimum already obtained at the branch 9-8 or infeasible solution.

Hence, the opening of the remaining branches 7-6, 6-5, 5-4, 4-3, 3-2, 2-19, 19-20, 20-21, 21-22 and 22-12 are discarded. The optimal radial loop for the first switching operation is obtained by closing the tie switch 35 and opening the branch between the nodes 9 and 8. The advantage of this procedure is that it is not necessary to visit all the sectionalizing switches in the loop. Therefore, the search space of sectionalizing switches in the loop is drastically reduced. For the second switching operation, the voltage difference across remaining tie switches (discarding tie switch 35) are computed and shown in Table III.

TABLE III  
 VOLTAGE DIFFERENCE ACROSS ALL OPEN TIE SWITCHES

S.No	Tie switch No	Voltage difference across tie switch (pu)
1	33	0.0139
2	34	0.0083
3	36	0.0120
4	37	0.0286

From Table III, it is observed that the maximum voltage difference occurs across tie switch 37 and it is greater than the specified value ( $\epsilon$ ). The minimum voltage node of the tie switch 37 is 29 because the voltage of node 29 is equal to

0.95962 and node voltage 25 is 0.96226. Repeating the same procedure as in case of tie switch 35, the optimal radial configuration for the second switching operation is obtained by closing the tie switch 37 and opening the sectionalize branch between the nodes 28 and 29. Among the tie switches 33, 34 and 36, the voltage difference across tie switch 36 is greater than remaining two and is shown in Table IV.

TABLE IV  
 VOLTAGE DIFFERENCE ACROSS ALL OPEN TIE SWITCHES

S.No	Tie switch No	Voltage difference across tie switch (pu)
1	33	0.0033
2	34	0.0083
3	36	0.0101

Therefore, the tie switch 36 is selected for the third switching operation as voltage difference is greater than the specified value. The minimum voltage node of tie switch 36 is 33 because the voltage of node 33 is equal to 0.93972 and node voltage 18 is 0.94005. Repeating the same procedure as in case of tie switch 35, the optimal radial configuration for third switching operation is obtained by closing the tie switch 36 and open the sectionalize branch between the nodes 33 and 32. The voltage difference across the remaining two tie switches 34 and 33 are shown in Table V.

TABLE V  
 VOLTAGE DIFFERENCE ACROSS ALL OPEN TIE SWITCHES

S.No	Tie switch No	Voltage difference across tie switch (pu)
1	33	0.0016
2	34	0.0100

For fourth switching operation, tie switch 34 is considered as the voltage difference across it is greater than 33 and it is also greater than the specified value. The minimum voltage node of 34 is 15 because the voltage of node 15 is equal to 0.9501 and node voltage 9 is 0.95345. In this case the optimal configuration of the loop is obtained by closing the tie switch 34 and opening the sectionalize branch between the nodes 15-14. Since the voltage difference across the tie switch 5 is less than the specified value, the closing of it will not cause any reduction in the power loss. Hence this switching operation is discarded. The algorithm is tested on few examples and it was found that a values of  $\epsilon=0.01$  gives the satisfactory results.

TABLE VI  
 POWER LOSS IN EACH LOOP, MINIMUM NODE VOLTAGES OF THE SWITCHES, SWITCHES OPEN

Tie switch (Closed)	Minimum node voltage of the switch	Sectionalize switch open between nodes	Power loss (p.u)
35	12	12-11	0.01558
		11-10	0.01542
		10-9	0.01531
37	29	<b>9-8</b>	<b>0.01572</b>
		8-7	0.01559
		<b>29-28</b>	<b>0.01476</b>
		28-27	0.01508
36	33	<b>33-32</b>	<b>0.01464</b>
		32-31	0.01534
34	15	<b>15-14</b>	<b>0.01461</b>
		14-13	0.01494

The power loss before reconfiguration is 200.5 kW and reconfiguration is 146.1 kW. From the results it is observed that reduction in power loss is 54.4 kW which is approximately 27.13 %. The number of all load flow runs required for the entire process is 26 whereas it is 29 in case of Baran and Wu. The saving in total loss by the proposed method is higher than the proposed method by Kashem [8] and Final open switches in this method are {33,14,8,32,28} .

### III. Radial distribution power flow in Complex mode

The purpose of distribution network reconfiguration is to find a radial operating structure that minimizes the system power loss. Thus, the following model can represent the reconfiguration problem :

$$\text{Min } P_{\text{loss}} = \sum_{i=1}^n R_i I_i^2 \quad (1)$$

where  $I_i$  is the current in branch  $i$ ;  $R_i$  is the resistance of branch  $i$  and  $n$  is the total number of branches.

In this study , in order to get the precise branch current and system power loss, a radiation distribution network load flow method is presented. Since the distribution network is a simple radial tree structure, in which the ratio of R/X is relatively big , even bigger than 1.0 for some transmission lines ,neither P\_Q decoupled method nor Newton\_Raphson method is suited to compute the distribution network load flow. Therefore, a radiation distribution network load flow method is presented in this study .

This section presents an efficient algorithm to solve the radial distribution power flow problem in complex mode. In this method the relationship between the complex bus powers and complex branch powers is expressed as element incidence matrix that denoted by  $K$ .

For distribution networks KCL can be applied easily by developing the element incidence matrix ( $K$ ). KCL at every node is given by:

$$I_{\text{bus}} = K \cdot I_{\text{branch}} \quad (2)$$

$$I_{\text{bus}} = [I_{b2} \ I_{b3} \ \dots \ I_{bn}]^T \quad (3)$$

Where  $K$  is a non-singular square matrix of order  $N-1$  that  $N$  is total number of buses. In the matrix each row is describing the element incidences. A building algorithm for matrix  $K$  can be developed as follows:

- 1- The diagonal elements of matrix  $K$  are one (i.e. let  $K(j, j) = 1$ ) . The variable  $j$  is denoting the element number.
- 2- For each 'j'th element let  $m(j)$  is the set of element numbers connected at its receiving end.(i.e. let  $K(j, m(j)) = -1$ ).
- 3- All the remaining elements are zero. It can be observed that all the elements of matrix  $K$  below the main diagonal are zero.

After constructing matrix  $K$ ,at the first iteration transmission losses are initialized as zero for each element. From the bus powers specified the branch powers are determined as per following equation. The transmission loss is included as the difference between the sending end/receiving end powers.

$$S_{\text{bus}} = K \left[ S_{\text{branch}}^{\text{sending}} - TL_{\text{branch}} \right] \quad (4)$$

$$S_{\text{branch}} = K^{-1} \cdot S_{\text{bus}} + TL_{\text{branch}} \quad (5)$$

The bus voltage, branch current and bus current are determined from  $R_{ij}$  where the variable  $R_{ij}$  is determined for each element using (7).

$$S_{ij} = P_{ij} + iQ_{ij} = R_{ij} Y_{ij}^* \quad (6)$$

$$R_{ij} = S_{ij} Z_{ij}^* \quad (7)$$

Where  $S_{ij}$  is the complex power flowing from node  $i$  to node  $j$  and  $Z_{ij}$  is the impedance of element  $ij$ .

Thus the bus voltage , branch current are determined as follows :

$$V_j = V_i - \frac{R_{ij}^* I_{ij}}{V_i} \quad (8)$$

$$I_{ij} = \frac{R_{ij}^* Y_{ij}}{V_i} \quad (9)$$

Where  $V_j$  is the bus voltage at bus  $j$  ;  $V_i$  is the bus voltage at bus  $i$  and  $I_{ij}$  is the branch current flowing through element  $ij$ .

Since the transmission losses are neglected in the first iteration there will be mismatch between the specified powers and calculated powers. The mismatch is a part of the transmission loss.  $TL_{ij}^r$  is the transmission loss part for 'ij'th element for 'r'th iteration. Transmission loss of each element is the summation of the transmission loss portions of all previous iterations. Hence Active loss calculation for load flow is summarized as following equations :

$$S_{\text{branch}}^{\text{receiving}} = S_{\text{branch}}^{\text{sending}} - TL_{\text{loss}} \quad (10)$$

$$S_{ji} = S_{ij} - TL_{ij} \quad (11)$$

$$S_{ij} = \sum_{i \in K(i)} P_{ij} + iQ_{ij} = \sum_{i \in K(i)} V_i (V_i^* - V_j^*) Y_{ij}^* \quad (12)$$

Where  $k(i)$  is the set of nodes connected to node  $i$  , and  $P_i/Q_i$  denote the real/reactive power at node  $i$ .

$$TL_{ij} = \sum TL_{ij}^r \quad (13)$$

$$TL_{ij}^r = S_j^{\text{spec}} - {}^{(r-1)}V_j \cdot {}^{(r-1)}I_j^* \quad (14)$$

Where  $r$  is the iteration count. The convergence criteria is that the 'r'th iteration of the transmission loss part of each element should be less than the tolerance value of  $10^{-4}$  as shown in (15).

$$\max (TL_{ij}^r) \leq \epsilon \quad (15)$$

Thus the active power loss at all branches can be easily obtained from the following equation :

$$P_{\text{loss}} = \text{real}(TL_{ij}) \quad (16)$$

For system having less transmission loss the algorithm will perform faster.

The convergence of this algorithm is quite comparable with other schemes.

#### IV- distribution network reconfiguration approach using a tree model

From graph theory, a distribution network can be represented with a graph that contains a set of nodes  $N$  and a set of branches  $B$ . In this theory any graph that contains no cycles is an acyclic graph and a tree is a connected acyclic graph. In a tree any two vertices are connected by a path. If  $G$  is a tree then  $E=V-1$  that  $E$  is total number of branches and  $V$  is total number of nodes.

Therefore, the distribution network reconfiguration problem is to find a radial operating structure that minimizes the system power loss while satisfying radiality constraints, which ensures that the network topology operation should be radial.

In this paper for determining the nodes with no supply and loops, at first we introduced a matrix called node and branch incidence matrix and denoted by  $M$ . The elements of this matrix are constructed of 0,1. Row numbers of this matrix is equal to node numbers of system. Also column number of this matrix is equal to branch numbers of this system. This means that the branch related with  $n$ 'th bus is saved at  $m$ 'th column of matrix. In this matrix if any of nodes and branches are connected together, element is one, otherwise its element is zero. At the next stage we must determine fundamental network loops.

Fundamental loops based on a graph theory includes a set off all simple loops (simple loop means the smallest possible loop) and independent loops from each other (i.e. none of the loops is located in another loop). that in fact, the number of fundamental loops of the system is equal to the number of NO branches.

In this method for determining fundamental loops of the system after determining incidence matrix, in each level, a NO branch is added to system to form a new loop in system. Then nodes that connected with one branch (i.e. first order nodes) in the matrix are determined. If sum of elements of a row in the incidence matrix is one, these nodes have degree of one or called first order nodes. After determining first order nodes, branches connected to these nodes is removed. This process is repeated until no first order node remains in the system (i.e. there must be no difference in the condition of incidence matrix before, after removing all first order nodes). Finally the numbers of remaining nodes can be saved in a vector that this vector represents a fundamental loop.

After finding fundamental loops of system we must randomly choose a branch and open it. This random choice is done with random choosing numbers of fundamental loops vector's columns. Since some of the branches are common in some of fundamental system loops and it is possible final configuration have no condition of radiality and load connectivity, after generating of a configuration, radiality condition of network must be checked.

For finding nodes with no supply in the system, incidence matrix must be checked after opening a random branch at any fundamental loops. In this case we must open five branches (which is equal to numbers of fundamental system loops). A zero row in incidence matrix shows that there is a node with no supply in the system. So, this configuration isn't accepted.

Also for study of radiality condition of system we must remove the branches connected to nodes with degree of one (i.e. rows of incidence matrix that sum of their elements is one). This process is repeated until incidence matrix doesn't differ from its previous condition (i.e. no first order node remain). If incidence matrix of system is equal to zero matrix this configuration is accepted. This process shown in fig.2. After determining trees of graph with this method we must run a load flow on accepted configuration with respect to network radiality conditions and also, fitness function that is loss reduction of 33-bus test system must be minimized with optimization methods such as genetic algorithm.

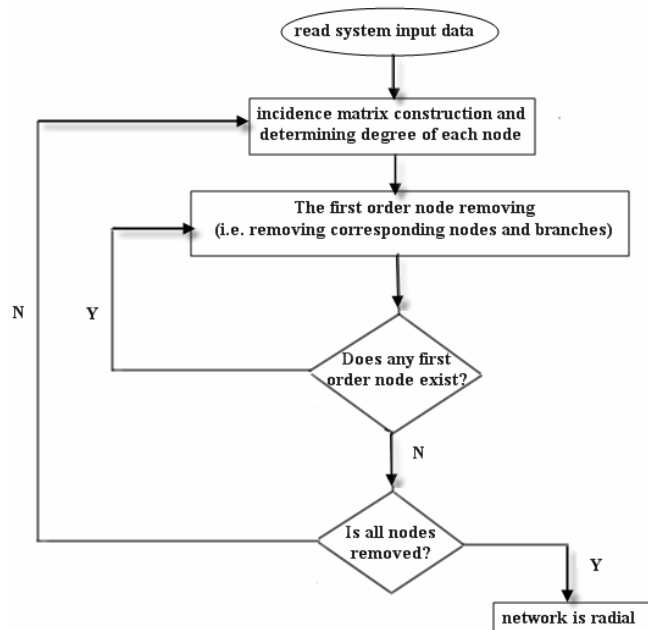

Fig. 2 Flowchart for network radiality examination with graph theory

Genetic algorithm is a probabilistic search method for solving optimization problems. Holland [9] first made pioneering contributions to the development of GAs that can be effectively adopted for complex combinatorial problems. GAs provide a solution to a problem by working with a population of individuals each representing a possible solution. Each possible solution is termed a 'chromosome'. New points of the search space are generated through GA operations, known as reproduction, crossover and mutation. These operations consistently produce fitter offsprings through successive generations, which rapidly lead the search towards global optima. In fact, a GA is one of the meta heuristic methods trying to imitate the biological phenomenon of evolutionary production through the parent-children relationship.

In previous methods, the string used in GA describes all the switch positions and their 'on/off' states. The string can be very long and it grows in proportion with the number of switches. For large distribution systems, such long strings can't be effectively searched by GA. In this paper, the string will be shortened. Also for chromosome encoding we considered a string that number of its codes is equal to the fundamental network loops and in this case its numbers equals to five.

Thus after choosing a branch of each loop, each branch is inserted into one of string locations and in fact each code is

the location of one branch of its corresponding loop. After examining the radiality constraints of network, the target code is inserted in the algorithm cycle as shown in fig.3 .

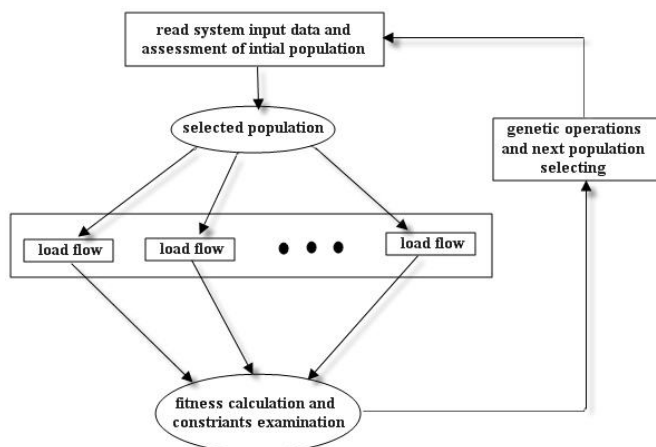

Fig. 3 Flowchart of the genetic algorithm cycle for loss minimization

As illustrated in the fig.3. in the first step we defined a function for initial population selection respect to the received data from network. In this function for constructing the chosen chromosome after diagnosis of system loops, their numbers is saved in specific vectors and a random value is chosen from the column number of each vector with respect to the length of each vector. Then the branch corresponding to that column is opened and inserted in to one of target string locations.

Then we considered the two constraints related to network radiality conditions. If those conditions varnishes, we consider the cost of loss function equal to infinite and the chromosome isn't acceptable and initial population is chosen once more, otherwise the load flow program is executed and the fitness function value is calculated. In this paper stopping criteria considered to be 100 generations. The initial population was 20 generations and its initial range was equal to the number of the biggest system loop (loop 5) that was constructed 21 branches.

For effective comparison, the results of the proposed method with applying two load flow method along with other methods are shown in table VII. The power loss with this method and using Newton\_Raphson load flow before reconfiguration is 211 kW and after reconfiguration is 151 kW and reduction in power loss is 60 kW which is approximately 28.44 %.

But with using radial distribution power flow in Complex mode it can be concluded that the results is better than other methods since from the results it is observed that the power loss before reconfiguration is 194 kW and after reconfiguration is 75.5 kW and reduction in power loss is 118.5 kW which is approximately 61.08 %. Thus the saving in total loss by the proposed method is higher than the other methods and Final open switches in this method are {2,10,8,36,25}.

## V. CONCLUSION

In this paper a new heuristic approach for reconfiguration problem is implemented by PSAT software which that, decision of which switch is to be closed is based on the voltage difference across NO switch. NO switch across which, maximum difference occurs is selected for closing and also decision of which branch to be opened to make a system radial is based on a new heuristic search methodology for determining the minimum loss configuration of a radial distribution system which is discussed in the section II. From the results it is observed that The number of all load flow runs required for the entire process is 26 whereas it is 29 in case of Baran and Wu and with this method the saving in total loss is higher than the proposed method by Kashem [8] and also CPU time needed compared with other methods is very less. Load flow analysis is an integral part of the distribution system reconfiguration. In this paper in order to get the precise branch current and system power loss, a radiation distribution network load flow method in section III is presented.

Since distribution systems contains many nodes and branches (and switches), and the total number of trees is extremely large. In the section IV a simple and efficient technique by graph theory is described to detect the loops formed during reconfiguration process. With this method to reconfigure the system, it is necessary to obtain the tree structure of a particular radial distribution system. This tree formulation indeed identifies the connectivity of the nodes and branches and formation of the loop because it is necessary to maintain a radiality of system for better protection. The refined genetic algorithm is also set up, in which some improvements are made on chromosome coding. As a result, premature convergence is avoided. The proposed approach is tested on 33-bus distribution networks, showing excellent results and computational efficiency. For effective comparison, the results of the proposed method along with a number of approaches available in the technical literature are shown in Table VII. From this table it can be concluded that this technique represents an improved, more efficient method which can easily solve the distribution network reconfiguration problem compared with other methods.

TABLE VII -COMPARISON PROPOSED METHOD WITH OTHER METHODS USING 33-BUS DATA

Method	Final open switches	Total loss savings (%)
Kashem[8]	{7,14,11,32,28}	26.14
Heuristic method [7]	{33,14,8,32,28}	27.13
Proposed method with graph theory and using Newton_Raphson load flow method	{36,25,21,9,7}	28.44
Proposed method with graph theory and using complex distribution load flow	{2,10,8,36,25}	61.08

APPENDIX

Figs a and b show system configuration for a 33-bus distribution test system , before and after reconfiguration , respectively .

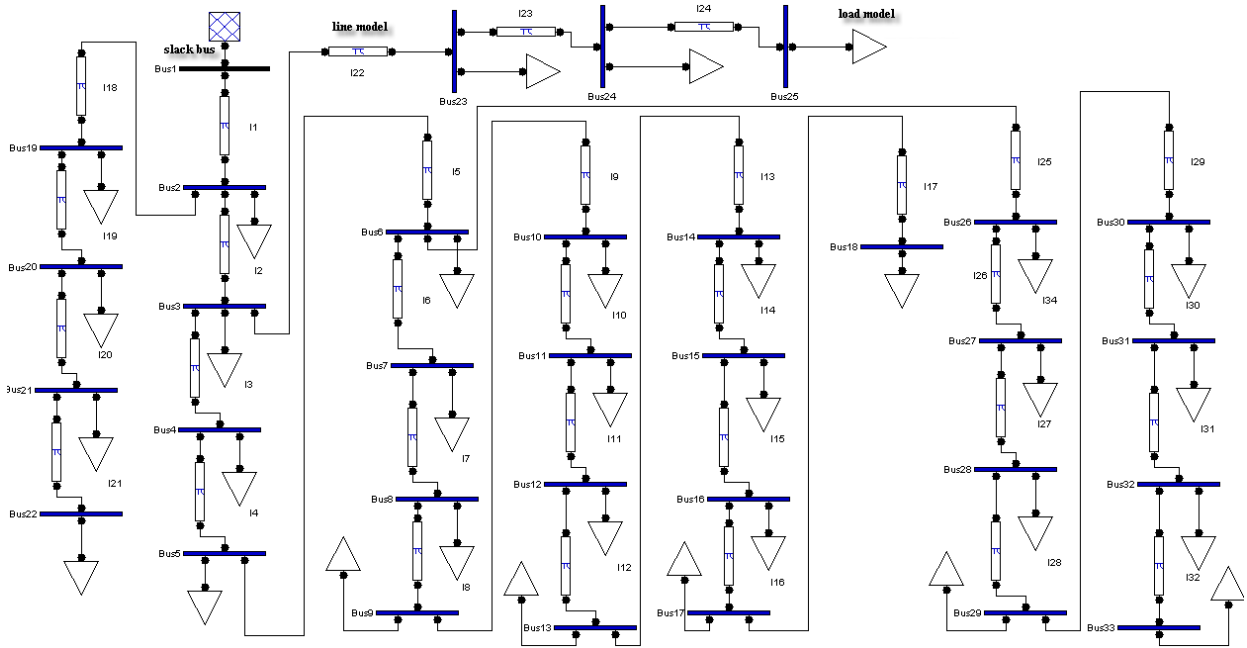

Fig.a simulation result for 33-bus test system with PSAT program (before reconfiguration)

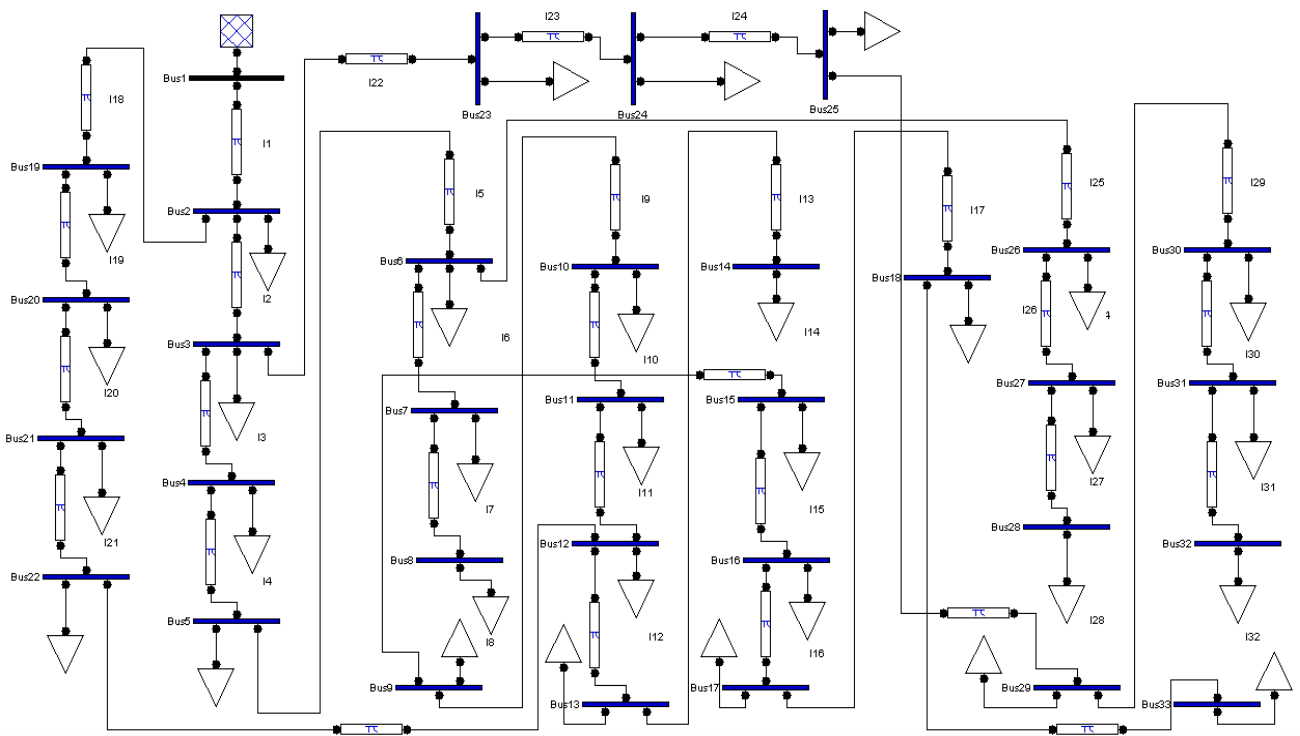

Fig. b simulation result for 33-bus test system with PSAT program (after reconfiguration)

REFERENCES

- [1] A. Merlin, H. Back, "Search for a minimal-loss operating spanning tree configuration in an urban power distribution system" Proceedings of 5th Power System Computation Conference (PSCC), Cambridge, UK, (1975), pp. 1-18.
- [2] M.E.Baran, F.F.Wu, Network reconfiguration in distribution systems for loss reduction and load balancing, IEEE Trans. Power Delivery 4 (2) (1989) 1401-1407.
- [3] J.-Fan, L.Zhang, J.D.McDonald, Distribution network reconfiguration: single loop optimization, IEEE Trans. Power Syst. 2 (3) (1996).
- [4] H.D. Chiang, R.J. Jumeau, Optimal network reconfiguration in distribution systems, part 1: a new formulation and a solution methodology, IEEE Trans. Power Deliv. 5 (4) (1990) 1902-1909.
- [5] K. Nara, A. Shiose, M. Kitagawa, T. Ishihara, Implementation of genetic algorithm for distribution system loss minimum reconfiguration, IEEE Trans. Power Systems 7 (3) (1992) 1044-1051.
- [6] S.K.Goswami, S.K.Basu, A new algorithm for the reconfiguration of distribution feeders for loss minimization, IEEE Trans On Power Delivery, Vol 7, No 3, July 1992.
- [7] R. Srinivasa Rao, S. V. L. Narasimham, A New Heuristic Approach for Optimal Network Reconfiguration in Distribution Systems, International Journal of Applied Science, Engineering and Technology 5(1) (2009).
- [8] M. A. Kashem, V. Ganapathy, G.B. Jasmon, and M. I. Buhari, "A Novel model for loss minimization in distribution networks", IEEE International Power Technologies 2000 Conference on Electric Utility deregulation, restructuring at City University London, 4-7 April 2000, pp. 251-256.
- [9] Holland JH. Adaptation in natural and artificial systems. Michigan: University of Michigan Press; 1975.
- [10] RM Saloman Danaraj, Shankarappa F Kodad and Tulsi Ram Das, "An algorithm for radial distribution power flow in Complex mode including voltage controlled buses", Indian Journal of Science and Technology, Vol.1 No.2 (Dec. 2007).