

Fuzzy Boundary Layer Solution to Nonlinear Hydraulic Position Control Problem

Mustafa Resa Becan

Abstract— Sliding mode control with a fuzzy boundary layer is presented to hydraulic position control problem in this paper. A nonlinear hydraulic servomechanism which has an asymmetric cylinder is modeled and simulated first, then the proposed control scheme is applied to this model versus the conventional sliding mode control. Simulation results proved that the chattering free position control is achieved by tuning the fuzzy scaling factors properly.

Keywords— Hydraulic Servomechanism, Position Control, Sliding Mode Control, Chattering, Fuzzy Boundary Layer

I. INTRODUCTION

HYDRAULIC servomechanisms are important actuators in modern industry, since they have a high power ratio, fast response and high stiffness. Therefore, researching the position or force control of hydraulic systems should be of great interest to both the academic and industrial fields. The hydraulic servomechanisms have some nonlinearities due to the the friction sources and the flow equations. Variable structure based sliding mode controller is well suited to nonlinear systems and offers considerable advantages, in particular the property of robustness to model parameter uncertainty [1]. Recently, the important studies have been addressed to sliding mode control applications in hydraulic servo systems. Chuang and Shiu, successfully simulated the analog integral variable structure control on a electrohydraulic servo [2]. Moreover, some other investigations have been devoted to hydarulic systems by performing the sliding mode control [3-5]. However, several drawbacks limit the application of this method in practice. The undesirable chattering effect arises due to the high switching frequency when the system operates in the sliding mode. In this study, a hydraulic servo model [6] was simulated and sliding mode control was applied to this model by introducing a fuzzy boundary layer to reduce the chattering effect.

II. MATHEMATICAL MODEL OF HYDRAULIC SERVOMECHANISM

The dynamical equation of hydraulic servomechanism which drives the mass m (Fig.1) is

$$m\ddot{y} + B\dot{y} + F = P_1A_1 - P_2A_2 \quad (1)$$

Mustafa Resa Becan is with the Istanbul Technical University, Turkey. (e-mail: becanm@itu.edu.tr).

where P_1, P_2 are the pressures at the cylinder chambers, A_1, A_2 the piston areas, F is the friction force and y is the displacement.

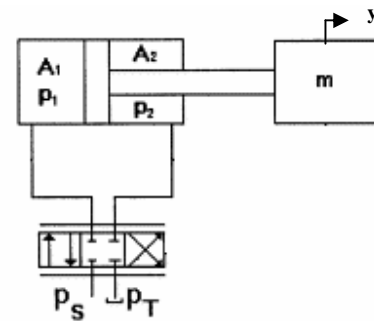

Fig.1 Hydraulic Servomechanism

If the state variables are appointed as $X_1 = y$ $X_2 = \dot{y}$ $X_3 = P_1$ $X_4 = P_2$, the state equations can be obtained as seen below.

$$\begin{aligned} \dot{X}_1 &= X_2 \\ \dot{X}_2 &= (X_3A_1 - X_4A_2 - BX_2 - F) / m \\ \dot{X}_3 &= \frac{\beta}{A_1X_1}(Q_1 - A_1X_2) \\ \dot{X}_4 &= \frac{\beta}{A_2(L - X_1)}(A_2X_2 - Q_2) \end{aligned} \quad (2)$$

where β is the fluid bulk modulus, L is the total cylinder stroke, Q_1 and Q_2 are the flow rates at the cylinder chambers which includes the valve control signal u , to provide a precise position control.

III. SLIDING MODE CONTROL

Consider the following nonlinear system

$$\dot{x} = f(x,t) + B(x,t)u \quad (3)$$

where $X \in R^n$ is the state variables of dimension n , $u \in R^m$ is the control variable, $f(x,t)$ and $B(x,t)$ are the nonlinear dynamics of the system. If x_d denotes the reference trajectory, then the error between the reference and measured system

output can be defined as $e=x_d-x$. Let $s=0$ denote the sliding surface in the state space of the error. The purpose of the sliding mode control is to force error vector e approach to the sliding surface and then move along the the sliding surface to the origin. Therefore, it is required that the sliding surface is stable, then the error will die out asymptotically. The discontinuous structure of a sliding mode controller is

$$u = \varepsilon \operatorname{sgn}(s) \quad (4)$$

where s the switching function because the control action switches its sign on the two sides of the switching surface $s=0$, ε is the control gain. s , can be defined as:

$$s = \dot{e} + \lambda e \quad (5)$$

where \dot{e} is the first derivative of error and λ is a constant. $\operatorname{sgn}(s)$ is the sign function defined as:

$$\operatorname{sgn}(s) = \begin{cases} -1 & \text{if } s < 0 \\ 1 & \text{if } s > 0 \end{cases} \quad (6)$$

As well known, the control strategy must satisfy the sliding condition $s\dot{s} < 0$ [1]. If this method is adapted to hydraulic position control problem the error term should be written as

$$e = y_{desired} - y_{actual} \quad (7)$$

then the switching function can be obtained depending on the expression of (7).

Using a sign function often results in chattering phenomenon in practice due to the high frequency switching near the sliding surface. This side effect should be avoided in the applications, therefore a boundary layer around the switching surface is introduced to solve the chattering problem.

$$u = \varepsilon \operatorname{sat}\left(\frac{s}{\phi}\right) \quad (8)$$

where ϕ is the thickness of the boundary layer. $\operatorname{sat}\left(\frac{s}{\phi}\right)$ is a saturation function which is defined as:

$$\operatorname{sat}\left(\frac{s}{\phi}\right) = \begin{cases} \frac{s}{\phi} & \text{if } \left|\frac{s}{\phi}\right| \leq 1 \\ \operatorname{sgn}\left(\frac{s}{\phi}\right) & \text{if } \left|\frac{s}{\phi}\right| > 1 \end{cases} \quad (9)$$

IV. FUZZY BOUNDARY LAYER TO CHATTERING PROBLEM

The introduction of the boundary layer around the switching surfaces reduces chattering at the cost of increased tracking error. The variable boundary layer is a popular solution to this problem. In this paper, the fuzzy boundary layer is proposed in order to improve the performance of the sliding mode controller (Fig.2). This leads a strategy to adjust the thickness

of the boundary automatically and this fuzzy system adopts the sliding surface s as input and the thickness ϕ of boundary layer as output. The normalized membership functions for input s and output ϕ are illustrated in Fig.3.

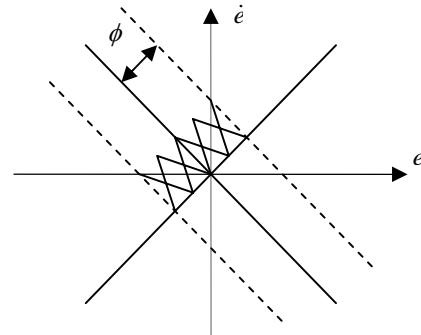

Fig. 2 Fuzzy Boundary Layer

The knowledge base provides the membership functions and rule base, but the former experiments were also used [7]. The single input-single output rule base is presented below:

IF s is NE THEN ϕ is NE

IF s is ME THEN ϕ is ME

IF s is ZE THEN ϕ is ZE

IF s is PO THEN ϕ is PO

Where NE: Negative, ME: Medium, ZE: Zero, SM: Small, PO: Positive.

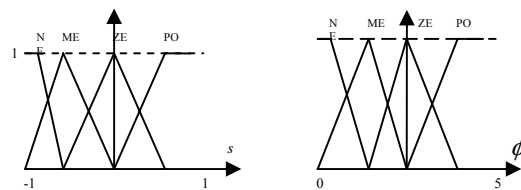

Fig. 3 The membership functions for s, ϕ

V. SIMULATION RESULTS

The mathematical model of hydraulic servomechanism was simulated by applying conventional and fuzzy sliding mode control respectively. 40/20 mm asymmetric hydraulic cylinder was used which drives a load $m = 50\text{kg}$ with total stroke $L = 1\text{m}$. The other parameters were chosen as $\beta = 1.4 \cdot 10^9 \text{N/m}^2$, supply pressure $P_s = 75 \text{bar}$, desired position $y_d = 0.5\text{m}$.

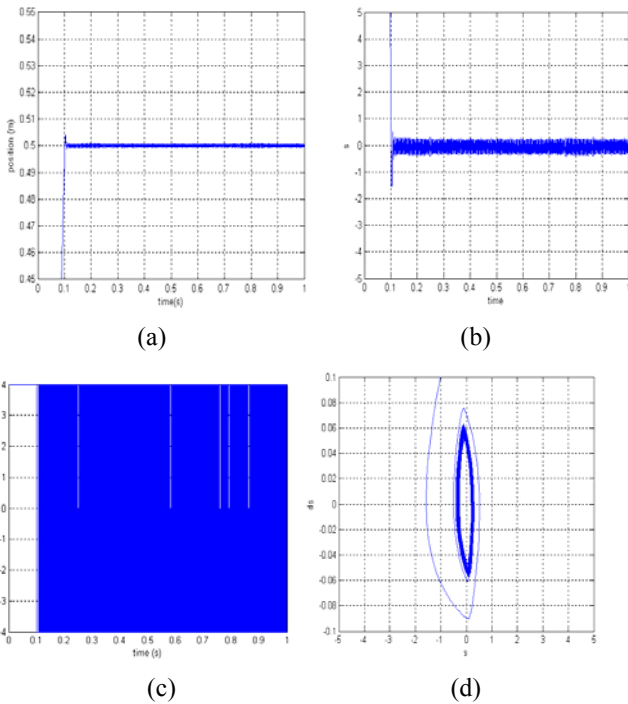

Fig. 4 The Results for Conventional Sliding Mode Control
 a) Cylinder Position b) s function c) Control signal
 d) Switching Surface

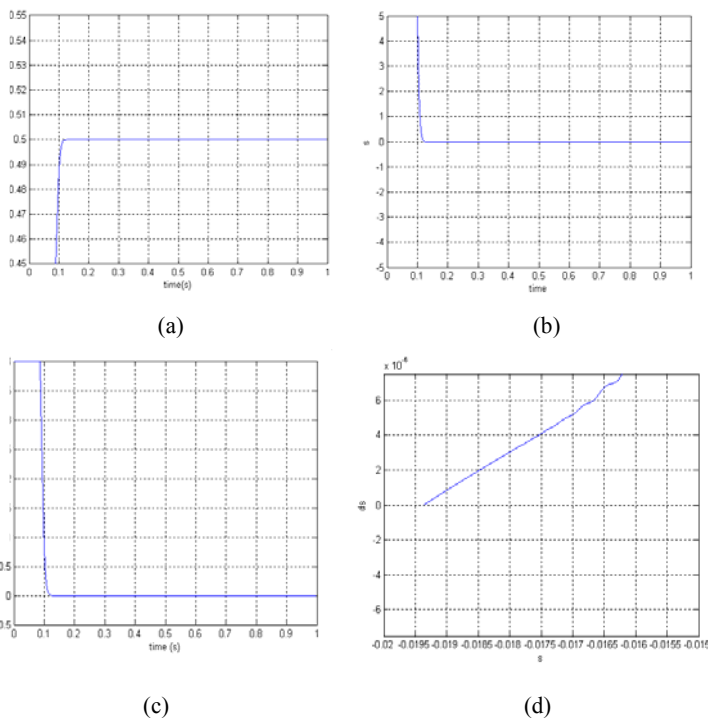

Fig. 5 The Results for Fuzzy Sliding Mode Control
 a) Cylinder Position b) s function c) Control signal
 d) Switching Surface

The gain of discontinuous term in sliding mode control was determined as $\varepsilon = 4$. Initial conditions are $y(0)=0.1m$,

$\dot{y}(0) = 0$, $P_1(0) = 32bar$ and $P_2(0) = 43bar$. The simulation results for conventional SMC are exhibited in Fig.4. The piston position, s function, control signal and the phase plane as the switching surface are the performance criteria were chosen. The desired position is reached in 0.12 s, but the chattering phenomonia does obviously exist at the system responses as seen on the figures. The results with the fuzzy boundary layer are presented in Fig. 5.

The scaling factors were determined by using the trial and error method to obtain the optimal solution as $K_\phi = 10$ and $K_s = 0.0001$. The results depend on these tuned parameters show that the fuzzy boundary layer achieve to filter the chattering completely on the switching surface in approximately 0.12 s. This reach time is the same as previous application.

VI. CONCLUSION

A nonlinear hydraulic position control system was modeled and simulated in this study. After the conventional sliding mode control application, a fuzzy boundary layer was proposed to avoid the chattering effect and the simulation results showed that if the fuzzy parameters are optimized conveniently, the chattering phenomonia can be fully filtered by obtaining an accurate position control without any time delay. Surely, some other fuzzy sliding mode control and some modern optimization techniques such as genetic algorithms can be developed to tune the fuzzy control parameters precisely for the future studies in hydraulic position control area.

REFERENCES

- [1] Utkin V.I, "Variable Structure Systems with Sliding Modes" IEEE Transactions on Automatic Control" AC-22, 2 (1977), 212-222
- [2] Chuang and Shiu, "CPLD based DIVSC of hydraulic position control systems" Computers&Electrical Engineering, Volume 30, Issue 7, October 2004, 527-541
- [3] Bonchis, Corke, Rye and Ha, "Variable Structure Methods in Hydraulic Servo Systems Control" Automatica, Volume 37, Issue 4, April 2001, 589- 595
- [4] Fung and Yang, "Application of VSC in position control of a nonlinear electrohydraulic servo system" Computers&Structure, Volume 66, Issue 4, February 1998, 365-372
- [5] Fung, Wang, Yang and Huang, "A variable structure control with proportional and integral compensations for electrohydraulic position servo control system" Mechatronics, Volume 7, Issue 1, February 1997, 67-81
- [6] Becan, Kuzucu and Kutlu, "A realistic simulation of the hydraulic position control systems" Tr.Journal of Engineering and Environmental Sciences, Volume 22, 1998, 125-130
- [7] Lee, Kim, Kang and Park, "A new sliding mode control with fuzzy boundary layer", Fuzzy Sets and Systems, Vol. 120, 2001, pp.135-143