

Implementation and Simulation of Half-Bridge Series Resonant Inverter in Zero Voltage Switching

Buket Turan Azizoğlu

Abstract—In switch mode power inverters, small sized inverters can be obtained by increasing the switching frequency. Switching frequency increment causes high driver losses. Also, high $\frac{di}{dt}$ and $\frac{dv}{dt}$ produced by the switching action creates high Electromagnetic Interference (EMI) and Radio Frequency Interference (RFI). In this paper, a series half bridge series resonant inverter circuit is simulated and evaluated practically to demonstrate the turn-on and turn-off conditions during zero or close to zero voltage switching. Also, the reverse recovery current effects of the body diode of the MOSFETs were investigated by operating above and below resonant frequency.

Keywords—Driver losses, Half Bridge series resonant inverter, Zero Voltage Switching

I. INTRODUCTION

SWITCHING is divided into two groups; hard switching techniques and soft switching techniques. In hard switching techniques, power density is low, size and cost of the circuit is high. Beside these disadvantages, during switching transitions current and voltages overlap and cause EMI and RFI. In some type of inverter topologies, in order to minimize the switching losses, improve the efficiency, reducing the current/voltage stresses and the difficulty of implementation, the voltage across the switch can be achieved by soft switching techniques such as zero or close to zero during turn-on and turn-off conditions [1], [2], [3], [6], [9]. Generally, Zero Voltage Switching (ZVS) is more appropriate than Zero Current Switching (ZCS) at high switching frequencies since the internal capacitance of the switch is discharged if the switch has a finite voltage at turn on. This charge gets out as heat during turn on. This loss becomes serious at very high switching frequencies [1], [7]. Furthermore ZVS reduces the switching noise noticeably.

N Channel MOSFETs are favor in power electronic converter circuits. In N Channel MOSFETs mobility of electrons is faster than holes, thus higher carrier mobility of electrons reduces the on state losses were presented in [8].

In most research, the losses of converters are generally investigated by emphasizing the effects of the parasitic elements [16, 17] and new converter designs with proposed

ZVS to reduce losses above resonant frequency [18]. In [19], an analytical loss model of a power MOSFET with a current source resonant driver is developed and the total loss is observed and compared with different switching frequencies between the resonant driver and conventional driver. In [20], the parasitic effects of MOSFET drain-source voltage oscillations depending on the drain source capacitance are investigated but MOSFET body diode is ignored. In this paper, a half bridge zero voltage switching series resonant inverter by using N Channel modern MOSFETs was simulated and compared with the experimentally taken plot graphs. Design considerations and reverse recovery effect of the MOSFET body diode below and above the resonant frequency is analyzed. Drain source voltage oscillations due to the MOSFET body diodes are emphasized. Simulations were made by using ORCAD 9.1 software.

II. OPERATION PRINCIPLE OF SERIES RESONANT INVERTER

Implementation of a boost converter circuit is shown in Fig 1. In the circuit IR2113 was utilized as MOSFET DRIVER, CD4069 was used as LOGIC INVERTER, SK3131 N Channel MOSFETs were used as switching elements. The switching frequency of the circuit is selected as 124 kHz. SPICE Simulation program is used to simulate the circuit.

In order to drive the circuit in resonant frequency the magnitudes of the inductance, resistor and capacitor that form the series circuit are chosen by the resonant frequency equation in order to set the imaginary part to be zero. Then,

resonant frequency is equal to
$$w = \sqrt{\frac{1}{LC} - \frac{R^2}{L^2}}$$
.

Series resonant frequency is calculated to 106.8 kHz. Other parameters for the series converter are:

Inductor: 5 μ H

Capacitor: 440nF

Resistor: 0.3 Ω

Mosfet failures play an important role in ZVS circuits such as low reverse recovery of the intrinsic body diode, $C \frac{dv}{dt}$ shoot-through current proposed in [4], [5]. To overcome these failures, fast reverse recovery of body diode is needed especially at lower reverse voltage. The current flowing through the body diode is essentially crucial when the MOSFET is turned-off. At this point SK3131 power MOSFET

Buket Turan Azizoğlu is with Electrical & Electronic Engineering Faculty, Dokuz Eylül University, İzmir, Turkey (phone: 0090 232 4127694, email: buket.turan@deu.edu.tr)

with high speed freewheeling body diode is used. There is another point to take into consideration; series resonant converter is preferred to operate in a value higher than the resonant frequency to reduce the losses caused by the energies during the charging and discharging states of the capacities in the MOSFET's structure in turn-on condition [11].

the gate drain capacitance C_{gd} with the potential across its terminal and is called "miller". Miller effects the negative feedback from input to output and increases the apparent input capacitances refer to (3). This increment is quite large so as the gate-to-source voltage increases very slowly as told by Kazimierczuk in [12]:

$$C_{miller} = C_{gd}[1 - A_v] \quad (1)$$

$$A_v = \frac{\Delta V_{ds}}{\Delta V_{gs}} \quad (2)$$

$$C_{input} = C_{gs} + C_{miller} \quad (3)$$

In miller plateau level, drain current is constant and nearly equals to load current and V_{gs} is constant too, hence gate current is discharged through the gate-drain capacitance with rate of $C_{gd} \frac{dV_{ds}}{dt}$ [13]. Due to the increase of the apparent value of the C_{gd} on account of the miller effect, rate of the discharging of the gate current is small. In order to reduce the Miller Effect, MOSFET must be turned on or off when its V_{ds} reaches zero or close to zero. Energy storage of the capacitances does not occur during zero voltage switching. Zero voltage is obtained by the resonant circuit. At zero voltage switching current is already flowing through the MOSFET body diode.

Resistors connected to the input of the gates of the MOSFETs are 20Ω , which is enough to prevent the ringing and not as much as to reduce the switching speed.

CD4069 logic inverters all of which having six logic inverters are used in this circuit. Input signal is a square wave changing from zero volt to 15V. Because of the diodes in the internal structure of the logic inverter, the pulse voltage varies between $(0 - V_{diode \text{ forward voltage}})$ and $(15V + V_{diode \text{ forward voltage}})$, the purpose of the $1k\Omega$ resistor connected to the input signal, is to clamp the diode forward voltage drop.

Pulse should reach at least "Input High Voltage" level for transition of logic inverter from off to on state, so as to obtain high voltage at the output and the time elapsed to reach this level is called delay time. Likewise, pulse should not exceed "Input Low Voltage" level for transition of logic inverter from on to off state and the time needed to reach this level is equal to the delay time too. Time delay from on to off state does not occur when 2N2222 transistors in the circuit of Fig.1 are used. Due to the high voltage applied to the base of the transistor, it will be turn-on and acts as a closed switch, by this means output of the logic inverter is abruptly withdrawn to zero. As a consequence this, underlap switching is created.

In the driver stage, bootstrap circuit is used to supply power to drive the high side N-Channel MOSFET. It is charged when the lower side MOSFET is turned on and the output pin is below the supply voltage. Bootstrap capacitor has to charge up very quickly thus, diode used in bootstrap circuit should be

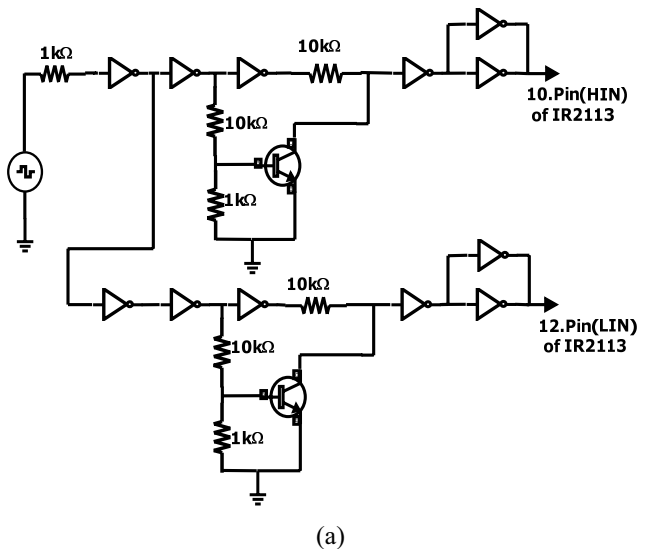

(a)

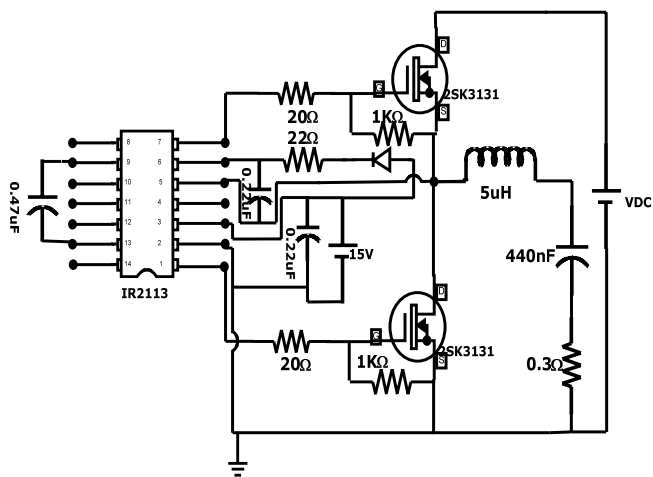

(b)

Fig 1 Schematic of the Prototype Circuit a) driving signal shaping circuit b) driver and power stage

Voltage of the drain-source terminals of the MOSFET depends on $R_{ds(on)}$ resistor's value. If the resistor $R_{ds(on)}$ has a small value, the voltage of the drain source terminal is also low. Hence, $R_{ds(on)}$ determines the power loss in the on state. SK3131 MOSFET's $R_{ds(on)}$ value is as low as 0.085Ω and this is one of the reasons of this MOSFET to use in this circuit. Moreover, intrinsic capacitances of the MOSFET are important for the switching action. Charging and discharging of the intrinsic capacitances of a MOSFET determines the switching response time. Equation (1) shows the variation of

schottky rectifier diode which has very small reverse recovery. MBR7545 schottky rectifier diode is used in this circuit. When the low side MOSFET turn-off, the voltage of the bootstrap capacitor come up to the supply voltage level thus voltage for driving the high side MOSFET is obtained. On the other hand, bootstrap capacitor is discharged only when the high side MOSFET is turn on. The negative voltage occurs at the source of the switching device during turn off causes load current to suddenly flow in the low side freewheeling diode. The inductive parasitic elements, turn-off speed, di/dt of the MOSFET and gate-source capacitance and miller capacitance effect the generation of the negative voltage [14].

III. SIMULATION AND EXPERIMENTAL RESULTS

In the Fig 2 driving signals of the upper and lower side MOSFETs simulation and experimental results are shown While MOSFET on the upper side was passing from turn-on to turn-off, lower side MOSFET was enabled to stay in turn-on for approximately $0.5\mu s$ by giving delay time. This is called underlap switching. The reason is necessity to prevent shoot-through current and short circuit of the upper and lower switches. If both MOSFETs were in the on state, failures would occur in the circuit due to short term excessive current.

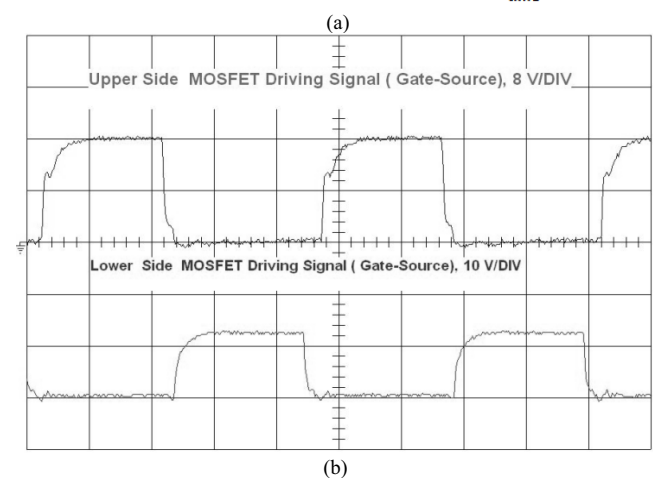
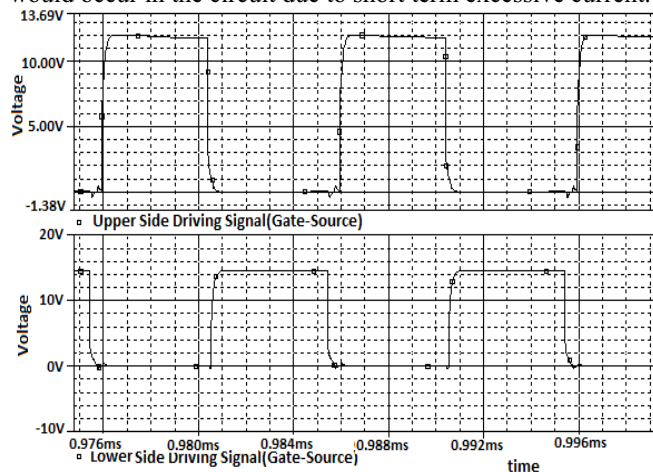

Fig. 2 (a) Simulation results of the MOSFETs driving signal (b) Experimental results of MOSFETs driving signal, $2\mu s$ (time/DIV)

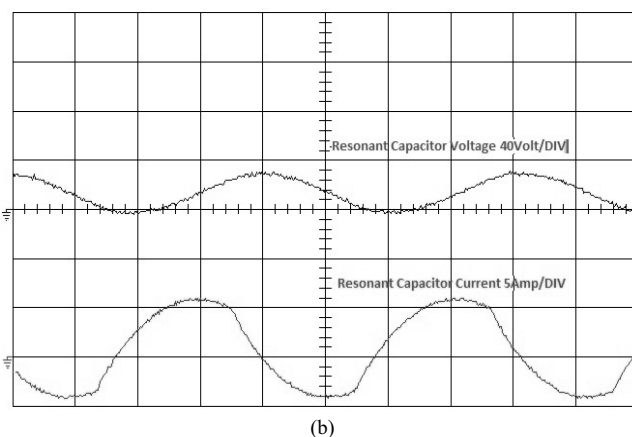
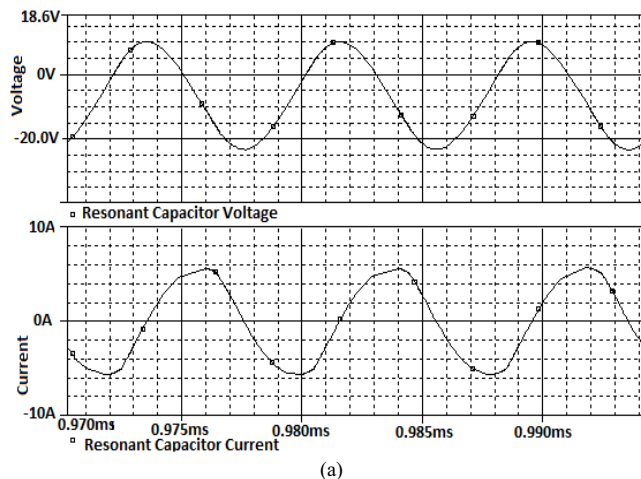
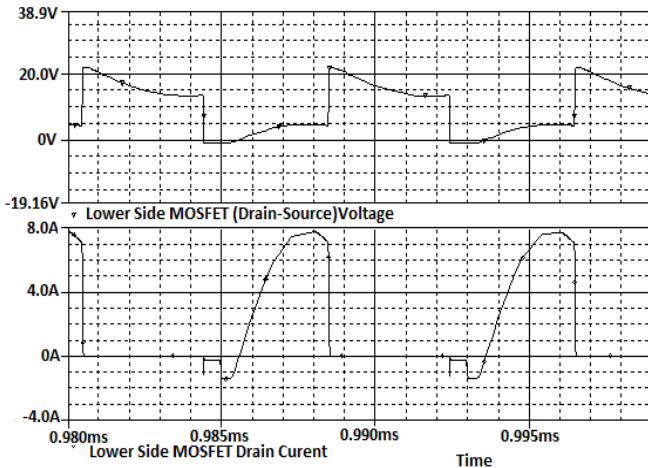

Fig. 3 (a) Simulation results of Resonant Capacitor Current and Voltage (b) Experimental results of Resonant Capacitor Current and Voltage, $2\mu s$ (time/DIV)

Current and voltage of the resonant capacitor is shown in the Fig 3. During the change in the status of the switches, the current flowing through the series resonant circuit is forced to change the direction. There is an inductor in the series resonance circuit. Due to the characteristic properties of the inductor, current flowing through it cannot change its direction suddenly. It must be zero before flowing in the reverse direction. Hence, the change in current path is obtained by the capacitor in the series leg of the resonant circuit. Instantaneous changes effect the magnitude of the capacitors current for series resonant inverter. Current lags voltage when the operating frequency is above resonance frequency, since zero transition of the voltage waveform occurs before the current waveform.

In current waveform measurements, P6022 current viewer device which was commercially available was used. Inserting a conductor into the probe causes additional impedance to the circuit that is measured. Since this device is a current transformer based that contains U-Shaped Core, L/R exponential decay arises out of the probe inductance loading the source impedance [15]. Based on the characteristic properties of the current probe, its output is inherently does

not give any information on the measured current's DC value thus the current waveforms have been shifted upward or downward in Fig 3.b, Fig 4.b and Fig 5 .b to any level for the best viewing purpose along with the other. Also, the current of the lower side MOSFET shown in Fig. 4.a and Fig. 5.a is the twice of the exact simulation results to see the details clearly.



(a)

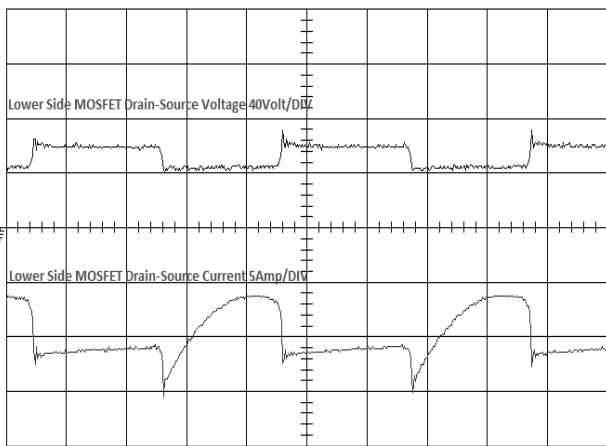

(b)

Fig. 4 (a) Simulation results of lower side MOSFET Drain-Source voltage and current above resonant frequency (b) Experimental results of lower side MOSFET Drain-Source voltage and current above resonant frequency, 2µs (time/DIV)

In the Fig 4 lower side MOSFET drain-source voltage and current are shown. In the OFF State the Drain Source voltage of the lower side MOSFET is almost equal to the DC source voltage. Transition of the lower MOSFETs from off state to the on state a low magnitude current spike is seen due to the reverse recovery of the MOSFET's body diode. Average of the current of the lower MOSFET is equal to zero; at this time current flows through the resonant circuit and upper MOSFET. On the other hand, when the lower side MOSFET is ON, current flows through the drain of lower side MOSFET.

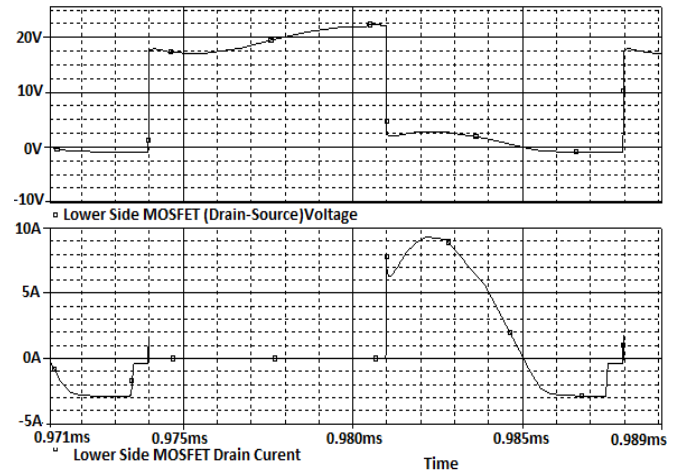

(a)

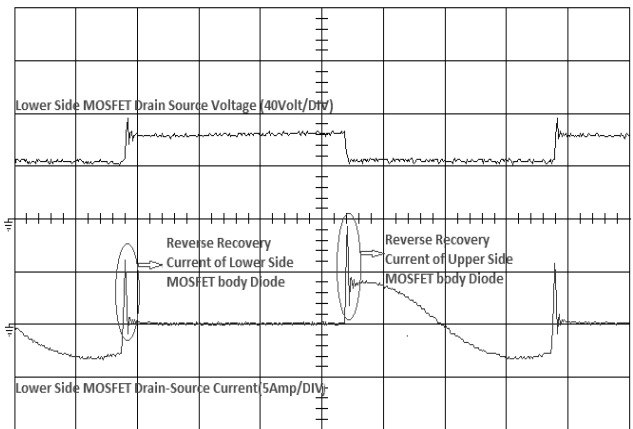

Fig. 5 (a) Simulation results of lower side MOSFET Drain-Source voltage and current (b) Experimental results of lower side MOSFET Drain-Source voltage and current below resonant frequency

Simulation and experimental results of Lower Side MOSFET Drain-Source voltage and currents below resonant frequency is shown in Fig.5. The operating frequency was equal to 70.3 kHz. When the circuit is in steady state and upper side MOSFET is in the OFF state, the current is flowing through the resonant circuit and lower side MOSFET. By the change of the direction of the resonant inductor current due to resonant effect, current begins to flow through the lower side MOSFET body diode and the lower side MOSFET turns off inherently. After a little time upper side MOSFET is triggered and turns on. The inductor current transfers to upper side MOSFET since it provides a higher voltage to feed to the resonant leg. Again the inductor currents direction is changed and the current begins to flow through the body diode of the upper side MOSFET (Note that the switching frequency is lower than the resonant frequency in that case). After triggering the Lower side MOSFET, current begins to flow through the lower side MOSFET and reverse recovery current of the upper side MOSFET body diode occurs due to instant

reversal of the conducting upper MOSFET body diode voltage.

IV. CONCLUSION

Zero Voltage Switching Resonant Inverters become more common at high frequencies to overcome high switching losses, shoot through currents and reverse recovery failures. Another important advantage is the reduction of EMI and RFI during switching because of the preventing the high di/dt and dv/dt . In this work ZVS series resonant inverter circuit has been analyzed by simulation and implementation. It is seen that simulation and experimental results are almost compatible.

There is a small time interval in which the MOSFET behaves as an active element of the circuit, during the transition to turn on- turn off or turn off- turn on. Failures in driving the MOSFET gate decrease in bandwidth and oscillations may occur because of the miller effect. This effect is diminished by reason of the quick charge of the internal capacitances of MOSFET. Rate of the increment of the current and voltage is reduced during switching; this is obtained by switching at zero or close to zero voltage. Furthermore, drain source voltage value is decreased to the low on-state value, which is small in this circuit due to the $R_{ds(on)}$ value.

MOSFET body diodes provide the closed current path during dead time. Dead time prevents failures caused by simultaneous conduction of totem-pole connected power switches. And also, dead time is used to fully charge or discharge the MOSFETs drain source capacitances used for zero voltage switching.

The simulations and experimental results show that, beside the most appropriate components especially fast body-drain diodes of the MOSFETs used, the operating frequency is an important parameter to reduce the losses. During the turn on transitions of the MOSFETs, switching losses occurs due to the reverse recovery of the MOSFET body diodes. The oscillations resultants of the reverse recovery of the MOSFET's body diodes have high frequencies which causes electromagnetic Interference. Electromagnetic Interference effects due to the oscillations with 3D Electromagnetic simulation program are planned as future work.

REFERENCES

- [1] N. Mohan, T. M. Undeland, W.P. Robbins, "Power Electronics: Converters, Application, and Design", John Willey & Sons, 1989, pp.154-157.
- [2] R. S. Zhang, "High-Frequency Resonant Gate Driver Circuit for MOSGated Power Switches," U.S. Patent 6441673B1, Aug. 27, 2002.
- [3] R. L. Steigerwald, "Lossless Gate Driver Circuit for a High Frequency Converter," U.S. Patent 5010261, Apr. 23, 1991.
- [4] A. Fiel and T. Wu, "MOSFET Failure Modes in the Zero-Voltage-Switched Full-Bridge Switching Mode Power Supply Applications", In proceedings of Applied Power Electronics Conference and Exposition, APEC 2001, Sixteenth Annual IEEE, vol.2, Anaheim, CA, USA, pp.1247 – 1252, 2001
- [5] L. Saro, R. Redl, K. Dierberger, "High-Voltage MOSFET Behavior in Soft-Switching Converter: Analysis and Reliability Improvements," In

- proceedings of International Tel-communication Conference, San Francisco, 1998, pp 30-40
- [6] D. C. Hamill, "Class DE Inverters and Rectifiers for DC-DC Conversion", In proceedings of Power Electronics Specialists Conf., Baveno, Italy, June 1996
- [7] M. Milan Jovanovic, A. T. Wojciech, C. L. Fred, "Zero-Voltage-Switching Technique in High-Frequency Off-Line Converters", IEEE Proceedings of Applied Power Electronics Conference, pp. 23-32, 1988.
- [8] L. Josef, H. Schlagenotto, U. Scheuermann, R. D. Doncker, "Semiconductor Power Devices, Physics, Characteristics, Reliability", Springer-Verlag Berlin Heidelberg, 2011.
- [9] I.D. Jitaru, "A new high frequency, zero-voltage switched, PWM converter", In proceedings of Applied Power Electronics Conference and Exposition, 1992. APEC '92. Conference Proceedings 1992, Seventh Annual, Page(s): 657 – 664, 1992.
- [10] P. Singh, Power MOSFET Failure Mechanisms, In proceeding of 26th Annual International Telecommunications Energy Conference, 2004. INTELEC 2004, Chicago, Illinois USA, pp. 499 – 502.
- [11] L. Rossetto, G. Spiazio, Series Resonant Converter with wide load range, In proceeding of IEEE Industry Applications Conference, 1998, St. Louis, MO, USA, 12-15 Oct 1998, vol.:2, pp. 1326 - 1331.
- [12] M. K. Kazimierczuk, "Pulse-width Modulated DC-DC Power Converters", John Wiley and Sons, Ltd, 2008, ch. 16.
- [13] B. J. Baliga, "Fundamentals of Power Semiconductor Devices", Springer Science+Business Media, LLC, 2008, ch. 6.
- [14] www.fairchildsemi.com, Application note AN-6076 Design and Application Guide of Bootstrap Circuit for High-Voltage Gate Drive IC, 2008
- [15] Tektronics, P6022 Current Probe Instruction Manual, Tektronix, Inc., 2004
- [16] X. Wei, H. Sekiya, S. Kuroiwa, T. Suetsugu, M. K. Kazimierczuk, "Design of Class-E Amplifier With MOSFET Linear Gate-to-Drain and Nonlinear Drain-to-Source Capacitances", IEEE Transactions on Circuits and Systems I: Regular Papers, Vol. 58, pp. 2556 – 2565, 2011.
- [17] M. Orabi, A. Abou-Alfotouh, A. Lotfi, "Coss Capacitance Contribution to Synchronous Buck Converter Losses" In proceedings of Power Electronics Specialists Conference, PESC 2008, Rhodes, Greece, pp. 666 – 672, 2008.
- [18] Z. Zhang, W. Eberle, Z. Yang, Y. Liu, P. C. Sen, "Optimal Design of Resonant Gate Driver for Buck Converter Based on a New Analytical Loss Model", IEEE Transactions on Power Electronics, vol.23, no.2, pp.653-666, 2008.
- [19] M. P. Theodoridis, S. V. Mollov, "Robust MOSFET Driver for RF, class-D Inverters", IEEE Transactions on Industrial Electronics, vol.55, no.2, pp.731-740, 2008.
- [20] S. Xu, X. Liu, W. Sun, "Modelling of power metal-oxide semiconductor field-effect transistor for the analysis of switching characteristics in half-bridge converters", IET Circuits, Devices & Systems, vol.4, pp. 327 – 336, 2010.