

# A Method for Controlling of Hand Prosthesis Based on Neural Network

Fereidoun Nowshiravan Rahatabad, Mohammad Ali Nekoui, Mohammad Reza Hashemi Golpaygani, Ali Fallah, and Mehdi Kazemzadeh Narbat

**Abstract**—The people are differed by their capabilities, skills and mental agilities. The evolution of human from childhood when they are completely dependent up to adulthood the time they gradually set the dependency free is too complicated, by considering they have all started from almost one point but some become cleverer and some less.

The main control command of a cybernetic hand should be posted by remaining healthy organs of disabled Person. These commands can be from several channels, which their recording and detecting are different and need complicated study. In this research, we suppose that, this stage has been done or in the other words, the command has been already sent and detected. So the main goal is to control a long hand, upper elbow hand missing, by an interest angle define by disabled. It means that, the system input is the position desired by disables and the output is the elbow-joint angle variation. Therefore the goal is a suitable control design based on neural network theory in order to meet the given mapping.

**Keywords**—Control - system design, Upper limb prosthesis, neural network.

## I. INTRODUCTION

AFTER world war two there were a lot of over elbow arm missing, so the need of prosthesis emerged. The primitive aim of artificial hand was to replace the lost organ to strengthen the disabled person mentally [1]. So the cosmetic hand was fabricated. The simplest form of artificial hand had no joint and was equipped with a very simple hook. The most complete hand is one that can act as much as possible as a real hand, which doesn't need a special training for exercise. The artificial hand manufacturing had to be an interesting theme for various research centers word wide. The final aim in this effort is to achieve a hand to be able to imitate the natural movements of a real one as possible. Another major goal in this area is to promote the hand features like distortion reduction and to render an intelligent organ able to learn [1].

F. N. Rahatabad and M. K. Narbat are with Islamic Azad University, Science and Research Branch, Tehran, Iran (phone: 98-21-4447-4321 98-21-8827-9732, 98-912-5163490; e-mail: nooshiravan@yahoo.com & mehdi.kazemzadeh@yahoo.com).

M. A. Nekoui is with Electrical Faculty, K. N. Toosi University of Technology, Tehran, Iran (e-mail: manekoui@eetd.kntu.ac.ir).

M. R. H. Golpaygani and A. Fallah are with Bioelectric Department, Faculty of Biomedical Engineering, Amirkabir University of Technology, Tehran, Iran (phone: 98-21-6454-2383; fax: 98-21-6495-655; e-mail: hashemi\_g@morva.net&d\_af\_21@yahoo.com ).

## II. MATERIAL AND METHOD

In this effort we try to model and investigate a cybernetic hand in order to design an intelligent control method to simulate a hand by neural network. The controllable system parts in artificial hand are the arm, forearm and wrist. To move an arm in supination and pronation direction, we have no problem, since the case is linear and can be resolved by ordinary digital controllers, but in an upper elbow hand missing, the main goal is to reach from one position to another. In such a situation, the load angle variation results in torque alteration, which make the system nonlinear, so a linear controller can not be used alone. By taking all theses into consideration the main concentration of this study will be on flexion and extension movements.

### A. A Controlled System Modeling

#### 1) Forearm and Elbow Modeling

To apply a useful control on artificial hand, firstly we need to present a model for this plant. A simple model used for the flexion and extension movements in a disabled person's hand. Demonstrates in Fig. 1.

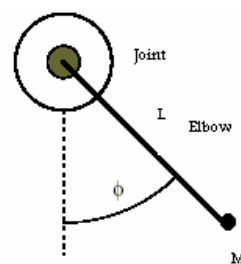

Fig. 1 A simplified model of an artificial forearm and elbow

In above figure, we place a DC motor with constant poles in the elbow. Controlling the angle  $\Phi$  made by the Dc motor Torque is of great interest which results in a controlled movement from one position to another by disable. Note that we suppose, the command and its analysis are well analyzed, available and at disposed.

To obtain the plant equations, we used the Newton's low in rotating motion, as follow:

$$\sum \tau = \alpha . J \quad (1)$$

$$-MgL \sin \Phi - B \dot{\Phi} + U = J \ddot{\Phi} \quad (2)$$

where  $MgL \sin \Phi$  is the load torque, which resists the motor torque or motion, and defined by negative values. The

term  $B \dot{\Phi}$  relates to friction however the coefficient B has been considered as a constant value but is not so in general and can be affected by various factors. In reference [12], the curve of fig2 has been given but because of low friction alteration it was ignored.

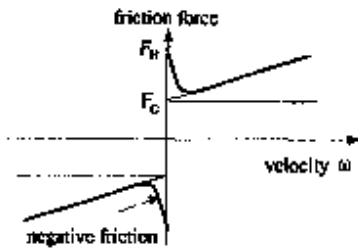

Fig. 2 Friction variation in different motion stage is a function of angular velocity [12]

By transformation the above equations to laplace form, the below block diagram is obtained, shown in (Fig. 3).

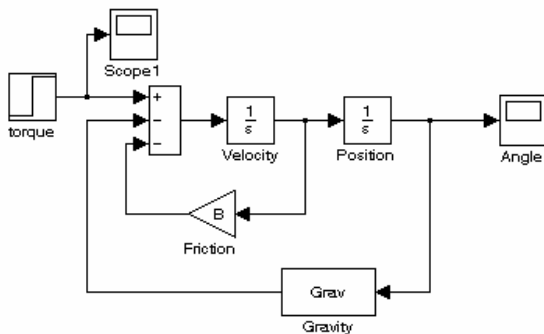

Fig. 3 Ablock diagram regarding the elbow, in which U indicates the imposed torque by DC motor

### 2) Constant Pole DC Motor Model

To move the joint, one DC motor used creating torque  $\tau$ , named "U" in part 1 as system input. Therefore the main control will be the input command to DC motor, hitch move from default position to another one.

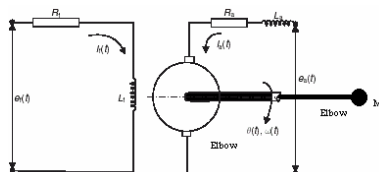

Fig. 4 DC motor illustration for hand movement

The corresponding mathematical equation for this model is as follow:

$$\Phi = k_{fd} i_f \quad (3)$$

Where  $\Phi$  is coil flow and  $k_{fd}$  is coil constant

$$\tau_m(t) = \Phi K_{am}(t) \quad (4)$$

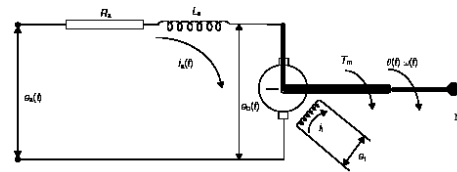

Fig. 5 Elbow joint drive motor illustration

$$\tau_m(t) = (K_{fd} K_{am} i_f) i_a(t) \quad (5)$$

If all constants be showed by  $K_a$  then

$$\tau_m(t) = K_a i_a(t) \quad (6)$$

Motor revolution causes an anti induction force which shown with  $e_b(t)$  and equation:

$$e_b(t) = K_b \frac{d\theta}{dt} = K_b \omega(t) \quad (7)$$

$$e_a - e_b = L_a \frac{di_a}{dt} + R_a i_a \quad (8)$$

$$\tau_m = \left\{ e_a - K_b \omega(t) \right\} \frac{K_a}{R_a} \quad (9)$$

By transforming the equation to laplace form, the relating diagram obtained.

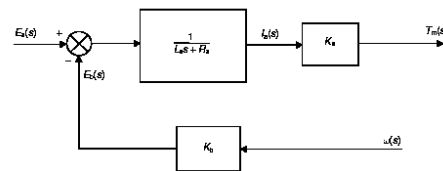

Fig. 6 General DC motor diagram

And the same for coupling circuit we'll have:

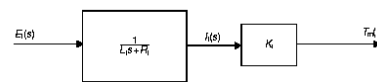

Fig. 7 Artificial hand DC motor coupling circuit model

### 3) Modeling based on DC Motor Voltage as an Input and Elbow Angle Variation as an Output

If a DC motor with constant poles causes the elbow rotation, the following block diagram can be resulted.

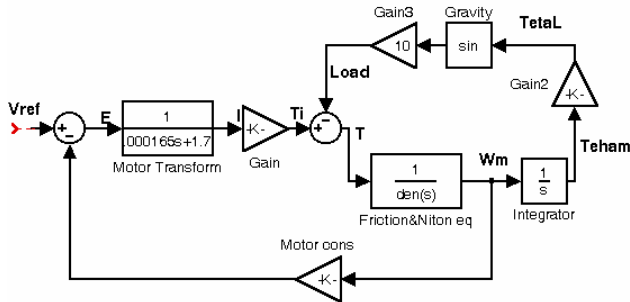

Fig. 8 Block diagram based on DC motor voltage as an input and elbow angle variation as an output

### B. Controller Designed for Cybernetic Hand

The major goal in controller design is to meet following feature along with simplicity.

- 1-Stability in close loop
- 2-Appropriate input tracking
- 3-Disorder reduction and robust control
- 4-Noise reductions
- 5-Energy optimization (Optimum Control)

### C. Uncertainty in Cybernetic Hand Control System

Uncertainty means, model variation around its nominal value with a specific range. This issue will happen definitely in real systems and our struggle in robust control is to reduce these variations as much as possible. Such a system has to resist uncertainty.

According to reference, the controllers based on neural network structure or Neuro-Fuzzy will satisfy this feature.

### D. Controller Design based on Neural Network

In the control of all systems the final goal is a simple, economic and optimized solution, which perfectly adapts our Plant, plus a good learning ability.

Among all controllers capable of learning, the neural network or neurology network can be applied to both linear and nonlinear system. Besides they are intelligent, and follow the inverse Plant learning procedure.

As mentioned before, hand control systems acts as a tracker to reach from one position to another, in the other words our approach is to approach is to make the target close to a desired position [14], as show in Fig. 9.

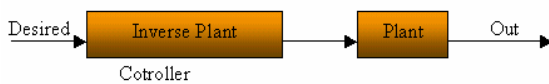

Fig. 9 A tracker controller system block diagram (the final goal is desired signal=output signal)

Neural networks can realize this structure because of its changeable nature in transform function.

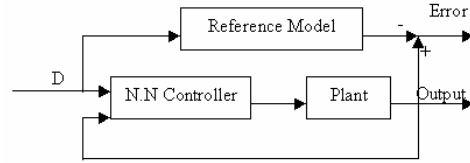

Fig. 10 A complete illustration of system and controller

Fig. 11-block diagram shows the interested controlled plant with torque coming from DC motor and angular output in which the goal is to control the angle  $\Theta$ , to let the joint follow the requested command. For this, MATLAB 6.5.0 software used, an angular feedback obtained from system output applied to system as an error factor.

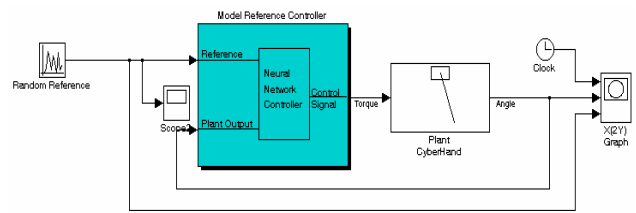

Fig. 11 Using neural network for cybernetic hand control

In this study like any system controlling based on neural network, two different stage followed .In stage one we instruct and train network what the goal is and in stage two we examine the system to see if it works. For training the neural network, the back propagation error method was used.

## III. RESULTS

To use any artificial intelligent system, two stages have to be followed. In stage one, various data fed to system in order to train it by different methods. In stage two, giving it an unknown input and verifying the correct output check the system.

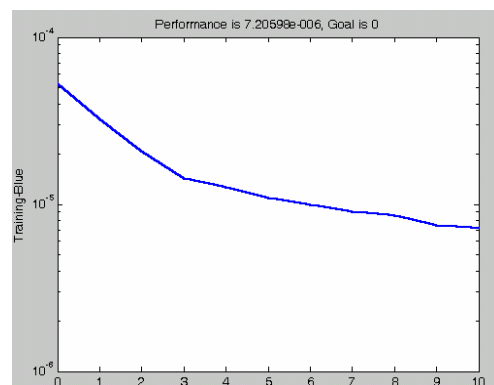

Fig. 12 Error network training after 300 epochs

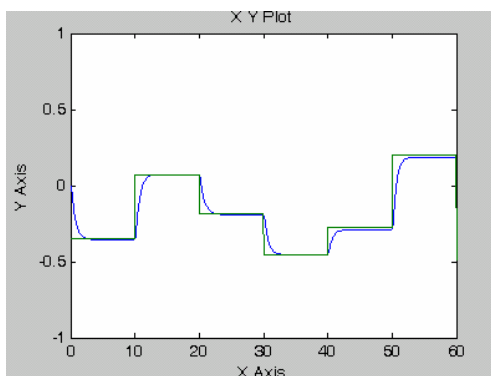

Fig. 13 System response to a random input. Because of system inertia, the input held constant for 10seconds to allow system to follow. It can be seen that output will follow the input under a correct instruction

For test the system, a random value that stays constant within 5 second is fed as an input to let the system follow.

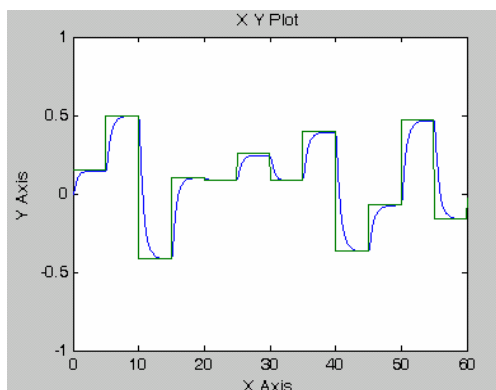

Fig. 14 Output and input curves regarding to 5-second random inputs

Absence of overshoot in this system is an advantage. To test the speed of system and to control the speed of position variation, the following experiment was carried out (system settling time).

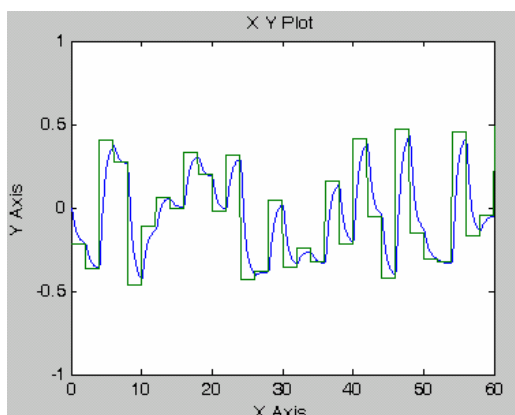

Fig. 15 Output regarding to input variation every one second

As seen, because of the low speed the system, the output couldn't follow the input properly.

#### IV. DISCUSSION AND CONCLUSION

In this study, firstly a proper model to control an artificial hand in flexion and extension motions was investigated, and compared to real case. Then a useful controller based on neural network was designed and evaluated. It was found that the out could follow the input only when the system has proper speed. The neural network was found to be a good approach for flexion and extension of cybernetic hand.

As discussed before, in this study only angle alteration feedback was used for hand control, but it is promising to apply other feedback controller systems in future.

Neural networks can detect the system without knowing its construction (advantage of neural network to resistant and adaptive control). However to inform about and various part of system may lead to design a simple control on neural network and will reduce the complication of control considerably. In this case utilizing several networks instead of one, not only reduce neuron quantity but also will increase the response speed. Therefore, the more information over system control will be which tend to an adaptive control.

The final goal in this paper will be to investigate other cybernetic hand joints from controlling point of view and to achieve a fully controlled system for controlling all joints including fingers and wrist, in which various feedbacks similar to natural hand and a maximum adoption with the remaining organ exist.

#### REFERENCES

- [1] A. Fallah, A. A. Moradi, and R. Mikaili, "Control of the Electric Motor in Cybernetic Arm and Review of Parameters Values", 10th EMCSR 1990 Austrain.
- [2] Fredrik C. P. Sebelius, Birgitta N. Rosen, "Refined Myoelectric Control in Below-Elbow Amputees Using Artificial Neural Networks and a Data Glove", The Journal of Hand Surgery, 2005.
- [3] Michele Folgheraiter, Marek Perkowski, "Adaptive Reflex Control for an Artificial Hand", ECE Department, Portland State University, 2002.
- [4] Michele Folgheraiter, "Human-like reflex control for an artificial hand", ELSEVIER, BioSystem, 2003.
- [5] M. Reischl, R.Mikut, C. Pylatiuk, S.Schulz, "Control Strategies for Hand Protheses Using Myoelectric Patterns", Institute of Applied Computer Science (IAI), 2000.
- [6] M Canina, F. Vicentini, A.Rovetta, "Innovative Design, Development and Prototyping of Knee Prosthesis", Robotics Laboratory-Mechanical Dept, 2004.
- [7] H.Grant, C. K.Lai, "Simulation Modeling with Artificial Reality Technology (SMART): An Integration of Virtual Reality and Simulation Modeling", School of Industrial Engineering,Proceeding of the 1998 Winer Simulation Conference.
- [8] Quing-chang zang, "Robust Control of Time-delay Systems," Springer, 2006.
- [9] Matthias Rauterberg, "How to Measure Cognitive Complexity in Human-Computer Interaction," Work and Organizational Psychology Unit Swiss Federal Institute Technology (ETH).
- [10] M.Kawato,y.Uno,M.Isobe and R.Suzuki, "Hierarchical Neural Network Model for Voluntary Movement with Application to Robotics,"IEEE Control System Magazine,1998.
- [11] Kia Nichel and Rainer Stiefelhagen, " Visual Recognition of Pointing Gestures for Human-Robot Interaction," Elsevier, 2006.
- [12] T. Derosam and T. Fisher "Aspects of controlling multifinger gripper," Elsevier, 1998.
- [13] C.M. Light and P.H Chappell, "Development of a Light Weight and Adaptable Multiple- Axis Hand Prosthesis,"Elsevier, 2001.
- [14] Panson J. Antaski and Kievin M. Pssiono "An Introduction to Intelligent and autonomous control," University of north dam, 1993.