

# Distributed Architecture of an Autonomous Four Rotor Mini-Rotorcraft based on Multi-Agent System

H. Ifassiouen, H. Medromi, and N. E. Radhy

**Abstract**—In this paper, we present the recently implemented approach allowing dynamics systems to plan its actions, taking into account the environment perception changes, and to control their execution when uncertainty and incomplete knowledge are the major characteristics of the situated environment [1],[2],[3],[4].

The control distributed architecture has three modules and the approach is related to hierarchical planning: the plan produced by the planner is further refined at the control layer that in turn supervises its execution by a functional level. We propose a new intelligent distributed architecture constituted by: Multi-Agent subsystem of the sensor, of the interpretation and representation of environment [9], of the dynamic localization and of the action.

We tested this distributed architecture with dynamic system in the known environment. The autonomous for Rotor Mini Rotorcraft task is described by the primitive actions. The distributed control based on multi-agent system is in charge of achieving each task in the best possible way taking into account the context and sensory feedback.

**Keywords**—Autonomous four rotors helicopter, Control system, Hierarchical planning, Intelligent Distributed Architecture.

## I. INTRODUCTION

THIS paper presents the distributed real time architecture that we have developed recently of an autonomous four rotors helicopter based on multi-agent system in a barely known environment.

The methodology is a key issue in the development of any complex system and there is currently no standard or widely used methodology in the realm of multi agent systems.

In order to achieve this, we developed two main levels based on multi-agent system.

**The multi-agent subsystem of the decisional level:** is the Dynamic system mission and it is described as a set of tasks.

**The multi-agent subsystem of the functional level:** is the distributed architectural of the control and it is described by the multi-agent system.

H. Ifassiouen is with LAPGI, ESTC, BP. 8012 Oasis Casablanca, Morocco (e-mail: ifassiouen@gmail.com).

H. Medromi is with EAS, ENSEM, BP. 8118, Oasis Casablanca, Morocco (e-mail: hmedromi@menara.ma).

N. E Radhy is with LAI, Faculté des science Ain chock, BP 5366 - Maârif Casablanca, Morocco (e-mail: nradhy@hotmail.com).

The high-level distributed control of the different processing multi-agent subsystem is handled by a propositional theorem prover which is able to provide on-board reactive decisional capabilities. Execution control of predefined plans leads to the development of generic methods called plan families. The principle of this distributed architecture control is given by the Fig. 1.

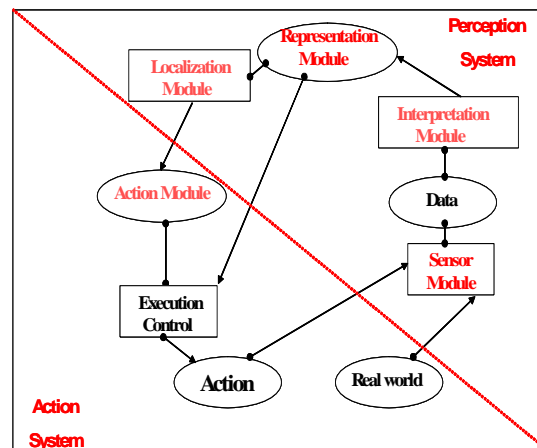

Fig. 1 Distributed architecture

This paper is organized as follows: section 2 presents our multi-agent and the different subsystem; in section 3; we expose the interpretation and representation multi-agent system; then, in section 4, we describe the multi-agent of localization; then, in section 5, we expose the multi-agent of action with the multi-agent subsystem of the decisional level and the multi-agent subsystem of the functional level;

In section 6, we describe the experiences and results of our distributed architecture for an autonomous helicopter based on multi-agent system; finally, in section 7, we conclude on the major benefits of our works and we talk about the extensions and problems we are currently working on.

## II. MULTI-AGENT OF SENSOR

Our system is based on two multi-agent subsystems to undertake measures from tasks. In order to have a model of environment, we proposed two approaches, optimal and precise.

### A. Optimal Multi-Agent Subsystem

The optimal multi-agent is based on a structural approach of the intelligent model with a time of optimal processing [6],[8]. This module includes a physical sensor model, a modulation card, a reception card, a feeding card and a model of processing.

### B. Precise Multi-Agent Subsystem

The precise multi-agent is based on a structural approach of the intelligent model where the time of processing is not optimal but more accurate.

## III. MULTI-AGENT OF INTERPRETATION AND REPRESENTATION

We use for the multi-agent data interpretation two methods. The first is optimal based on the magnitude and the time of flight of an optimal number of signals. The second is more accurate based on an important number of magnitudes and time of flight for the same object, so as to form a cloud of data [5],[7],[8].

For the representation of environment, we used a new physical approach based on signal analysis and using the empirical functional models [8].

## IV. MULTI-AGENT OF LOCALIZATION

We propose a generalized multi-agent of localization for environment in two dimensional and three dimensional [8]. This system is based on the optimization of errors between sensor measures and the real model of object.

## V. MULTI-AGENT OF ACTION

The architectural specification of the control distributed system lies in its ability to conciliate between the decision process and the reaction process. The distributed architecture of our dynamic system is a hierarchical architecture. It is composed of two main levels.

### A. The Decisional Level

The dynamic system mission is described as a set of tasks to be achieved. At this mission planning layer, the task decomposition is very rough and does not take into account the execution context and model of each elementary action. The planner orders tasks by a forecasting into the future; it does that without the knowledge the real execution context, its projection is done only by the add/delete list which is the list of predicates changes. In addition, such a planner is able to deal with temporal reasoning. We will not tackle this level here.

So, between the predicted world, differences may occur and we need some flexibility to suit tasks to real world dynamic system surrounding. This has to be done at the execution control layer. More precisely, the control is in charge of achieving each task in the best possible way decomposing it, taking into account the context and perception feedback. It has to evaluate, in a flexible way, how successful an elementary

action has been, and, depending on that evaluation, pursue on the next action or adapt its plan for achieving the task to the current context. The execution control layer exchanges data with the other layers.

In case the dynamic system finds a problem, or one or more actions have not been performed properly, the controller suspends the execution of the task and asks the dynamic system to go back to its initial state. The controller can decide to halt the system at any time during the execution of the task.

For each plan, there are some precise actions associated with it. When the planner sends a new plan to the controller, the latter chooses the corresponding actions and sends them to the functional level.

### B. The Functional Level

The functional level (where the sensors module and the interpretation and representation module and localization module are integrated in the distributed architectural of the control) implements all the dynamic system basic capabilities in sensing, acting and computing through this concept. These functionalities are grouped according to data or resource sharing, and integrated into layers. This level is composed of the execution layer, the transformation layer, the localization layer, the interpretation and representation layer and the sensor layer.

## VI. EXPERIENCES AND RESULTS

Our system of the distributed architecture for an autonomous helicopter based on multi-agent system was implemented.

We examine the example shown on Fig. 2. The task of moving merchandise consists of the dynamic system moving from its starting position to its final destination position while passing through different well defined points. In this trip, the dynamic system must avoid any obstacles.

The four rotors helicopter presented in Fig. 2 is an autonomous flying vehicle known as a quadrotor or X4 flyer will be suitable for civil and military domain, the fields of application of this vehicle are vast. We can state the ecological exploration mission and air cartography, search and rescue, surveillance and remote inspection. It is easy to handle, able to make hovering and can take off or land vertically. Moreover, their configuration appears particularly interesting for some applications, where stability and reliability are of primary importance. Indeed, this helicopter is mechanically very simple, inexpensive and simple to design and to construct. It has also a weak catch with the wind; this increases its stability in disturbed environment.

The four rotors helicopter is an under actuated dynamic vehicle with four input forces and six output coordinates. Unlike regular helicopter that have variable pitch angle rotors, a quadrotor helicopter has four fixed pitch angle rotors. Advantages of using a multi-rotor helicopter are the increased payload capacity and high manoeuvrability and the fact that the two motors turn in the clockwise direction whereas the two other turn in the opposite clockwise direction, gyroscopic

effects and aerodynamic torques tend to cancel in trimmed flight. Disadvantages are the increased helicopter weight and increased energy consumption due to the extra motors.

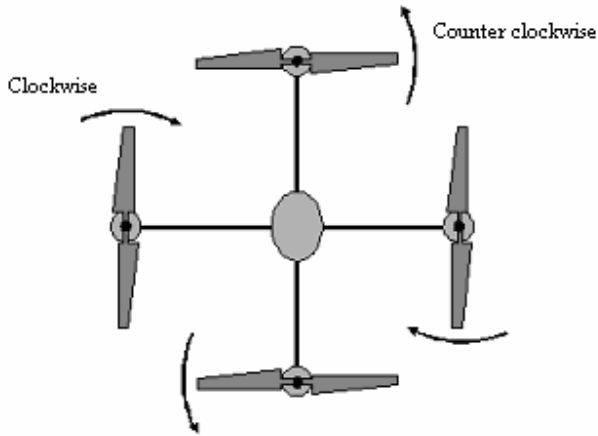

Fig. 2 Upper view of the four rotor rotorcraft

#### A. Multi-Agent Model of the Four Rotors Helicopter

In this subsection, we develop the Newtonian model of a four rotors helicopter consisting of rigid cross bars, each of which supports two motors, equipment (controller cartes, sensors, etc). The four rotors helicopter is assumed to be a rigid body, having six degrees of freedom, and subject to external efforts. The vertical motion is controlled by collectively increasing or decreasing the speed of all motors. The horizontal motion is achieved by differentially controlling the motors generating a pitching/rolling motion of the helicopter that inclines the collective thrust. The roll motion is obtained by increasing (reducing) the speed of the rear motor while reducing (increasing) the speed of the front motor. The pitch motion is obtained similarly using the lateral motors. The yaw motion is obtained by increasing (decreasing) the speed of the front and rear motors while decreasing (increasing) the speed of the lateral motors. This should be done while keeping the total thrust constant.

Let  $\mathfrak{R}_O = \{O, e_X, e_Y, e_Z\}$  denote an inertial reference frame attached to the ground, and  $\mathfrak{R}_G = \{G, e_1, e_2, e_3\}$  denote a local body fixed frame attached to the centre of mass of the vehicle as shown in Fig. 2.

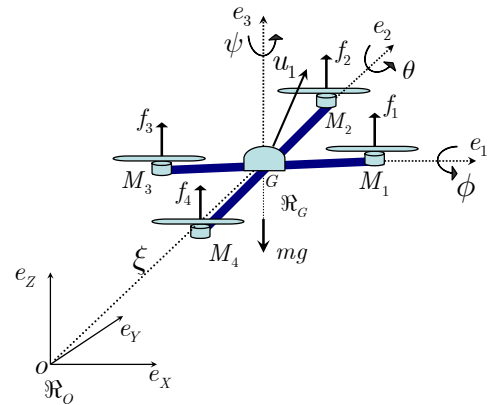

Fig. 3 Four rotors helicopter with forces and frames

The position of the helicopter is given by three coordinates  $\xi = (X, Y, Z) \in \mathbb{R}^3$  of its centre of mass with respect to the inertial reference frame  $\mathfrak{R}_O$  and its orientation by the three Euler angles  $\eta = (\psi, \theta, \phi) \in \mathbb{R}^3$ . These angles are called the yaw ( $-\pi < \psi < \pi$ ), the pitch ( $-\pi/2 < \theta < \pi/2$ ) and the roll ( $-\pi/2 < \phi < \pi/2$ ), respectively. The vector  $v = (v_X, v_Y, v_Z) \in \mathbb{R}^3$  denotes the linear velocity of the center of mass of the helicopter in  $\mathfrak{R}_O$ ,  $\Omega = (\Omega_1, \Omega_2, \Omega_3) \in \mathbb{R}^3$  denotes the angular velocity of the vehicle expressed in the body fixed frame  $\mathfrak{R}_G$ . The derivative of the Euler coordinate with respect to time can be expressed by:

$$\dot{\eta} = \mathcal{W}(\eta)\Omega \quad (1)$$

$$\text{where } \mathcal{W}(\eta) = \begin{pmatrix} 0 & \sin \phi / \cos \theta & \cos \phi / \cos \theta \\ 0 & \cos \phi & -\sin \phi \\ 1 & \sin \phi \tan \theta & \cos \phi \tan \theta \end{pmatrix}$$

The rotation matrix  $R : \mathfrak{R}_G \rightarrow \mathfrak{R}_O$  representing the orientation of the helicopter relative to the fixed inertial frame  $\mathfrak{R}_O$ , is given by:

$$R \doteq R(\eta) = \begin{pmatrix} c_\psi c_\theta & c_\psi s_\theta s_\phi - s_\psi c_\phi & c_\psi s_\theta c_\phi + s_\psi s_\phi \\ s_\psi c_\theta & s_\psi s_\theta s_\phi + c_\psi c_\phi & s_\psi s_\theta c_\phi - c_\psi s_\phi \\ -s_\theta & c_\theta s_\phi & c_\theta c_\phi \end{pmatrix}$$

where  $c_\Psi \doteq \cos \Psi$  and  $s_\Psi \doteq \sin \Psi$ ,  $\Psi = \{\psi, \theta, \phi\}$ .

The total thrust produced by the four rotors is given by:

$$u_1 = f_1 + f_2 + f_3 + f_4$$

where  $f_i = b_i \omega_i^2$  is the thrust generated by the rotor  $i \in \{1, 2, 3, 4\}$  and  $\omega_i$  is the angular speed generated by the motor  $M_i$  and  $b_i > 0$  is a parameter.

The torques acting of the four rotors helicopter result from the action of the thrust forces difference of each pair of rotors are denoted by:  $\tau = (\tau_1, \tau_2, \tau_3)$  around axes  $e_1, e_2$  and  $e_3$  respectively, with

$$\tau_1 = (f_2 - f_4)d; \quad \tau_2 = (f_3 - f_1)d \quad \text{and} \\ \tau_3 = (f_2 + f_4 - f_1 - f_3)\kappa$$

where  $d$  represents the distance from the rotors to the centre of gravity of the helicopter and  $\kappa > 0$  is a constant.

Applying the Newton equation of Mechanics, we obtain the dynamical model for the four rotors helicopter:

$$\begin{cases} \dot{\xi} = v \\ m\dot{v} = \begin{pmatrix} 0 \\ 0 \\ -mg \end{pmatrix} + R(\eta) \begin{pmatrix} 0 \\ 0 \\ u_1 \end{pmatrix} \\ \dot{\eta} = \mathcal{W}(\eta)\Omega \\ \mathbb{I}\dot{\Omega} = -\Omega \times \mathbb{I}\Omega + \tau \end{cases} \quad (2)$$

where  $m$  is the total mass of the helicopter,  $g$  represents the acceleration due to gravity and  $\mathbb{I} = \text{diag}(\mathbf{I}_{XX}, \mathbf{I}_{YY}, \mathbf{I}_{ZZ})$  is a diagonal matrix representing the inertia matrix of the helicopter expressed in the body fixed frame. The notation  $\times$  denotes the vector cross-product.

Finally the continuous-time model of the helicopter is the following form:

$$\begin{cases} \dot{\xi} = v \\ \dot{\eta} = \mathcal{W}(\eta)\Omega \\ \dot{v} = \varphi_1(\eta, u_1) \\ \dot{\Omega} = \varphi_2(\Omega, \tau) \end{cases} \quad (3)$$

where

$$\varphi_1(\eta, u_1) = \begin{pmatrix} 0 \\ 0 \\ -g \end{pmatrix} + \frac{1}{m} \begin{pmatrix} \cos \psi \sin \theta \cos \phi + \sin \psi \sin \phi \\ \sin \psi \sin \theta \cos \phi - \cos \psi \sin \phi \\ \cos \theta \cos \phi \end{pmatrix} u_1$$

and

$$\varphi_2(\Omega, \tau) = \begin{pmatrix} \Omega_2 \Omega_3 (\mathbf{I}_{YY} - \mathbf{I}_{ZZ}) / \mathbf{I}_{XX} \\ \Omega_1 \Omega_3 (\mathbf{I}_{ZZ} - \mathbf{I}_{XX}) / \mathbf{I}_{YY} \\ \Omega_1 \Omega_2 (\mathbf{I}_{XX} - \mathbf{I}_{YY}) / \mathbf{I}_{ZZ} \end{pmatrix} + \mathbb{I}^{-1} \tau$$

Consequently, system (30) can be written in the following form:

$$\begin{cases} \dot{x} = F(y)x + \varphi(x, u) \\ y = Cx \end{cases} \quad (4)$$

$$\text{where } x = \begin{pmatrix} x^1 \\ x^2 \end{pmatrix}, \quad x^1 = \begin{pmatrix} \xi \\ \eta \end{pmatrix}, \quad x^2 = \begin{pmatrix} v \\ \Omega \end{pmatrix}, \quad y = \begin{pmatrix} \xi \\ \eta \end{pmatrix},$$

$$F(y) = \begin{pmatrix} 0 & F^1(y) \\ 0 & 0 \end{pmatrix}, \quad F^1(y) = \begin{pmatrix} I_3 & 0 \\ 0 & \mathcal{W}(\eta) \end{pmatrix},$$

$$\varphi(x, u) = \begin{pmatrix} 0 \\ \bar{\varphi}(x, u) \end{pmatrix}, \quad \bar{\varphi}(x, u) = \begin{pmatrix} \varphi_1(x, u) \\ \varphi_2(x, u) \end{pmatrix}, \quad u = \begin{pmatrix} u_1 \\ \tau \end{pmatrix}$$

and  $C = [I_6 \ 0]$ .

### B. Multi-Agent of Localization

In this part, we consider that the position and orientation of the rotorcraft are measurable as in [11], where the 3D tracker system (Polhemus) is used for these measures; and we apply the above observer synthesis designed in [12], to estimate the linear and angular velocities.

Now consider the forward Euler discretization of the continuous-time model (4):

$$\begin{cases} x(k+1) = x(k) + T_s F(y(k))x(k) + T_s \varphi(x(k), u(k)) \\ y(k) = Cx(k) \end{cases} \quad (5)$$

The multi-agent discrete-time observer permitting to estimate the linear and angular velocities takes the following form [13],[14]:

$$\begin{aligned} \hat{x}(k+1) = & \hat{x}(k) + T_s F(y(k))\hat{x}(k) + T_s \varphi(\hat{x}(k), u(k)) \\ & - \Delta_{\Theta}^{-1} H_k (C\hat{x}(k) - y(k)) \end{aligned} \quad (6)$$

where  $\Delta_{\Theta} = \text{diag}(\Theta I_6, \Theta^2 I_6)$  and  $H_k$  is such that the spectrum of  $(I_{12} + \Theta^{-1}(T_s F_k - H_k C))$  is included in  $D(0, 1)$  and  $\Theta > 0$

### C. Simulation Results

The multi-agent subsystem observer design is applied to the four rotors helicopter to estimate the linear and angular velocities from the measurements of the position and orientation using numerical simulations.

The physical parameters of the helicopter used in the simulation are given in Table I.

TABLE I  
 THE PARAMETER VALUES OF HELICOPTER

parameter	Value	units
$m$	0.56	Kg
$g$	9.8	$m.s^{-2}$
$I_{XX}$	0.0142	$Kg.m^2$
$I_{YY}$	0.0142	$Kg.m^2$
$I_{ZZ}$	0.0284	$Kg.m^2$
$d$	0.21	m
$T_s$	0.01	s

The simulation was performed under the following numerical values [13]:

The initial states of the four rotors helicopter are:

$$\xi = (0, 0, 0)[cm], v = (0, 0, 0)[m.s^{-1}],$$

$$\eta = (0, 0, 0)[^\circ], \Omega = (0, 0, 0)[rd.s^{-1}]$$

The initial states of the observer are given by:

$$\hat{\xi} = (10, 10, 20)[cm],$$

$$\hat{v} = (0.5, 0.5, 0.5)[m.s^{-1}], \hat{\eta} = (10, 10, 10)[^\circ],$$

$$\hat{\Omega} = (0.8, 0.8, 0.8)[rd.s^{-1}]$$

The parameter  $\Theta$  of the observer is tuned at  $\Theta = 5$  and the gain matrix  $H_k$  is chosen to make

$(I_{12} + \Theta^{-1}(T_s F_k - H_k C))$  stable with the vector of poles

$$\sigma = (\sigma_1, \dots, \sigma_{12}) \in \mathbb{C}^{12}, \quad \sigma_1 = 0.7, \quad \sigma_2 = 0.71, \\ \sigma_3 = 0.72, \quad \sigma_4 = 0.73, \quad \sigma_5 = 0.74, \quad \sigma_6 = 0.75, \\ \sigma_7 = 0.76, \quad \sigma_8 = 0.77, \quad \sigma_9 = 0.78, \quad \sigma_{10} = 0.79, \\ \sigma_{11} = 0.8, \quad \sigma_{12} = 0.81.$$

The control inputs are chosen as:

$$u_1(k) = 10mg \sin(0.8k)[N],$$

$$\tau(k) = (0.5 \sin(0.5k), 0.5 \sin(0.5k), 0.5 \sin(0.5k))[N.m].$$

In order to evaluate the robustness of the proposed estimator, the output measurements of the helicopter have been corrupted by an additive noise with zero mean and an amplitude equivalent to 10% of the corresponding values.

Fig. 4 shows the position and orientation of the four rotors and their estimates. Fig. 5 shows the linear and angular velocity compared to their estimates. From both the figures, we can see that the estimate states converge to the true states and a good behaviour of the estimator with respect to noisy output measurements.

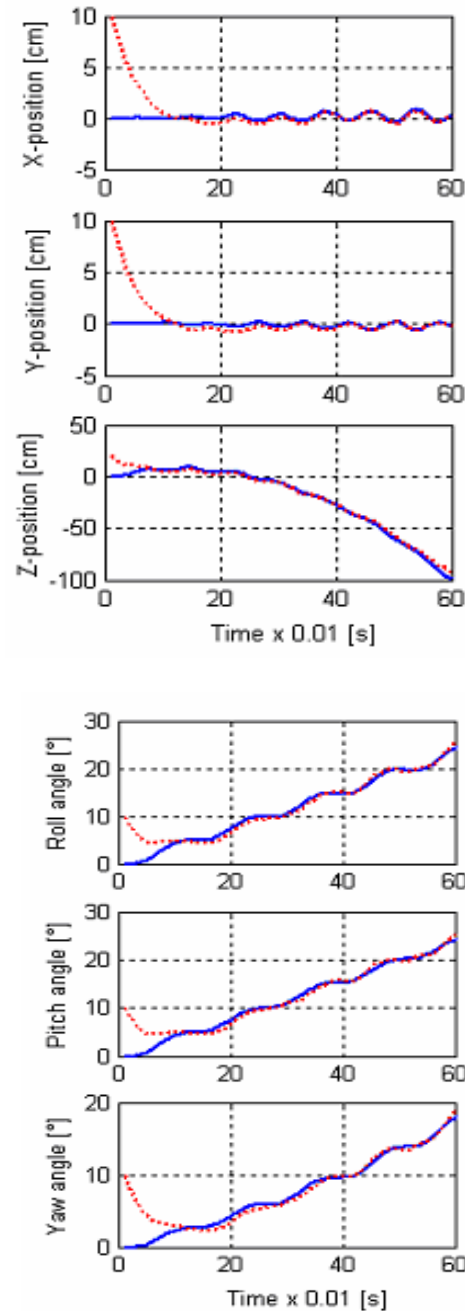

Fig. 4 Position and orientation of the four rotors helicopter and their estimates - Solid lines denote true values and dashed estimated

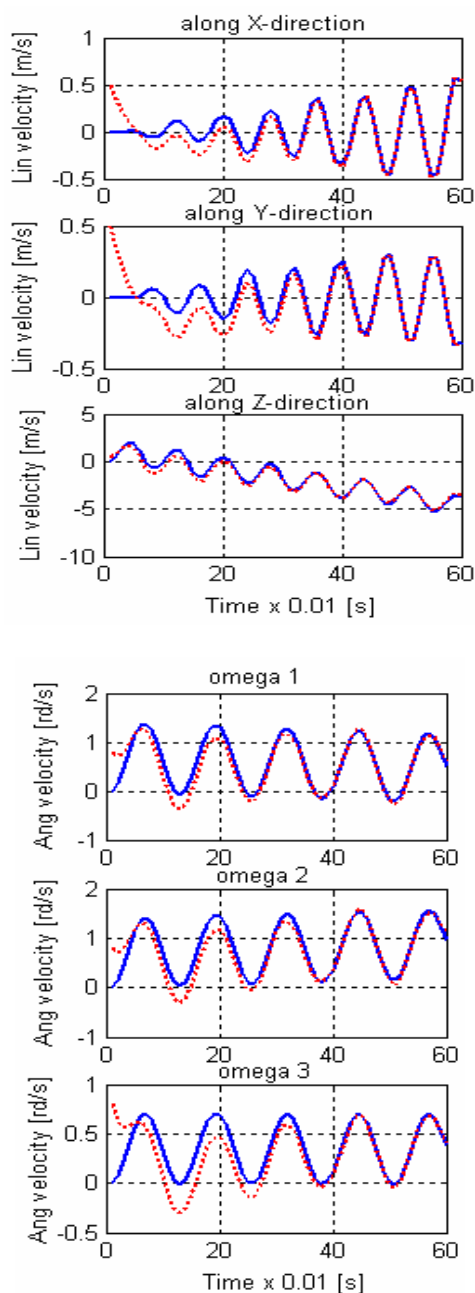

Fig. 5 Linear and angular velocities of the four rotors helicopter and their estimates - Solid lines denote true values and dashed estimated

## VII. CONCLUSION

The realization of our distributed architecture is insured by the idea and the realization of the autonomous Four Rotor Mini-Rotorcraft.

In this architecture, we have considered the multi-agent localization characterized by state estimation problem [10] for a class of Euler discretized nonlinear systems including the Newtonian dynamical systems with position measurements; the existence of an exponential observer is shown which the gain matrix of the observer is variable and derives from the pole placement techniques. Simulation results have been done

to evaluate the performance and robustness of the proposed estimator for a four rotors helicopter modelled via Newtonian approach, to estimate the linear and angular velocities when the measured position and orientation are noisy.

The experimental results were satisfactory. The principles used in our distributed architecture are general and can be applied to a wide range of environment situation which results in the autonomy of the Mini-Rotorcraft. Currently our architecture is operational but it remains to study the global sturdiness of the different modulate.

## REFERENCES

- [1] B. Degallaix, J. Thibault, and M. Ghallab. Propositional logic Applied to execution control. In proceedings of the 1992 International conference on Intelligent Robots and Systems, Raleigh, pages 317-324, July 1992.
- [2] D. Dubois, J. Lang & H. Prade, "Possibilistic Logic Handbook of Logic in Artificial Intelligence and Logic Programming", Gabbay & Hogger & Robinson (eds). Pages 439-511, Clarendon Press.
- [3] J.A. Fodor & Z.W. Pylyshyn, "Connectionism and Cognitive Architecture: a Critical Analysis, in S. Pinker and J. Mehler (eds), Connections and symbols", MIT Press, 1988.
- [4] M. Ghallab and H. Laruelle. Representation and Control in IxTeT, a temporal planner. In Second Artificial Intelligence Planning System (AIPS94), Chicago, June 1994.
- [5] P. Grandjean, M. Ghallab & E. Dekneuveil, "Multisensor Scene Interpretation Model-Based Object Recognition", In IEEE International Conference on Robotics and Automation, Sacramento, USA, Avril 1991.
- [6] H. Medromi, J.Y. Tigli & M.C Thomas, "Posture Estimation of Mobile Robots: Observers-Sensors", IEEE International Conference on Multisensor Fusion and Intelligent Systems, Las Vegas, USA, October 1994.
- [7] H. Medromi, E. Zaafrani, E. Dekneuveil, A. El Hassani & M.C. Thomas, "Intelligent Control Architecture for Mobile Robot based Fusion Methods", IEEE International Symposium on Industrial Electronics ISIE'97, Guimaraes, Portugal, July 1997.
- [8] H. Medromi, J. Saadi & A. EL Hassani, "Réalisation d'un Système d'Interprétation de Données, de Représentation et de Localisation Dynamique d'Environnement pour l'Automatisation d'un Système Mobile", Quatrième Conférence Internationale sur les Mathématiques Appliquées et les Sciences de l'Ingénieur CIMASI'2002, Casablanca, Octobre 2002.
- [9] M.J. Rendas & S. Rolfes, "Path Planning in Extended Uncertain Environments", IECON'98, Aachen, Germany, August - September 1998.
- [10] M. Juny, S.I. Roumeliotisy, G.S. Sukhatmez: State estimation of an autonomous helicopter using Kalman Filtering, Proc. 1999 IEEE/RSJ International Conference on Robots and Systems (IROS 99).
- [11] P. Castillo, A. Dzul, R. Lozano, Real-time stabilization and tracking of a four rotor mini rotorcraft, IEEE Transaction on Control Systems Technology, vol. 12, no. 4, July 2004.
- [12] A. EL Assoudi, E. EL Yaagoubi, H. Hammouri: Nonlinear observer on the Euler discretization, Int. J. Control, vol. 75, no. 11, 784-791, 2002.
- [13] M. Guisser, H. Medromi, H. Ifassiouen, J. Saadi, N E. Radhy: "Discrete-Time Observer Design for a Class of Nonlinear Systems Including Newtonian Mechanical models: Application to an Autonomous Four Rotors Helicopter", IECON2006, Paris - France - November 7-10, 2006.
- [14] M. Guisser, H. Medromi, H. Ifassiouen, J. Saadi, N E. Radhy: "A Coupled Nonlinear Discrete-Time Controller and Observer Designs for Under-actuated Autonomous vehicles with Application to a Quadrotor Aerial Robot", IECON2006, Paris - France - November 7-10, 2006.