

GRNN Application in Power Systems Simulation for Integrated SOFC Plant Dynamic Model

N. Nim-on, and A. Oonsivilai

Abstract—In this paper, the application of GRNN in modeling of SOFC fuel cells were studied. The parameters are of interested as voltage and power value and the current changes are investigated. In addition, the comparison between GRNN neural network application and conventional method was made. The error value showed the superlative results.

Keywords—SOFC, GRNN, Fuel cells.

I. INTRODUCTION

POPULATION increase and economic growth lead to energy consumption. While the limited reserve energy is reduced, the fuel cells price increase. In addition, fossil fuel combustion leads to change in environment that affects lives and environmental system. Thus, seeking for replace energy for fossil fuel is necessary because it does not affect environment including fuel cell energy could be the best way for energy replacement due to its clean and friendly to environmental.

A. Fuel Cells

A fuel cell is a device that converts the chemical energy from a fuel into electricity through a chemical reaction with oxygen or another oxidizing agent. Hydrogen is the most common fuel, but hydrocarbons such as natural gas and alcohols like methanol are sometimes used. Fuel cells are different from batteries in that they require a constant source of fuel and oxygen to run, but they can produce electricity continually for as long as these inputs are supplied.

Welsh Physicist William Grove developed the first crude fuel cells in 1839. The first commercial use of fuel cells was in NASA space programs to generate power for probes, satellites and space capsules. Since then, fuel cells have been used in many other applications. Fuel cells are used for primary and backup power for commercial, industrial and residential buildings and in remote or inaccessible areas. They are used to power fuel cell vehicles, including automobiles, buses, forklifts, airplanes, boats, motorcycles and submarines.

There are many types of fuel cells, but they all consist of an anode (negative side), a cathode (positive side) and

an electrolyte that allows charges to move between the two sides of the fuel cell. Electrons are drawn from the anode to the cathode through an external circuit, producing direct current electricity. As the main difference among fuel cell types is the electrolyte, fuel cells are classified by the type of electrolyte they use. Fuel cells come in a variety of sizes. Individual fuel cells produce relatively small electrical potentials, about 0.7 volts, so cells are "stacked", or placed in series, to increase the voltage and meet an application's requirements. In addition to electricity, fuel cells produce water, heat and, depending on the fuel source, very small amounts of nitrogen dioxide and other emissions. The energy efficiency of a fuel cell is generally between 40–60%, or up to 85% efficient if waste heat is captured for use.

B. High Temperature Fuel Cells

Solid oxide Fuel Cell: SOFC

Solid oxide fuel cells use a solid material, most commonly a ceramic material called yttria-stabilized zirconia (YSZ), as the electrolyte. Because SOFCs are made entirely of solid materials, they are not limited to the flat plane configuration of other types of fuel cells and are often designed as rolled tubes. They require high operating temperatures (800 to 1000 °C) and can be run on a variety of fuels including natural gas.

SOFCs are unique in that negatively charged oxygen ions travel from the cathode (negative side of the fuel cell) to the anode (positive side of the fuel cell) instead of positively charged hydrogen ions travelling from the anode to the cathode, as is the case in all other types of fuel cells. Oxygen gas is fed through the cathode, where it reacts with electrons to create oxygen ions. The oxygen ions then travel through the electrolyte to react with hydrogen gas at the anode. The reaction at the anode produces electricity and water as by-products. Carbon dioxide may also be a by-product depending on the fuel, but the carbon emissions from an SOFC system are less than those from a fossil fuel combustion plant. The chemical reactions for the SOFC system can be expressed as follows:

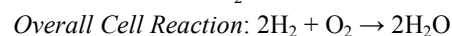
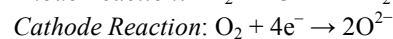
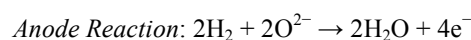

M.F. Karim is with the Institute Technology Brunei, Brunei (phone: +673 7157167; e-mail: mdfazlulkk@yahoo.com).

M. A. Meah is with the Shahjalal University of Science and Technology, Bangladesh Institute Technology Brunei, Brunei (e-mail: mamsust@yahoo.com).

A.I.M. Ismail is with the Universiti Sains Malaysia, Malaysia (e-mail: izani@cs.usm.my).

SOFC systems can run on fuels other than pure hydrogen gas. However, since hydrogen is necessary for the reactions listed above, the fuel selected must contain hydrogen atoms. In order for the fuel cell to operate, the fuel must be converted into pure hydrogen gas. SOFCs are capable of internally reforming light hydrocarbons such as methane (natural gas), propane and butane. Heavier hydrocarbons including gasoline, diesel fuel, jet fuel and biofuels can serve as fuels in a SOFC system, but an external reformer is required.

Challenges exist in SOFC systems due to their high operating temperatures. One such challenge is the potential for carbon dust to build up on the anode, which slows down the internal reforming process. Research to address this "carbon coking" issue at the University of Pennsylvania has shown that the use of copper-based cermet (heat-resistant materials made of ceramic and metal) can reduce coking and the loss of performance. Another disadvantage of SOFC systems is slow start-up time, making SOFCs less useful for mobile applications. Despite these disadvantages, a high operating temperature provides an advantage by removing the need for a precious metal catalyst like platinum, thereby reducing cost. Additionally, waste heat from SOFC systems may be captured and reused, increasing the theoretical overall efficiency to as high as 80%–85%.

The high operating temperature is largely due to the physical properties of the YSZ electrolyte. As temperature decreases, so does the ionic conductivity of YSZ. Therefore, to obtain optimum performance of the fuel cell, a high operating temperature is required. According to their website, Ceres Power, a UK SOFC fuel cell manufacturer, has developed a method of reducing the operating temperature of their SOFC system to 500–600 degrees Celsius. They replaced the commonly used YSZ electrolyte with a CGO (cerium gadolinium oxide) electrolyte. The lower operating temperature allows them to use stainless steel instead of ceramic as the cell substrate, which reduces cost and start-up time of the system.

In this paper, SOFC modeling system was studied and also comparison with GRNN program was done.

II. SOFC MODELING

The SOFC modeling was created following reviewed from previous research work. In the modeling test, the hydrogen current and flow rate are the constant parameters applied. The results and correction of program were monitored and shown in the following.

SOFC modeling system include detailed as in the following:

A. Although the CO could be the fuel source in **SOFC**, the reaction in conversion of CO with water in system to be CO₂ and H₂ is shown below.

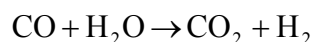

When use this conversion as the basic, there are only H₂ and O₂ that were sent into fuel cells.

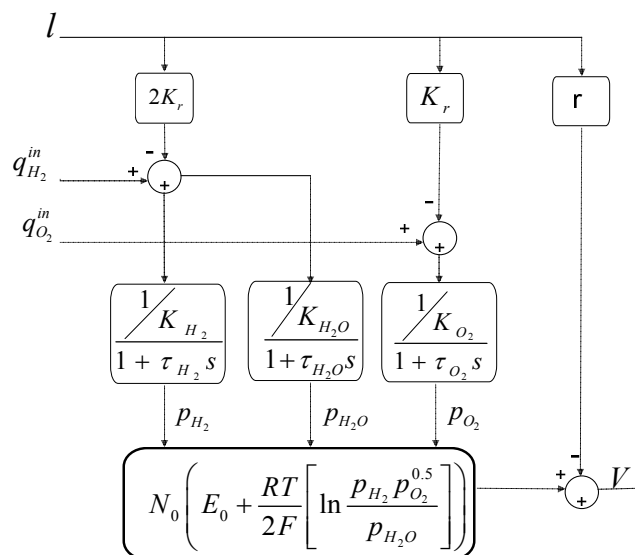

Fig. 1 SOFC stack dynamic model

TABLE I
 CONSTANTS FOR POPULATION

Parameter	Value	Unit
N_0	384	
K_{H_2}	8.43e-4	Kmol/(atm s)
K_{H_2O}	2.81e-4	Kmol/(atm s)
K_{O_2}	2.52e-3	Kmol/(atm s)
τ_{H_2}	26.1	s
τ_{H_2O}	78.3	s
τ_{O_2}	2.91	s
r	0.126	Ω

B. The benefit of fuel cells could consider from ratio of gas flow rate that react and gas flow in of fuel cells which give the following equation.

$$U_f = \frac{q_{H_2}^r}{q_{H_2}^in} \quad (1)$$

In general, around 80-90% of used fuel cells that give the equation as follow:

$$q_{H_2}^r = \frac{N_0 I_{fe}^r}{2F} = 2K_r I_{fe}^r \quad (2)$$

For hydrogen that flow in to fuel cells, the current needed from fuel cells system could definite in the range follow:

$$\frac{0.8q_{H_2}^{in}}{2K_r} \leq I_{fe}^{in} \leq \frac{0.9q_{H_2}^{in}}{2K_r} \quad (3)$$

C. The output of current in the fuel cells system could be measured so the fuel that flow in to fuel cells could be controlled by U_f at 85% as:

$$q_{H_2}^{in} = \frac{2K_r I_{fe}^r}{0.85} \quad (4)$$

D. The highest capacity is ratio of highest energy sending and ratio of power in fuel cells system that only expectation based on the theory with part of use fuel cells. For capability and workload dynamic that should be highest, the p_k should be the highest as possible. This value affect area in fuel cells directly, especially the output constant value. The cost is the limited the constant output value in the range from 130 to 180%. In practical, the limited value is stricted by safety working system. In the protection command that protect from electrolyte compound, the pressure different in fuel cells between hydrogen and oxygen passed through anode and cathode should not less than 4 kPa under normal steady state condition and 8 kPa under transient state condition. Due to the different of fuel cells system that have various highest capacities, the modeling method to obtain the value p_k at fuel cells system should less 170% which means the highest power that send out from fuel cells less than 1.7 times of energy ratio.

E. The reaction occurs in fuel cells is:

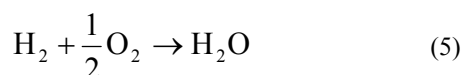

Thus the ratio of combustion between hydrogen and oxygen is 2 to 1. The lots of oxygen will be kept for reaction of hydrogen and oxygen more complete. The simulate model showed that r_{H_2O} should be kept around 1.145 for keeping the pressure in fuel cells under 4 kPa in steady state condition, thus the oxygen that flow in to fuel cells will be controlled for keeping r_{H_2O} at 1.145 by controlling the speed of air compression.

F. The result of chemical reaction in energy process in general is very slow due to connecting to times of conversion chemical parameters after changing flow of substrate in reaction, dynamic function response in chemical reaction will be function in the model stimulate in the first order at time constant at 5 min.

G. Electrical response time in fuel cells would be fast as normal and also related with how fast the chemical reaction rate that good to recovery the ion that be used up by dynamic response function load as transfer function in the first order which there is only constant parameters in time at 0.8 second.

H. In power status, fuel cells system could give the output other than real power that is reaction power in general called PF that could be in the range 1.0-0.8. Because of response time for power status is less than 10 ms, thus it is not necessary to conclude the slow model of fuel cells except the PF could be adjusted by power status.

From data above, dynamic model of SOFC system is shown in Fig. 1 that $q_{O_2}^{in}$ is the oxygen flow in rate [1-4].

The model was created in by Simulink MATLAB program for test the pressure and power values.

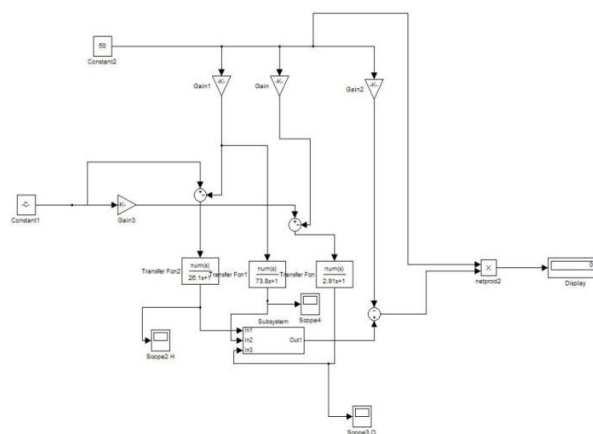

Fig. 2 SOFC model for pressure test

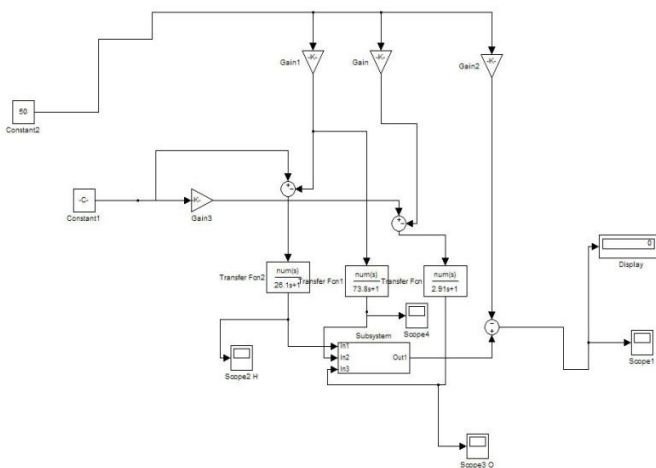

Fig. 3 SOFC model for power test

III. GENERALIZED REGRESSION NETWORKS

A generalized regression neural network (GRNN) is often used for function approximation. It has a radial basis layer and a special linear layer. The architecture for the GRNN is shown below. It is similar to the radial basis network, but has a slightly different second layer [5].

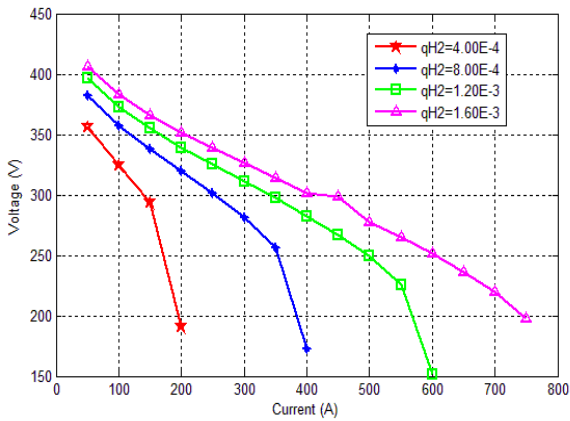

Fig. 4 The relationship of voltage and pressure at steady state condition

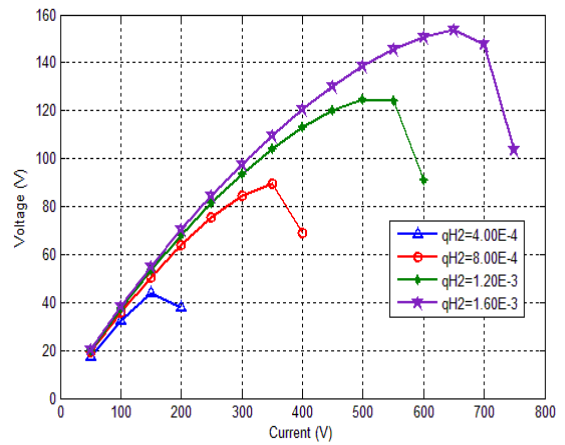

Fig. 7 The relationship of voltage and pressure by GRNN

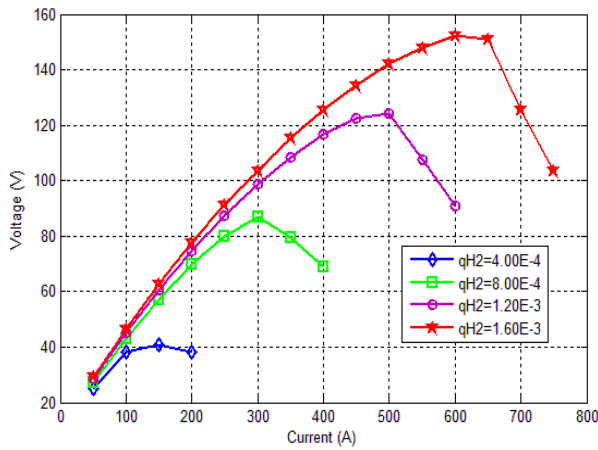

Fig. 5 The relationship of voltage and current at steady state condition

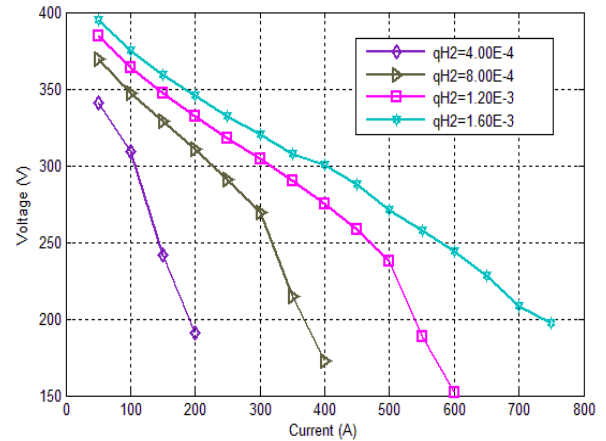

Fig. 8 The relationship of voltage and current by GRNN

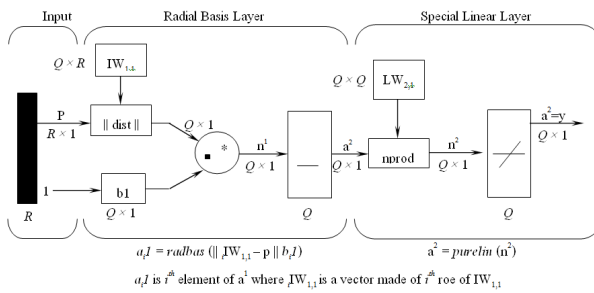

Fig. 6 GRNN flow chart [5]

Where... R = no. of elements in input vector
 Q = no. of neurons in layer 1
 Q = no. of neurons in layer 2
 Q = no. of input/ target pairs

From taking the value from the test from MATLAB Simulink to be fed in GRNN program, the analysis result is shown below.

IV. TEST RESULT AND DISCUSSIONS

The value from GRNN program was compared and shown in the figure below.

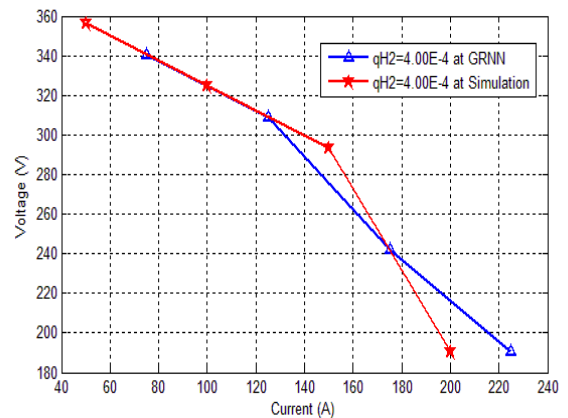

Fig. 9 Comparison of pressure value between simulation and GRNN

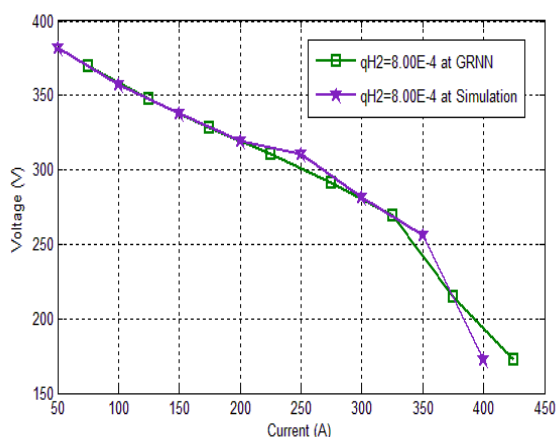

Fig. 10 Comparison of pressure value Simulation and GRNN

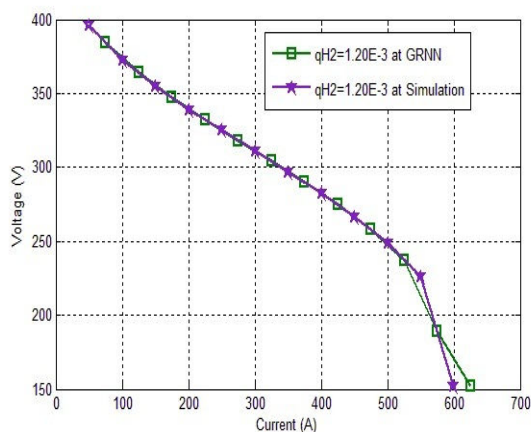

Fig. 11 Comparison of voltage value between Simulation and GRNN

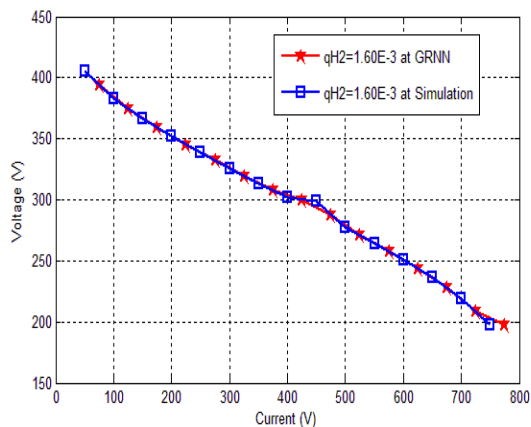

Fig. 12 Comparison of voltage value between simulation and GRNN

In the above figure, the results showed that plot from simulation and GRNN of SOFC fuel cells are the same trend.

TABLE II
THE ERROR VALUE

Voltage (V)	%Error (Voltage)			
	qH ₂ =4.00E-4	qH ₂ =8.00E-4	qH ₂ =1.20E-3	qH ₂ =1.60E-3
50	4.394	3.258	3.056	2.808
100	4.863	2.744	2.361	2.192
150	17.524	2.666	2.252	1.966
200	0	2.832	2.035	1.889
250		3.284	2.167	1.860
300		4.490	2.249	1.871
350		16.341	2.456	1.928
400		0	2.760	0.497
450			3.33	3.582
500			4.69	2.289
550			16.408	2.547
600			0	2.910
650				3.572
700				5.10
750				0

From comparison of the voltage and current value between simulation and GRNN, the value from GRNN is much closed to simulation result. In addition, the graph showed two curves from simulation and GRNN much the same trend also the error value percentage in Table II showed superlative results.

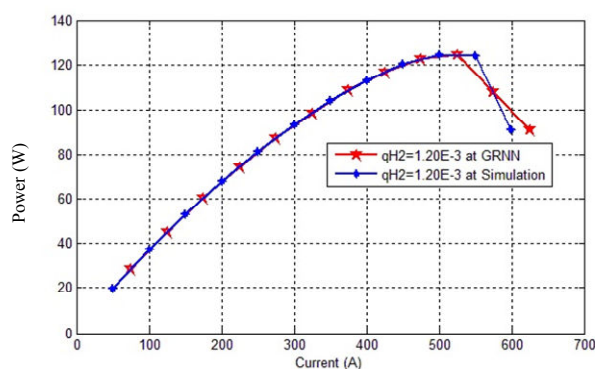

Fig. 13 Comparison of power value between simulation and GRNN

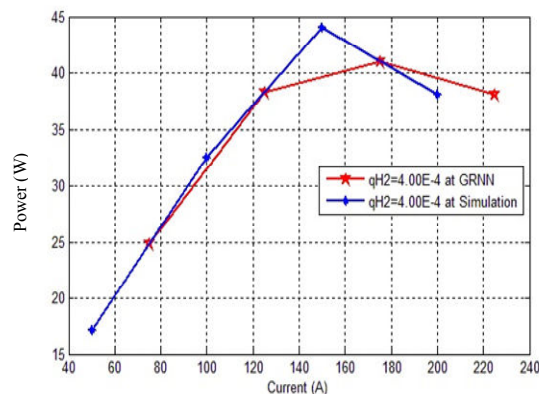

Fig. 14 Comparison of power value between simulation and GRNN

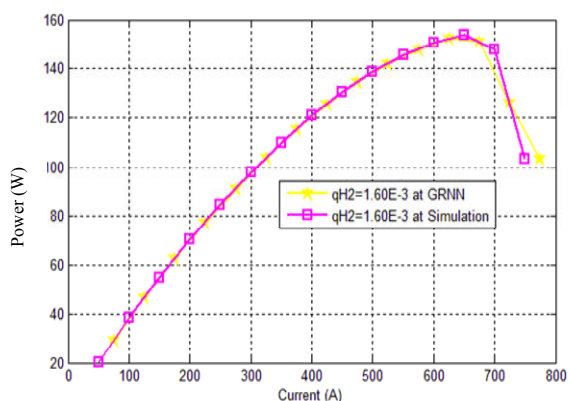

Fig. 15 Comparison of power value between simulation and GRNN

TABLE III
THE ERROR VALUE

Voltage (V)	%Error (Power)			
	qH ₂ =4.00E-4	qH ₂ =8.00E-4	qH ₂ =1.20E-3	qH ₂ =1.60E-3
50	30.823	43.458	44.068	44.06
100	15.036	20.884	21.464	21.72
150	7.16	13.102	13.769	14.030
200	0	8.95	9.846	10.146
250		6.064	7.409	7.767
300		3.106	5.692	6.134
350		11.526	4.326	4.963
400		0	3.185	3.976
450			1.83	3.184
500			0.1605	2.489
550			13.353	1.786
600			0	1.028
650				1.918
700				14.98
750				0

From comparison of the power and current value between simulation and GRNN, the value from GRNN is much closer to simulation result. In addition, the graph showed two curves from simulation and GRNN much the same trend also the error value percentage in Table III showed superlative results.

V. CONCLUSION

The results showed that GRNN is very useful for modeling in SOFC fuel cells system, in addition the voltage value was increased a little but still showed the same trend when compared with simulation results. Finally, the error value was increased little at the beginning and starts to decrease as the pressure value go up.

ACKNOWLEDGMENT

This research work was supported by Research and Development Institute Fund, Suranaree University of Technology, Nakhon Ratchasima, Thailand.

REFERENCES

- [1] Y. Zhu, K. Tomsovic, Development of models for analyzing the load-following performance of microturbines and fuel cells, *Electric Power systems Research* 62 (2002) 1-11.
- [2] Oonsivilai, A. and M.E. El-Hawary: "A Self-Organizing Fuzzy Power System Stabilizer", IEEE. CCECE'98, 1998.
- [3] Oonsivilai, A. and M.E. El-Hawary: "Power System Dynamic Load Modeling using Adaptive-Network-Based Fuzzy Inference System", IEEE. CCECE'99, 1999.
- [4] Oonsivilai, A. and M.E. El-Hawary : "Wavelet Neural Network Based Short Term Load Forecasting of Electric Power System Commercial Load", IEEE. CCECE'99, 1999.
- [5] Satonsaowapak, M., Krapeedang, M., Oonsivilai, R., and Oonsivilai, A. 2010. Gas flow rate identification in biomass power plants by response surface method. *World Academy of Science, Engineering, and Technology*, Paris, France, 27-29 October, pp: 261 – 264.



Nirut Nim-on was born in Sukhothai Province, Thailand, in 1985. He received his B.Eng. in Electrical Engineering from Suranaree University of Technology, Nakhon Ratchasima, Thailand, in 2007. He is currently a graduate student in school of Electrical Engineering, institute of Engineering at the Suranaree University as well. His interesting areas are Fuel Cell Systems and electrical power system.



Anant Oonsivilai was born in Khon Kaen Province, Thailand, in 1963. He received his B. Eng., M. Eng., and Ph. D. from Khonkaen University, King Mongkut Institute of Technology North Bangkok, Thailand and Dalhousie University, Canada, in 1992 and 2000, respectively in Electrical Engineering. Dr. Oonsivilai is currently an Assistant Professor in School of Electrical Engineering, Suranaree University of Technology, Thailand. His areas of interest are electrical power stability, control technology, alternative, and sustainable energy.