

Factorial Structure and Psychometric Validation of Ecotourism Experiential Value Construct: Insights from Taman Negara National Park, Malaysia

Rosidah Musa and Rezian-na Muhammad Kassim

Abstract—The purpose of this research is to disentangle and validate the underlying factorial-structure of Ecotourism Experiential Value (EEV) measurement scale and subsequently investigate its psychometric properties. The analysis was based on a sample of 225 eco-tourists, collected at the vicinity of Taman Negara National Park (TNNP) via interviewer-administered questionnaire. Exploratory factor analysis (EFA) was performed to determine the factorial structure of EEV. Subsequently, to confirm and validate the factorial structure and assess the psychometric properties of EEV, confirmatory factor analysis (CFA) was executed. In addition, to establish the nomological validity of EEV a structural model was developed to examine the effect of EEV on Total Eco-tourist Experience Quality (TEEQ). It is unveiled that EEV is a second-order six-factorial structure construct and it scale has adequately met the psychometric criteria, thus could permit interpretation of results confidently. The findings have important implications for future research directions and management of ecotourism destination.

Keywords—ecotourism, experiential value, experience quality, national park,

I. INTRODUCTION

ECOTOURISM is a growing subsector of the tourism industry and its contributes significantly to economic growth in many less develop countries [1]. Indeed, ecotourism is one of the ‘best-sellers’ subsector of tourism in Malaysia; has been recognized and strongly supported by Malaysian government. It was reported that 35% of the visitors from developed nations came to Malaysia because of its ecotourism site [2]. The growing trend in ecotourism is a result of changing consumer preference for vacation, such as increasing interest in wildlife and nature-based attractions, offers participative educational experience and promotes environmentally and socially responsible travel [1].

In Malaysian context, ecotourism is defined as, “*travel and visitation that is environmentally responsible to relatively undisturbed natural areas in order to enjoy and appreciate nature (including any accompanying cultural features; both past and present), promotes conservation, has low visitor impact and provides for beneficially active socio-economic involvement of local populations*” [3]. There has been quite an extensive ecotourism literature that documents evidence pertaining to the development and management of ecotourism, eco-tourists’ profile, expectation, satisfaction, and motivation [4], [5], [6].

Rosidah Musa is a Deputy Director of the Institute of Business Excellence; Faculty member of Arshad Ayub Graduate Business School, Faculty of Business Management, Universiti Teknologi MARA, 40450 Shah Alam, Selangor, Malaysia (office phone: 603-5521-1946; fax: 603-55211941; e-mail: rosidahm@salam.uitm.edu.my).

Rezian-na Muhammad Kassim, a senior lecturer at the Faculty of Sport Science and Recreation, Universiti Teknologi MARA, 40450 Shah Alam, Selangor, Malaysia. (e-mail: rezian@salam.uitm.edu.my)

However, there is little empirical evidence in the literature that examine implicitly predictors of experiential value associated with ecotourism and its consequences. Therefore, there still remains a gap to examine empirically what are the underlying factors that contribute to the formation of higher order abstraction construct that is experiential value. Particularly in this case a special reference to Taman Negara National Park (hereafter will be referred as TNNP) which is a premier ecotourism site in Malaysia. TNNP encompasses a total area of 4,343 square kilometers, is blessed with extraordinary natural charm of over 130 million years old undisturbed tropical rain forest and a sanctuary of many species of tropical wildlife and wide diversity of fauna and flora. At TNNP, tourists can observe wildlife from a canopy walk or observation huts in the trees. Other attractions include river cruises, jungle-trekking and hiking Mount Tahan (the highest mountain in West Malaysia).

Recently both practitioners and academics have accentuated the important role of experiential value [7], and total customer experience in influencing customer loyalty [8], [9], [10]. The knowledge of the underlying dimensional structure of experiential value in the tourism environment is very critical in developing effective targeting, segmenting and delivering value proposition to the potential eco-tourists. Unequivocally, the effectiveness of tourism and hospitality offerings largely depends on how well travel agencies and tour operators work on nurturing and maintaining loyal customers [11]. The current trend in marketing has gone beyond creating customer loyalty but to formulate engaging and lasting experience for customers [12].

II. LITERATURE REVIEW

Today, the world’s economy has transcended from product and service-base to experience-based [13]. The quality experiences offered to tourists which are memorable, might have positive impact on business’s ability to generate revenue [12]. Although quite a number of researches have addressed consumption experience in the context of retailing and hospitality services, but there is conspicuously very limited research attempt to examine this emerging concept in the tourism setting, with notable exception by the work of Oh, Fiore, and Jeong [14].

This study borrows a well-known environmental psychology theory, S-O-R model by Mehrabian-Russell’s [15]. They postulate the interrelationship between the three variables which are stimulus-organism-response. Following the S-O-R model, this study posits that the environment cues or stimulus influences tourists’ evaluation of value they obtained from the experience in the ecotourism site, which affect their feelings. Subsequently, their affective responses influence their behaviors.

In summary, the environmental cues and interaction touch points are the stimulus (S) that influences emotional states (O), which in turn affect behavioral response (R). In the present research context, Ecotourism Experiential Value (EEV) is the (S) element, while Total Eco-tourist Experience Quality (TEEQ) is the (O) element, which is measured based on three emotional states: pleasure, arousal and dominance (PAD emotions theory). However, it is important to note that only pleasure and arousal emotion states are applicable in the current research context. Additionally, in this paper we do not include the R (response) element because its main focus is to illustrate and confirm the factorial structure of EEV and to validate the psychometric properties of EEV scale.

A. Ecotourism Experiential Value (EEV)

Customers today are seeking for more value, choices and subsequently meaningful and memorable experience. In retailing context [16], [7] have highlighted on the critical role of service experience, and proposed that retailers should focus on creating theatrical retailing environment which involve fun, excitement and entertainment, as well as encouraging greater participation in the retail service experience. Experiential value is defined as “A perceived, relativistic preference for product attributes or services performance arising from interaction within a consumption setting that facilitates or blocks achievement of customer goals or purposes” [17, p. 53]. In the present research context, ecotourism experiential value (EEV) concept is viewed as perceived benefits gained when engaging in the eco-tourism product offerings and services. Broadly speaking, the assessment will be based on the value the eco-tourists gain from visiting TNNP. For instance, we hypothesized that aesthetics value could be derived from the natural beauty of tropical rain forest, uniqueness of the fauna and flora and citing of wildlife in the natural habitat; social bonding experienced when interacting with family and other TNNP visitors; economic value of the vacation will be derived from the quality of services compared with the price paid; enrichment of knowledge when visited this eco-tourism spot and feeling the enjoyment of diverging to a new self when deeply immerse in the ecotourism environment [18], [12]. EEV is conceptualized as experience-based value which comprises of both the utilitarian (extrinsic) and hedonic (intrinsic) value component, thus it is a hierarchical model. Bitner and Brown [19] proposed that level of experience value consumption could influence customer satisfaction and in turn loyalty.

B. Total Eco-tourist Experience Quality (TEEQ)

There is considerably limited literature in the total customer experience research stream and it was noted that this new concept gained popularity through the work of Macarenhas, Kesavan and Bernacchi [9]. The authors assert the vital role of total customer experience in driving a lasting customer loyalty. Further they also advocate the importance of having ‘an emotional involvement’ across all the interaction between the customer and seller. They conceptualized total customer experience as a totally positive, engaging, enduring, and socially fulfilling physical and emotional experience across all major levels of one’s consumption chain [9].

Customer experience is conceptualized as the customer’s affective response when engaging and consuming the product offerings and services. On the other hand, experience quality is viewed as perceived excellence or superiority of the experience [20]. The quality of the experience in the eco-tourist context revolves around every touch points during the interaction with the service provider and the tourism site. Arguably, affective or emotional elements form the basis for assessment of the quality of the service experience. In short, this paper conceptualize total customer experience quality reflects the overall feeling of pleasure (satisfy, enjoyment, delighted) and arousal (excitement, interesting, memorable and unforgettable) in respond to the sense of being served and cared according to his/her expectation or standard, throughout the holistic journey in consuming the ecotourism experience.

III. RESEARCH DESIGN AND METHODOLOGY

Guided by the extant literature review and the methodological procedure suggested by Churchill [21], we designed a research methodology to develop, test and purify a scale to measure the tourists’ assessment of value derived when visiting TNNP. The Experiential Value Scale (hereafter, known as EVS) which is a first-order seven-factor model was introduced by Mathwick et al. [7], has been used as the main reference in developing EEV. The EVS measures consumer return on investment, service excellence, escapism and aesthetic appeal. Later, [16] the scale was validated in the shopping mall industry to demonstrate how experiential value (including efficiency value, aesthetics value, excellence value and playfulness value) affects behavioral intention.

In the present study, EVS scale has been modified and extended to suit the ecotourism setting. Additional items were generated from tourism and hospitality literature. Whereas TEEQ scale was based on PAD theory, which was developed by [15]. The scales utilized in this study are: semantic differential scale (7-point scale), Likert scale (7-point scale: 1 = strongly disagree to 7 = strongly agree) and dichotomous scales.

As no sampling frame is available, probability sampling was ruled out. The sample is restricted to adult visitors of the age of 16 and above. Majority of the respondents who participated in the study were intercepted at the departure points of TNNP. The survey forms were also distributed to hospitality institutions and restaurants in the vicinity of TNNP to achieve desired sample. 250 questionnaires were returned out of the total of 300 distributed. However, due to missing answers only 225 questionnaires were usable for to run relevant data analysis. The response rate is 75%, which is considered high. The respondents were given souvenirs of Malaysia such as batik scarf and handkerchief of batik design as an incentive to encourage participation.

IV. RESULTS

A. Demographics Profile of Respondents

Table I presents the profile of respondents, 55 percent were male, the majority of which fall in the age category of 21 to 40 years are dominant (64 percent). Interestingly, high proportion of the sample comprises of international eco-tourists (93%)

and majority from European countries (46 percent) and 80 percent of the respondents have tertiary education.

TABLE I
 DEMOGRAPHIC PROFILE OF RESPONDENTS

Variable	Description	Frequency	Percentage
Gender	Male	123	54.7%
	Female	102	45.3%
Age	< 20 years old	20	8.9%
	21 – 30 years old	66	29.3%
	31 – 40 years old	79	35.1%
	41 – 50 years old	40	17.8%
	51 – 60 years old	18	8.0%
	> 61 years old	2	0.9%
Highest Academic Achievement	High School	45	20%
	Undergraduate	90	40%
	Post graduate Professional	34	15.1%
Nationality	Malaysian	16	7.1%
	ASEAN	48	21.3%
	European	104	46.2%
	North & South America	16	7.1%
	Africa	2	0.9%
	Australia/New Zealand	12	5.3%
	Far East (China /Japan/ Korea/ Taiwan)	27	12.0%

B. Exploratory Factor Analysis (EFA)

Multi-item measures were subjected to exploratory factor analysis and reliability analyses. The objective of exploratory factor analysis is to find a set of underlying latent constructs, which might be represented by a set of items. An exploratory factor analysis using maximum likelihood estimation was first conducted to assess the dimensionality of the scales. Two exploratory factor analyses (EFA) were conducted separately on Ecotourism Experiential Value (Table II) and Total Ecotourist Experience Quality (Table III). The EFA used principal components extraction with varimax rotation. It is the most commonly used analytical technique for reducing a large item pool to a more manageable set. It is recognized to be a valuable preliminary analysis when no sufficient theory is available to establish the underlying dimensions of a specific construct as recommended by Gerbing and Anderson [22]. In order to achieve a more meaningful and interpretable solution in the iterative process items with low factor loadings (< 0.5) or high cross-loadings (> 0.3) were removed and EFA was performed again as recommended by [23].

The first EFA was performed to assess the factor structure of EEV measurement scale which comprises of 30 items. However, this initial purification exercise resulted in the deletion of ten items because of failing to fulfil the above-mentioned criteria. Subsequently, EFA with the remaining 20 items was performed, which resulted in a six-structure solution: F1: Aesthetic; F2: escapism; F3: social; F4: service; F5: economy and F6: knowledge enrichment.

Table II displays the final results of EFA which unravel the six dimension of ecotourism experiential value. The factor loadings for the 20 items ranged from 0.50 to 0.81, well above the threshold value of 0.35 for practical and statistical significance. The loadings also presented a clean and highly interpretable solution, a 'simple structure' according to [19].

The result reveals both Bartlett test of sphericity (2060.49 at $p = 0.001$) and the Kaiser-Meyer-Olkin measure of sampling adequacy (KMO = 0.883). These indicate that there was sufficient inter-item correlation with the data for performing factor analysis. Sharma [24], suggests that the cut-off level for the Kaiser-Mayer statistic should be greater than 0.8, but that a value of 0.6 is tolerable. The six-factor solution was extracted with Eigenvalues greater than 1. The result depicts that the Alpha coefficients of the six factors ranged from 0.50 to 0.85.

TABLE II
 FINAL EXPLORATORY FACTOR ANALYSIS FOR ECOTOURISM EXPERIENTIAL VALUE

Ecotourism Experiential Value	F1	F2	F3	F4	F5	F6
1. peaceful and restful atmosphere	0.71					
2. truly tropical rainforest paradise	0.72					
3. wilderness of the national park thrills me	0.74					
4. scenic landscape excite me	0.75					
5. beauty of this park is aesthetically pleasing	0.61					
6. tour guides are knowledgeable					0.79	
7. tour guides are helpful and friendly					0.85	
8. activities competently organized					0.70	
9. enjoy socializing with others					0.79	
10. opportunities to make friends who share the same interest					0.80	
11. learn and participate in the local culture and traditional activities					0.57	
12. cost of this trip is considered reasonable					0.78	
13. my money's worth spent for this vacation					0.65	
14. overall cost of this trip is of economic value					0.78	
15. expands my knowledge					0.81	
16. opens my eyes to a whole new level					0.59	
17. feel like I am in a different world	0.72					
18. so involved that I forget everything else	0.75					
19. this vacation "gets me away from it all"	0.77					
20. jungle trekking and hiking challenging	0.50					

The second EFA was performed on TEEQ, which consists of 10 items. As expected two factor solution was extracted; however, the initial purification exercise resulted in deletion of four items. Table III displays the result for both Bartlett test of sphericity (862.99 at $p = 0.001$) and the Kaiser-Mayer-Olkin measure of sampling adequacy (KMO = 0.86). This indicates that there are sufficient inter-item correlations with the data for performing factor analysis [24]. In the initial purification exercise, 2 items were removed on the basis of low factor loadings (< 0.50). The result of final EFA produces two-factor structures with relatively high factor loadings and Eigenvalues greater than 1. The Alpha coefficients of the two factors ranged from 0.7 to 0.91. It is important to note here that Cronbach's alpha, the customary index of reliability, was assessed after unidimensionality of a measure has been established; this was in line with the suggestion proposed by [22]. A commonly used threshold value of 0.70 as recommended by Nunnally and Bernstein [25] was utilised; however Hair et al. [20] suggest that values slightly below 0.70 are acceptable if the research is regarded as exploratory.

TABLE III
 FINAL EXPLORATORY FACTOR ANALYSIS FOR TOTAL ECO-TOURIST
 EXPERIENCE QUALITY

Total Eco-tourist Experience Quality Items	Pleasure (F1)	Arousal (F2)
1. disappointed – delighted	0.91	
2. not enjoyable – enjoyable	0.83	
3. unsatisfied – satisfied	0.82	
4. unmemorable – memorable		0.70
5. boring – interesting		0.71
6. forgettable – unforgettable		0.84

C. Confirmatory Factor Analysis

Gerbing and Anderson [22] argue that item-total correlation, alpha coefficient and exploratory factor analysis (EFA) procedures could not ensure unidimensionality of measures, which is viewed as an important requirement of valid measurement. They strongly recommend that a more rigorous statistical procedure be employed to refine and confirm the factor structure generated from the initial EFA. Confirmatory factor analysis (CFA) has been proposed as an analytical tool to ascertain unidimensionality of measures. Hence, in line with this suggestion, all the resulting factor structures derived from two EFA were tested and validated by confirmatory factor analysis (CFA) analytic procedure, which tests *a priori* factor structure and goodness of fit of the resulting solution (Kline, 1998). CFA was carried out using AMOS 18 analytical program developed by Arbuckle and Wothke [28].

To achieve an acceptable ratio of observations to estimate parameters, it proved necessary to run two separate measurement models which are EEV and TEEQ. The first measurement model consists of EEV construct which comprises of six-factor solution. The appropriateness of the measurement model described by CFA was assessed using the chi-square statistic, a set of relative fit indices. A significant chi-square statistic indicates lack of fit between the data and the model. However, a highly restrictive test required by chi-square statistic mostly leads rejection of the proposed model. Hence, most researchers will resort to other absolute and relative fit indices to infer validity of the proposed model. The Goodness of Fit Index (GFI) is analogous to squared multiple correlations (R^2) in multiple regressions. Comparative fit index (CFI) indicates the overall fit of the model relative to a null model, and Normed Fit Index (NFI) adjusts for the complexity of the model. These fit measures being close to 0.90, the recommended cut-off criterion [26], [27]. Root mean square error of approximation (RMSEA) indicates the approximation of the observed model to the true model, with lower RMSEA suggesting better model. The model fit results supports a 18-item, 6-dimensional scale for Ecotourism Experiential Value (EEV).

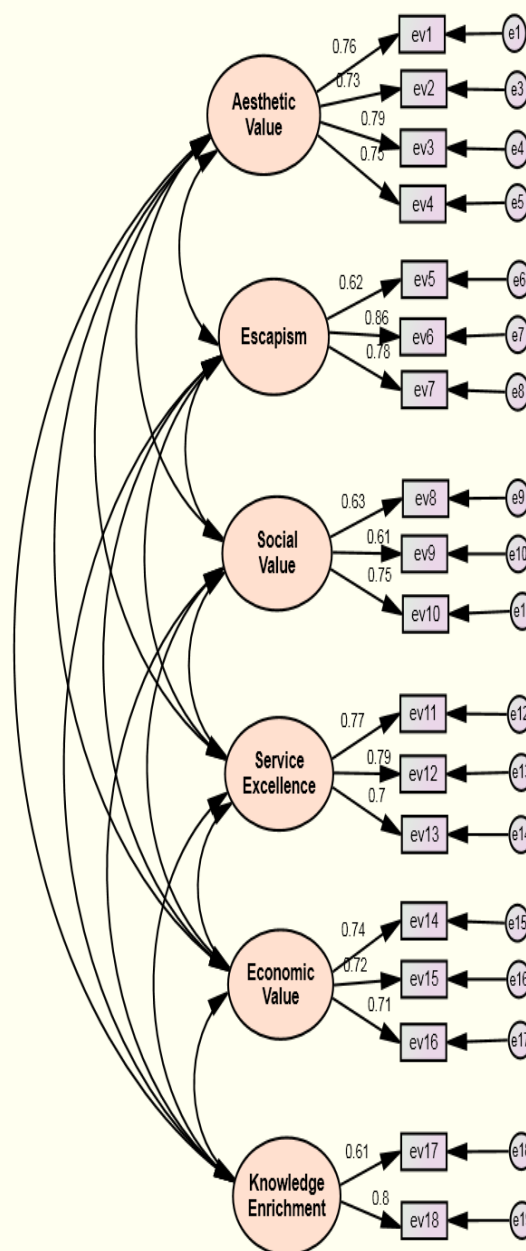

Fig. 1 Results of confirmatory factor analysis for revised first-order six factor model of (EEV)

Figure 1 visually presents the factorial structure of EEV and explicate the path coefficient of each indicator on the corresponding factor. The results of the first measurement model are as follows: the fit statistics were $\chi^2 = 227.15$, $df = 118$, $\chi^2/df = 1.93$, $p < 0.001$; $RMR = .063$; $GFI = 0.90$; $IFI = 0.94$; $CFI = 0.94$; and $RMSEA = 0.064$. All indicators loaded heavily on the factor/dimension and have t-values greater than 7.73 and all standardised coefficient are greater than 0.50. The result support a 18-item, 6-dimensional scale for Ecotourism Experiential Value (EEV).

TABLE IV
 SUMMARIZED RESULTS OF ECOTOURISM EXPERIENTIAL VALUE
 MEASUREMENT MODEL

EEV Dimensions	F1	F2	F3	F4	F5	F6
Aesthetics value (F1)	0.59					
Escapism (F2)	0.52	0.73				
Social value (F3)	0.40	0.45	0.59			
Service excellence (F4)	0.49	0.32	0.33	0.65		
Economy value (F5)	0.53	0.44	0.34	0.41	0.51	
Knowledge (F6)	0.53	0.49	0.43	0.43	0.37	0.59
Mean score	5.75	5.48	5.23	5.60	5.54	5.58
Standard Deviation	0.74	0.94	1.09	0.87	0.89	0.92
Cronbach's Alpha	0.85	0.78	0.76	0.79	0.77	0.65
Composite Reliability	0.85	0.94	0.89	0.90	0.84	0.81

Note: Average Variance Extracted (AVE) is presented on the diagonal axis

Table IV illustrates the results of the six-dimension EEV measurement model, which include correlation matrix, mean value, Cronbach's alpha, composite reliability and Average Variance Extracted (AVE). Construct reliability was also assessed by estimating the AVE, which reflects the overall amount of variance captured by the latent construct and Composite Reliability (CR). CR reflects the internal consistency of the construct indicators, while AVE reflects the amount of variance captured by the construct indicators [20]. All CR scores ranging from 0.81 – 0.94, were much higher than the recommended cut-off point of 0.7 [29]. Thus, each of the factors reliably measured its respective constructs. The AVE scores ranged from 0.51 to 0.73, exceeding the recommended cut-off point of 0.5 as suggested by Fornell and Larcker [30].

Construct validity was assessed in terms of convergent and discriminant validity. Convergent validity is established through high correlations between the measure of interest and other measures that are supposedly measuring the same concept [31]. The critical ratio (t -value) of the items in the two measurement models exceed ± 1.96 or ± 2.58 at 0.05 or 0.01 levels respectively and standardized factor loading of 0.5 and above. Hence, substantiate the convergent validity of the constructs [32]. Alternatively, discriminant validity can also be established through low correlations between the constructs and it is evident, when the correlation between factors was lower than 0.80 [33]. In the present study, the discriminant validity is achieved as the correlation coefficients ranging from 0.32 to 0.53. In addition, for a rigorous test of discriminant validity the AVE of each construct was computed and found to be greater than the squared correlation between the construct and any other constructs in the model (Table IV) as recommended by Fornell and Larcker, [30].

A complementary assessment of discriminant validity is to determine whether confidence interval of (± 2 standard errors) around the correlation estimated for each pair of constructs includes 1 as suggested by Anderson and Gerbing [32]. The result illustrates that this criteria has been achieved satisfactory. In conclusion, it is reasonable to claim that all the measures used in the study possess good psychometric properties.

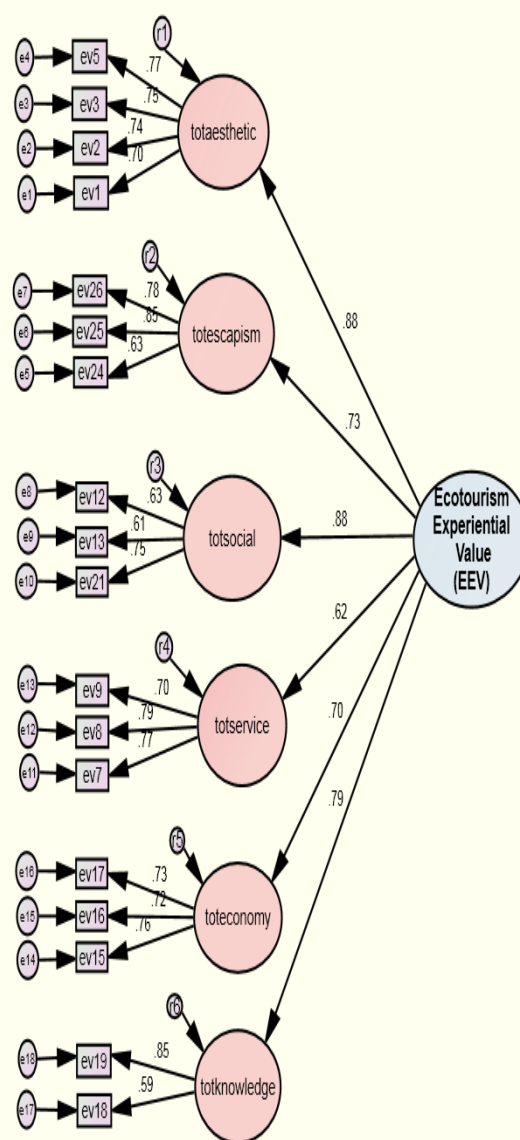

Fig. 2 Results of confirmatory factor analysis for the second order six-factor model of EEV

D. Testing an alternative model: second-order six-factor model of ecotourism experiential value (EEV)

The first-order model of EEV implies that the six-factors – aesthetics value, escapism, social value, service excellence, economy value and knowledge enrichment – are correlated, but govern by a common latent factor. Alternatively, EEV model may be operationalized as a second-order model, of which the six factors are governed by a higher-order factor, i.e. Ecotourism Experiential Value. Confirmatory factor analysis was performed in order to assess if the EEV model has a higher order construct explained by a number of related dimensions. This procedure was an effort to achieve strong validity and reliability [34], [13], [35]. As shown in Figure 2, the second-order standardized factor loadings of EEV Model are 0.88 for aesthetics, 0.73 for escapism, 0.88 for social, 0.62 for service, 0.70 for economy, and 0.79 for knowledge

enrichment. The overall model statistics for EEV second-order model produced a good fit with the data well. The fit statistics were $\chi^2(124) = 204.68$, $p < 0.001$ ($\chi^2/df = 1.65$, $RMR = .064$; $GFI = 0.91$; $IFI = 0.95$; $CFI = 0.95$; and $RMSEA = 0.054$). All indicators loaded heavily on the factor/dimension and have t -values greater than 7.73 and all standardized coefficient are greater than 0.50. The results support a 18-item, 6-dimensional scale for EEV.

TABLE V
 COMPARISON OF OVERALL FIT INDICES OF TWO MODELS OF EEV

Models	χ^2	df	χ^2/df	GFI	RMSEA	CFI	$\Delta \chi^2$
First-order six-factor model	227.15	118	1.93	0.90	0.064	0.94	
Second-order six-factor model	204.68	124	1.65	0.91	0.054	0.95	22.47

Table V demonstrates the overall fit indices for the first-order and second-order of EEV models. The results imply that both models fit the data satisfactorily. However, the second-order six-factor model outperformed the first order six-factor model. The χ^2 difference test indicates that the improvement in fit between the first-order and second-order seven-factor model of EEV was statistically significant, $\Delta \chi^2(6) = 22.47$, $p < 0.001$. This result indicates that the second-order model outperformed the first-order model, provides the best representation of data in this study.

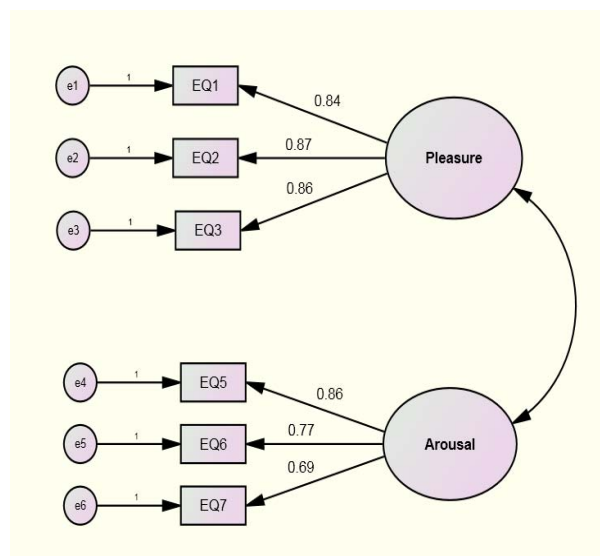

Fig. 3 Measurement Model for TEEQ

Fig 3 illustrates visually the factorial structure of the second measurement model. In view to achieve an acceptable ratio of observations to estimate parameters, it proved necessary to run a second measurement model for TEEQ. The fit indices suggest that the model fit the data well. The TEEQ measurement model is of two-factor structure, which consists of three indicators for pleasure dimension and three indicators for arousal. The fit statistics were $\chi^2 = 18.47$, $df = 11$, $CMIN/df = 1.68$, $p < 0.071$; $RMR = 0.039$; $GFI = 0.97$; $AGFI = 0.95$; $IFI = 0.99$; $CFI = 0.99$; and $RMSEA = 0.055$.

All the six items loaded heavily on their respective factors and the standardized coefficients are greater than 0.50, above the recommended level of 0.5 by Bagozzi and Yi [36]. Therefore, all the six items were retained for nomological validity assessment using structural equation modelling subsequently.

TABLE VI
 SUMMARIZED RESULTS OF TOTAL ECO-TOURIST EXPERIENCE QUALITY MEASUREMENT MODEL

EEV Dimensions	F1	F2
Pleasure (F1)	0.59	
Arousal (F2)	0.65	0.71
Mean score	5.99	5.87
Standard Deviation	0.96	0.89
Cronbach's Alpha	0.89	0.85
Composite Reliability	0.93	0.89

Note: Average Variance Extracted (AVE) is presented on the diagonal axis

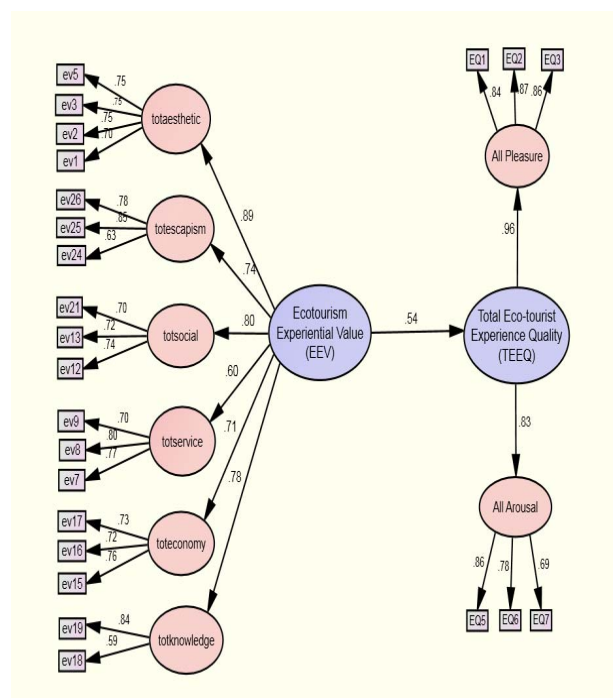

Fig. 4 Nomological validity assessment using Structural Equation Modeling

To establish the nomological validity of the EEV scale, the present study relies on its capability in explaining relationship of EEV with other construct as stipulated in the past literature. In this context, we used previously established relationship of EEV with TEEQ [9], [4]. The results of the analysis are diagrammatically presented in Figure 4. Evidence of nomological validity of EEV scale was assessed by testing the structural relationships between EEV and the consequence construct, TEEQ. To test the structural model, the second-order model of EEV (Fig 2) was transferred to the first-order model via the model of "parcelling" (Fig 4). This was achieved by using composite scores for each dimension, which was calculated by averaging the items measuring each dimension of EEV. This is a common practice among researchers [37], [35].

The results of the overall fit of the structural model was good ($\chi^2 = 407.28$, $df = 238$, $\chi^2/df = 1.71$, $p = 0.001$; RMR = 0.069; GFI = 0.87; IFI = 0.94; CFI = 0.94; and RMSEA = 0.056). More importantly, the path coefficient for the effect of EEV on TEEQ was significant ($\beta = 0.51$; $t = 5.79$; $p < 0.01$). The estimates substantiate the nomological validity of EEV.

V. CONCLUSION

The results of this research afford three major contributions. First, EFA illustrates the factor structure or dimensionality of EEV construct. Six factors were unveiled: aesthetics value, escapism, social, service, economy value, and knowledge enrichment. By performing EFA, items of EEV scale were refined to 20 items from 30 items. CFA provides a more rigorous estimation than EFA, suggests that 2 items have to be dropped in order to improve the model fit. The final EEV construct comprises of 18 items. The 18-item construct is a reliable and valid measure to determine the underlying factorial structure of EEV.

Second, convergent validity and discriminant validity were upheld by factor loadings and correlations between factors in CFA model respectively. Subsequently, CFA establishes that second-order six-factor model of EEV provides the best representation of the data in this research enquiry. This study provides evidence that EEV construct is multi-dimensional and of hierarchical structure. In essence, there is evidence that EEV is a multidimensional construct which is consistent with the prior literature [7] and furthermore, it possesses satisfactory psychometric properties.

Thirdly, it is worthy to note that EVS which was developed by [7] and has been applied in the catalog and Internet shopping environment as well as a traditional brick-and-mortar retail setting [15]. The present study is the first to validate the modified version of EVS in tourism context. It is unveiled that EEV is a six-factor model, whereas EVS is a seven-factor construct. It should be noted that entertainment, efficiency and enjoyment dimensions of EVS were found irrelevant in the present setting. The present investigation has identified two new dimensions which are: social value and knowledge enrichment. Emergence of these two dimensions seems consistent with prior literature in the tourism research strand.

Undoubtedly EEV can be a valuable tool to help managers and tour operators to develop a customer typology based on the experiential value dimensions. For instance, the hedonists may prefer the aesthetics, escapism, and social interaction provided by the eco-tourist site. On the other hand, the utilitarian segment may mainly appreciate ecotourism destination that offers economic value, excellence service, and capable of offering knowledge enrichment. Apparently, managers can create value proposition based on eco-tourist typology. By doing so, they are able to design their tourism product offerings to their target client effectively. In fact by managing their customer experience effectively, this may lead to the great and memorable experience, which is much sort after by customers today.

This study focuses exclusively on one specific eco-tourist destination in Malaysia. Therefore, caution should be

exercised in generalizing the results to other tourism sector. Replication studies must be undertaken to validate the findings using different ecotourism environments and also across other geographical areas. In addition, the research design of using questionnaires and statistical method of analysis is often criticized in assessing the experiential aspect of consumption. The preliminary investigation might provide rich insights by qualitative research approach, such as in-depth interviews and focus group discussion in future research. An interesting avenue for future research is to investigate the effect of EEV on tourist attachment and engagement behavior by conducting longitudinal research design. Perhaps, this potential research endeavor could afford more insightful findings.

ACKNOWLEDGMENT

The authors would like to thank The Ministry of Higher Education of Malaysia for providing the Fundamental Research Grant Scheme (FRGS) and Universiti Teknologi MARA, for providing assistance and facilitating this research.

REFERENCES

- [1] T. H. Parks, T. A. Parks and C. Allen, "The development of a framework for studying ecotourism", *International Journal of Management*, vol. 26, no. 1, pp. 89, April 2009.
- [2] The Star, "Eco-tourism best-seller in sector, says minister", 12/12/2003.
- [3] WorldWide Fund for Nature Malaysia "National Ecotourism Plan, Part 2 – Ecotourism Potential: Site listings", *A Study prepared for The Ministry of Culture, Arts and Tourism, Malaysia, 1996*.
- [4] R. Musa et al., "Factorial Validation of Ecotourism Destination Image and Eco-tourists' Motivation: Empirical Analysis of Taman Negara National Park (TNNP), Malaysia (Published Conference Proceedings ISBN 978-1-906638-65-8)," in 9th *European Conference in Research Methods in Business and Management Studies*, Madrid, Spain, 2010.
- [5] V. Palacio, V. and S. McCool, S. "Identifying ecotourists in Belize through benefit segmentation: A preliminary analysis", *Journal of Sustainable Tourism*, vol 5, no. 3, pp. 234-243, 1997.
- [6] P. W. William (1992) "A local framework for ecotourism development", *Western Wildlands*, vol 18, no 3, pp. 14-19, 1992.
- [7] C. Mathwick, N. Malhotra, and E. Rigdon, "Experiential value: conceptualization, measurement and application in the catalog and internet shopping environment", *Journal of Retailing*, vol. 77, no. 1, pp. 39-56, 2001.
- [8] L. L. Berry, L. P. Carbone and S. H. Haeckel, "Managing the total customer experience", *Sloan Management Review* 43, pp. 85-89, 2002.
- [9] O. A. Mascarenhas, R. Kesavan, and M. D. Bernacchi, "Lasting Customer Loyalty: A total Customer Experience Approach", *Journal of Consumer Marketing*, vol. 23, no. 7, pp. 397-405, 2006.
- [10] R. Musa, L. Putit, and R. Kassim, "Disentangling Sport Event Experiential Value (SEEV): F1 – Petronas Malaysia Grand Prix's Evidence", *Journal of International Business and Entrepreneurship*, vol. 14, no. 2, pp. 1-18, 2009.
- [11] S. J. Backman, and J. L. Crompton, "The usefulness of selected variables for predicting activity loyalty", *Leisure Sciences*, vol. 13, pp. 205-220, 1991
- [12] B. J. Pine and J.H. Gilmore, *The experience economy*, Harvard Business School Press, Boston, 1999.
- [13] J. H. Kim, J. R. B. Ritchie, and B. McCormick, "Development of a scale to measure memorable tourism experiences", *Journal of Travel Research*, vol. 51, no. 1, pp. 12-25, 2012.
- [14] H. Oh, A. M. Fiore, and M. Jeong, (2007). "Measuring experience economy concepts: tourism applications", *Journal of Travel Research*, vol. 46, pp. 119-131, 2007.
- [15] A. Mehrabian and J. A. Russell, "The Basic Emotional Impact of Environments", *Perceptual and Motor Skill*, 38, pp. 283-301, 1974.

- [16] C. J. Keng, T. L. Huang, L. J. Zheng, and M. K. Hsu, "Modeling service encounters and customer experiential value in retailing: An empirical investigation of shopping mall customers in Taiwan" *International Journal of Service and Industry Management*, vol. 4, pp. 349-367, 2007.
- [17] C. Mathwick, N. Malhotra, and E. Rigdon, "The effect of dynamic retail experiences on perception of value: an Internet and catalog comparison", *Journal of Retailing*, vol. 78, pp. 51-60, 2002.
- [18] M. J. Bitner, W. Faranda, A. Hubbert, and V. Zeithaml, "Customer Contributions and Roles in Service Delivery", *International Journal of Service Industry Management* vol. 8, no. 3, pp. 193-205, 1997.
- [19] M. J. Bitner and S. W. Brown, "Technology infusion in service encounters", *Journal of Academy of Marketing Science*, vol. 28, no. 1, pp. 138-149, 2000.
- [20] F. Lemke, M. Clark, and H. Wilson, "Customer experience quality: an exploration in business and customer contexts using repertory grid technique", *Journal of the Academy Marketing Science*, published online 07 September, 2010.
- [21] G. A. Churchill, "Paradigm for developing better measures of marketing constructs", *Journal of Marketing Research*, vol. XV1, pp. 64-73, 1979.
- [22] D. W. Gerbing, and J. C. Anderson, "An updated paradigm for scale development incorporating unidimensionality and its assessment", *Journal of Marketing Research*, vol. 25, pp. 186-92, May 1988.
- [23] J. Hair, W. B. Babin and R. Anderson, *Multivariate Data Analysis* Prentice-Hall Upper Saddle River, NJ, 2010.
- [24] S. Sharma, *Applied Multivariate Techniques*. John Wiley and Sons Inc., New York, 1996.
- [25] J. C. Nunnally and I. Bernstein, *Psychometric Theory*, 3rd ed. New York: McGraw-Hill, Inc., 1994.
- [26] P. Betler, and D. Bonett, "Significance tests and goodness-of-fit in the analysis of covariance structures", *Psychological Bulletin*, vol. 88, no. 3, pp. 588-606, 1980.
- [27] K. A. Bollen, *Structural Equations with Latent Variables*, Wiley, New York, NY, 1989.
- [28] J. L. Arbuckle, and W. Wothke, *Amos 4.0 user's guide*. Chicago, IL: SPSS, 1999.
- [29] F. Olorunniwo, M. K. Hsu, and G. J. Udo, "Service quality, customer satisfaction, and behavioural intentions in the service factory", *Journal of Services Marketing*, vol. 20, no. 1, pp. 59-72, 2006.
- [30] C. Fornell, and D. F. Larcker, "Evaluating structural equation models with unobservable variables and measurement error", *Journal of Marketing Research*, vol. 18, pp. 39-50, February 1981.
- [31] D. A. Aaker, V. Kumar, and G. S. Day, *Marketing Research* (Ninth Edition), John Wiley & Sons, 2007.
- [32] J. C. Anderson and D. W. Gerbing, "Structural Equation Modeling in Practice: A Review and Recommended Two-Step Approach", *Psychological Bulletin*, vol 103, no 3, pp. 411-423, 1988.
- [33] R. B. Klien. *Principles and Practice of Structural Equation Modeling*. 2nd ed. The Guilford Press, New York, 2005.
- [34] M. Browne and R. Cudek, "Alternative ways of assessing model fit", in Bollen, K. and Long, J. (Eds), *Testing structural equation models*, Sage, Newbury Park, CA, pp. 136-162, 1993.
- [35] N. A. Omar, and R. Musa, "Measuring service quality in retail loyalty programmes (LPSQual): Implications for retailers' retention strategies", *International Journal of Retail & Distribution Management*, vol. 39, no. 10, pp. 759-783, 2011.
- [36] R. P. Bagozzi, and Y. Yi, "On the evaluation of structure equations models", *Academic of Marketing Science* vol. 16, no. 1, pp. 76-94, 1988.
- [37] K. Roberts, S. Varkie, and R. Brodie, "Measuring the quality of relationships in consumer services: an empirical study", *European Journal of Marketing*, vol. 37, pp. 169-196, 2003.



Associate Professor Dr Rosidah Musa is currently the Deputy Director of Institute of Business Excellence and Head for Halal Business and Science Center at the Faculty of Business Management, Universiti Teknologi MARA, Malaysia. She is also a faculty member of Arshad Ayub Graduate Business School. She holds a PhD in Marketing from Cardiff University, Wales, United Kingdom; MBA from New Hampshire College, USA and B.Sc. (Business Administration) from Indiana State University, USA. Her research interests are: experience quality, brand experience, experiential value, loyalty program, student experience and engagement, pathological Internet use, and Halal marketing and branding strategy. She managed to secure numerous research grants, from the Ministry of Higher Education of Malaysia. She also actively involves in consultation project for Ministry of Agriculture of Malaysia and retail organizations in developing and tracking customer satisfaction index just to name a few. She has presented several papers at national and international conferences, also has published papers in international journals. She has 23 years of working experience in the academic world and teaches mainly marketing and retailing courses at undergraduate as well as postgraduate levels.



Rezia-na Muhammed Kassim is a senior lecturer at the Faculty of Sport Science and Recreation at Universiti Teknologi MARA (UiTM), Malaysia. She specializes in Sport Tourism, Sport Marketing and Spectators Behavior. A graduate of Universiti Teknologi MARA, she received her MBA and DBA degrees from UiTM. Since 1999, she has been actively involves in research related to sport tourism, specifically in the context of Formula One Grand Prix. She is an active member of the Malaysian Sport Tourism Council for more than 15 years. Her main area of research interest is sport tourism, spectator experience and sport marketing. Currently she holds a post as Academic Coordinator of Flexible Learning Program. She has presented several papers in national and international conferences.