

# An Improved Performance of the SRM Drives Using Z-Source Inverter with the Simplified Fuzzy Logic Rule Base

M. Hari Prabhu

**Abstract**—This paper is based on the performance of the Switched Reluctance Motor (SRM) drives using Z-Source Inverter with the simplified rule base of Fuzzy Logic Controller (FLC) with the output scaling factor (SF) self-tuning mechanism are proposed. The aim of this paper is to simplify the program complexity of the controller by reducing the number of fuzzy sets of the membership functions (MFs) without losing the system performance and stability via the adjustable controller gain. ZSI exhibits both voltage-buck and voltage-boost capability. It reduces line harmonics, improves reliability, and extends output voltage range. The output SF of the controller can be tuned continuously by a gain updating factor, whose value is derived from fuzzy logic, with the plant error and error change ratio as input variables. Then the results, carried out on a four-phase 6/8 pole SRM based on the dSPACE1104 platform, to show the feasibility and effectiveness of the devised methods and also performance of the proposed controllers will be compared with conventional counterpart.

**Keywords**—Fuzzy logic controller, scaling factor (SF), switched reluctance motor (SRM), variable-speed drives.

## I. INTRODUCTION

As the development of high speed microcontrollers with powerful computation capability, switched reluctance motor (SRM) drives are under consideration in various applications requiring high performance. SRMs inherently feature numerous merits like simple and rugged structure, being maintenance free, high torque-inertia ratio, fault-tolerance robustness and reliability, high efficiency over a wide range of speeds, etc. The requirements for variable-speed SRM drives include good dynamic and steady-state responses, minimum torque ripple, low-speed oscillation, and robustness. However, due to the heavy nonlinearity of the electromagnetic property and the coupling relationships among flux linkage, torque, and rotor position, it is not easy for an SRM to get satisfactory control characteristics. Therefore, new structure designs [1], high performance magnetic cores [2]. Intelligent control techniques such as fuzzy logic control (FLC), neural network control, or genetic algorithm may allow better performance.

Intelligent control approaches try to imitate and learn the experience of the human expert to get satisfactory performance for the controlled plant [3]. One of the most powerful tools that can translate linguistic control rules into

practical operation mechanism is the FLC. It has been shown that fuzzy control can reduce hardware and cost and provide better performance than the classical PI, PD, or PID controllers [5]. Recently, fuzzy control theory has been widely studied, and various types of fuzzy controllers have also been proposed for the SRM to improve the drive performance further [3],[6]–[8]. Performance of the FLC are scaling factor (SF) tuning, rule base modification, inference mechanism improvement, and membership function redefinition and shifting. The initial parameters and scaling gains of the controller are optimized by the genetic algorithm to minimize overshoot, settling time, and rising time. An adaptive fuzzy controller for torque-ripple minimization is presented by Mir et al. [4]. Aiming at torque-ripple minimization, the controller is independent from the accurate SRM model and can adapt to the change of motor characteristics. These characteristics include position error robustness, avoidance of negative torque production, and torque-ripple minimization. This study was aimed at reducing the torque ripple and acoustic noise by an efficient fuzzy control algorithm. An adaptive FLC with scaling gain tuning is proposed in [7]. The universe of discourse (UOD) of the fuzzy sets can be tuned by altering the scaling gain according to the input variables. This significantly improves the system transient and steady-state responses. Koblara proposed a fuzzy logic speed controller for SRM drives [8]. Fuzzy controller can produce smooth torque and improve the system performance. Z-source inverter system for adjustable speed drives (ASD) [10]. It can produce any desired output ac voltage, even greater than the line voltage. It reduces line harmonics, and extends output voltage range. ZSI is designed suitable for wind power conversion system [9]. The main challenge in wind power system to maintain a constant voltage at the output with unpredictable variation in wind speed, is suitably taken care in steady state through buck-boost-capability of (ZSI). The most concerning disturbances affecting the quality of the power in the distribution system are voltage sag/swell [11]. The ZSI uses an LC impedance grid, prepares the possibility of voltage buck and boost by short circuiting the inverter legs. Additionally a fuzzy logic control scheme for Z-source inverter based DVR is proposed to obtain desired injecting voltage.

Hari Prabhu is with Department of Power Electronics and Drives, in Paavai College of Engineering Namakkal, Tamil Nadu, India. Affiliated to Anna University-Chennai (e-mail: hariprabhum@gmail.com).

## II. SRM DRIVE SYSTEM

### A. SRM Behavior Model

In SRM, the torque is generated due to the push-pull between reluctance forces. The produced electromagnetic torque is related to the variation of the machine coenergy, and the coenergy varies with the flux linkage, excitation current, and rotor position. The flux linkage, inductance, and torque are highly coupled and nonlinear with the variation of rotor position and phase current. Figs. 1 (a) and (b) shows the cross-sectional profile of a four-phase 6/8-pole SRM and the equivalent circuit of one phase winding, respectively.

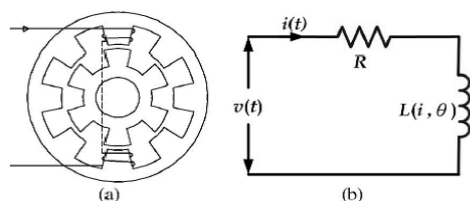

Fig. 1 (a) Cross-sectional profile and (b) equivalent circuit of a 6/8-pole SRM

The equivalent circuit can be represented by a resistance  $R$  in series with an inductance  $L(i, \theta)$ , which is a function of rotor position  $\theta$  and excitation current  $i$ . From Fig. 1 (b), the phase voltage can be expressed by

$$V(t) = R \cdot i(t) + \frac{d\lambda(i, \theta)}{dt} \quad (1)$$

With

$$\lambda(i, \theta) = L(i, \theta) i \quad (2)$$

where  $\lambda$  is the flux linkage, which is dependent on  $i$  and  $\theta$ .  $v(t)$ ,  $i(t)$ , and  $L(i, \theta)$  are the instantaneous voltage across the excited phase winding, the excitation current, and the self-inductance, respectively. According to (1) and (2), the dynamic behavior of the  $m$ -phase SRM can be denoted as

$$V_k = \sum_{j=1}^m \left\{ (R_k + \omega \frac{\partial L_{kj}}{\partial \theta}) i_j + (L_{kj} + i_j \frac{\partial L_{kj}}{\partial i_j}) \frac{\partial i_j}{\partial t} \right\} \quad (3)$$

$k = 1, 2, \dots, m$

where  $\omega$  is the rotor angular velocity and  $m$  is the phase number. The obtained coenergy is equal to the area enclosed by the  $\lambda$ - $i$  curve over one excitation cycle and can be calculated by

$$W_{ce}(i, \theta) = \int_0^i \lambda(i, \theta) di \Big|_{\theta = \text{constant}} \quad (4)$$

For a specified current, the induced electromagnetic torque can be obtained by differentiating the coenergy  $W_{ce}$  with respect to the rotor position  $\theta$ , which can be expressed as

$$T_e(i, \theta) = \frac{\partial W_{ce}(i, \theta)}{\partial \theta} \Big|_{i = \text{constant}} \quad (5)$$

Here, we define an incomplete torque function as

$$T_k = \frac{1}{2} \sum_{j=1}^m \{ \text{sgn}(k, j) i_j \frac{\partial L_{kj}}{\partial \theta} \} \quad (6)$$

$k = 1, 2, \dots, m$

where

$$\text{sgn}(k, j) = \begin{cases} 1, & \text{if } k = j \\ -1, & \text{if } k \neq j \end{cases} \quad (7)$$

From (2) and (4)–(7), including the mutual inductance, the produced totally electromagnetic torque can be denoted as

$$T_e = \sum_{k=1}^m i_k T_k \quad (8)$$

The mechanical torque of the rotor can be expressed as

$$T_{mec} = T_e - B\omega - J \frac{d\omega}{dt} \quad (9)$$

where  $J$ ,  $B$ , and  $T_{mec}$  stand for the machine's moment inertia, friction coefficient, and mechanical torque, respectively.

### B. Drive System Architecture

Shown in Fig. 2 is the configuration of the studied SRM drive system. It consists of four controllers, which include the fuzzy speed controller, the PI current controller, the exciting angle regulation controller, and the commutation logic controller; a gate driver circuit with photo couplers; a power inverter; and the four-phase 6/8-pole SRM. The fuzzy speed controller receives the speed error signal and converts it into four-phase current commands that will be sent to the current controller. The actual current, sensed by the Hall-effect sensor, is compared with the current command to obtain the current error. According to the error value, the pulse width modulation gating signals of insulated-gate bipolar transistors in an asymmetric half-bridge power inverter are generated by the current controller. The gating signals drive the power inverter through the photo coupler isolation. Z-source inverter system for adjustable speed drives (ASD) it can produce any desired output ac voltage, even greater than the line voltage. It reduces line harmonics, and extends output voltage range. ZSI exhibits both voltage-buck and voltage-boost capability. With the inputs of actual speed, speed errors, current, and rotor position, both algorithms of torque iterative learning control (TILC) and energy iterative learning control (EILC) are run to minimize the torque ripple and energy conversion loss by regulating the incremental turn-on and turn-off angles ( $\Delta\theta_{on}$ ,  $\Delta\theta_{off}$ ) and the duty cycle ( $D$ ) to enhance the driving performance. The commutation logic controller is used to derive and determine the phase commutation moment according to the rotor position, excitation turn-on angle, and turn-off angle. In order to simplify the hardware complexity, all of the four controllers are implemented on a DSP-based DSPACE control platform.

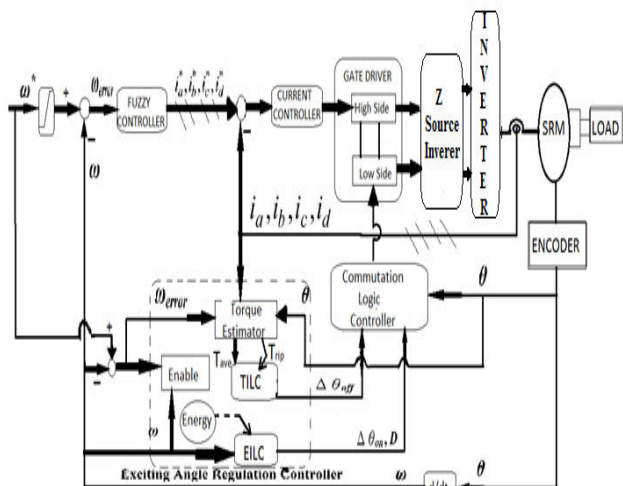

Fig. 2 Architecture of the SRM drive system

### III. FUZZY LOGIC CONTROLLER DESIGN

In this section, the fuzzy control fundamentals will be outlined first, and then, the key point of self-tuning PI-like fuzzy controller (STFC) will be briefly reviewed. Afterward, the modified design of the proposed STFC will be described in detail.

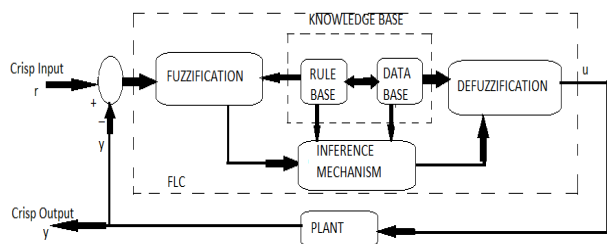

Fig. 3 Basic structure of a fuzzy logic control system

#### A. Fuzzy Control Philosophy

A basic FLC system structure, which consists of the knowledge base, the inference mechanism, the fuzzification interface, and the defuzzification interface, is shown in Fig. 3. Essentially, the fuzzy controller can be viewed as an artificial decision maker that operates in a closed-loop system in real time. It grabs plant output  $y(t)$ , compares it to the desired input  $r(t)$ , and then decides what the plant input (or controller output)  $u(t)$  should be to assure the requested performance. The inputs and outputs are “crisp.” The fuzzification block converts the crisp inputs to fuzzy sets, and the defuzzification block returns these fuzzy conclusions back into the crisp outputs. Inference engine using if-then type fuzzy rules converts the fuzzy input to the fuzzy output.

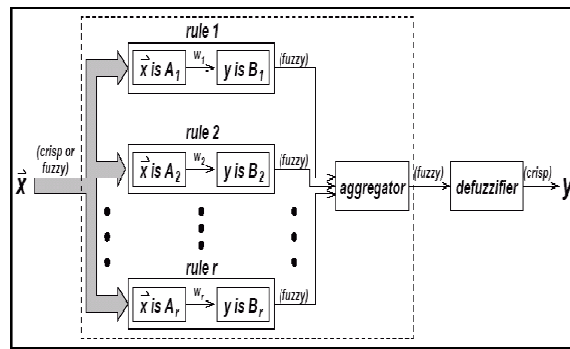

Fig. 4 Basic structure of an Inference engine

#### B. Overview of Self-Tuning FLC

The PI-like fuzzy controller (PIFC) is driven by a set of control rules rather than constant proportional and integral gains. The block diagram of an STFC is shown in Fig. 5. Adaptability is necessary for fuzzy controllers to ensure acceptable control performance over a wide range of load variations of inaccurate operating knowledge or plant dynamic behavior. These are the commonly used methods to make a fuzzy controller adaptive: input or output SF tuning, MF definition and control rule modification. In a classical fuzzy controller, the UOD tuning of the MFs of the input or output variables can be used to overcome the steady-state error. Here, a discrete-time controller with two inputs and a single output is considered. From Fig. 6, the error  $e$  and change of error  $\Delta e$  are used as the input variables, which are defined as,

$$e(k) = r(k) - y(k) \quad (10)$$

$$\Delta e(k) = e(k) - e(k-1) = y(k-1) - y(k)$$

$$\text{if } r(k) = r(k-1) \quad (11)$$

where  $r$  and  $y$  denote the reference command and plant output, respectively. Indices  $k$  and  $k-1$  represent the current and previous states of the system, respectively. The controller output is the incremental change of the control signal  $\Delta u(k)$ . The control signal can be obtained by

$$u(k) = u(k-1) + \Delta u(k) \quad (12)$$

The UOD in all membership functions of the controller inputs, i.e.,  $e$  and  $\Delta e$ , and output, i.e.,  $\Delta u$ , are defined on the normalized domain with the gain updating factor  $\alpha$  of  $7 \times 7$  rule base (which is utilized to fine tune the output SF) over the interval  $[-1, 1]$ , as shown in Fig. 6. The linguistic values NB, NM, NS, ZE, PS, PM and PB stand for negative big, negative medium, negative small, zero, positive small, positive medium and positive big, respectively.

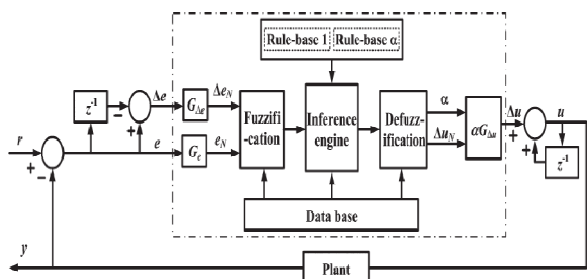

Fig. 5 Block diagram of an STFC

TABLE I  
 RULE BASE (7X7) FOR DERIVING OUTPUT VARIABLE ΔU

$\begin{matrix} e \\ \Delta e \end{matrix}$	NB	NM	NS	ZE	PS	PM	PB
NB	NB	NB	NB	NM	NS	NS	ZE
NM	NB	NM	NM	NM	NS	ZE	PS
NS	NB	NM	NS	NS	ZE	PS	PM
ZE	NB	NM	NS	ZE	PS	PM	PB
PS	NM	NS	ZE	PS	PS	PM	PB
PM	NS	ZE	PS	PM	PM	PM	PB
PB	ZE	PS	PS	PM	PB	PB	PB

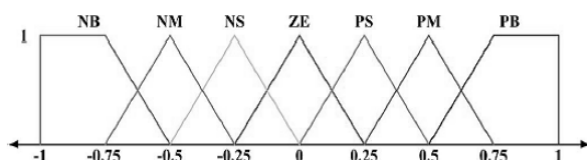

Fig. 6 Membership functions of  $e$ ,  $\Delta e$ , and  $\Delta u$  with gain updating factor  $\alpha$  of 7x7 rule base

The actual output of the self tuning FLC is obtained by using the effective SF  $\alpha G\Delta u$ . Hence, adjusting the SFs can modify the corresponding UODs of the control variables. As shown in Fig.5, the relationships between the SFs and the input and output variables of the STFC can be expressed as follows:

$$e_N = G_e e \quad (13)$$

$$\Delta e_N = G_d \Delta e \quad (14)$$

$$\Delta u = (\alpha G \Delta u) \Delta u_N \quad (15)$$

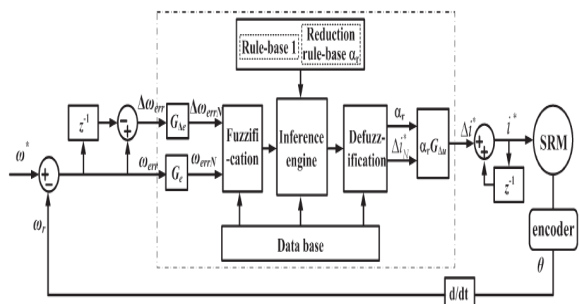

Fig. 7 Block diagram of the proposed FLC with a simplified reduction of the control rule

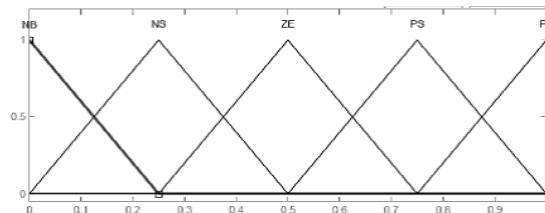

Fig. 8 Membership functions of  $e$ ,  $\Delta e$ , and  $\Delta u$  with gain updating factor  $\alpha$  of 5x5 rule base

TABLE II  
 RULE BASE (5X5) FOR DERIVING OUTPUT VARIABLE ΔU

	$\Delta e$	NB	NS	ZE	PS	PB
$e$	o/p					
NB	NB	NB	NS	NS	NS	ZE
NS	NB	NS	NS	NS	ZE	PS
ZE	NS	NS	ZE	PS	PS	PS
PS	NS	ZE	PS	PS	PS	PB
PB	ZE	PS	PS	PB	PB	PB

The UOD in all membership functions of the controller inputs, i.e.,  $e$  and  $\Delta e$ , and output, i.e.,  $\Delta u$ , are defined on the normalized domain with the gain updating factor  $\alpha$  of 5x5 rule base (which is utilized to fine tune the output SF) over the interval [0,1], as shown in Fig. 8. The linguistic values NB, NS, ZE, PS, and PB stand for negative big, negative small, zero, positive small, and positive big, respectively.

### C. Self-Tuning FLC with Control Rule Reduction

This work presents a simple but robust model-independent self-tuning mechanism for FLCs with the most important feature that it depends neither on the process being controlled nor on the controller used. The control algorithm must be implemented on the microcontroller with limited memory space and computational capability. The rule base of the STFC proposed in choose five fuzzy sets for each membership function of the input variables  $e$  and  $\Delta e$ . Twenty-five fuzzy rules are needed for deriving controller output  $\Delta u$  and  $\alpha$ , respectively. This paper focuses on, first, the reduction of the number of fuzzy rules for deriving  $\alpha$  and, second, the simplification of the memory requirement and computational complexity of the designed controller.

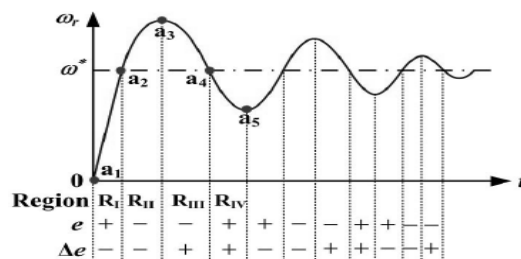

Fig. 9 Dynamic behavior of motor step response of 7x7 rule base

The dynamic behavior of motor step response of 7x7 rule base as shown in fig 9. The speed response can be roughly divided into four regions, i.e., RI–RIV, and two sets of particular points, i.e., crossover points ( $a_2$ ,  $a_4$ ) and peak points

(a3, a5). According to the definitions of (10) and (11), the signs of  $e$  and  $\Delta e$  will change when the response curve passes through the different regions.

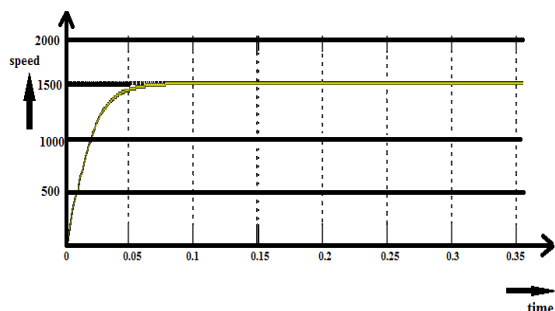

Fig. 10 Dynamic behavior of motor step response of the simplified rule base derivation

But here, the focus is on the reduction of rule numbers for deriving updating factor  $\alpha$ . In the proposed scheme, to reduce the rule numbers, a practical observation of the motor step response, as shown in Fig 10. The proposed frame of the reduced rule base for deriving  $\alpha$  is shown in Table I. In this proposed scheme, although there are 25 control rules. Each time, only five control rules are used to derive  $\alpha$  when the chosen subroutine is executed. Therefore the dynamic behavior of motor step response of control rule reduction will attain its steady state very quickly by using (5x5=25) rules. This may result in short settling time and there is very small oscillation around the preset speed when the system approaches the steady state.

#### D. Gain Tuning Strategy

The PIFC without scaling gain tuning mechanism has a drawback, the defined domain of the input and output variables are fixed. This may result in long settling time and oscillation around the preset speed when the system approaches the steady state. In order to obtain satisfactory performance, the UOD of the controller should be adjusted according to the operating point. Therefore, the fuzzy controller, which can change UOD by tuning scaling gains through a continuous and nonlinear variation of the updating factor, is developed. Here, the attention is focused on the tuning of output scaling gain because it is equivalent to the controller gain. The self-adjusting mechanism of the proposed fuzzy controllers is described as follows:

1. Variation Effect of Input and Output SFs: SF modulation is one of the most employed solutions to enhance the performance of a fuzzy controller. The design of the SFs, particularly the output SF, is very crucial in an FLC because of their influences on the performance. The effect of SF adjustment is equivalent to extending or shrinking the actual UOD of the input and output variables.
2. Self-Tuning Mechanism: The systemic methods for gain tuning to obtain the optimal response because the determination of the optimal values of the adjustable parameters requires the knowledge of a precise model of the plant. The design guidelines are described as follows:

Step 1. Set  $\alpha$  or  $\alpha_i$  as 1.0 (without gain tuning), and obtain the most suitable values of  $G_e$ ,  $G\Delta e$ , and  $G\Delta u$  using the simple method. For the proposed two FLCs, the proper initial values of  $G_e$ ,  $G\Delta e$ , and  $G\Delta u$  can be obtained by (16) for control rule reduction. Choosing  $G_e$ ,  $G\Delta e$  and  $G\Delta u$  to cover the whole normalized domain  $[-1, 1]$  or interval  $[e_{min}, e_{max}]$ . An appropriate initial operating condition is obtained when a good transient response is achieved.

$$G_e = \frac{1}{\omega_{err,max}} \text{ (or } \frac{1}{|\omega_{err,min}|} \text{)}$$

$$G\Delta e = \frac{1}{\Delta\omega_{err,max}} \quad G\Delta u = \Delta u_{max} \quad (16)$$

Step 2. In this step, the controller output and updating factor can be expressed by (17) and (18), respectively,  $f_{\alpha}$  index is a nonlinear function and  $k\Delta u$  is the scaling constant of  $G\Delta u$ . Here,  $G\Delta u$  is set  $k\Delta u$  times greater than that obtained in Step1. The determination of  $k\Delta u$  is empirical. For example, if the system is required to keep tracking the command without any overshoot,  $k\Delta u$  can be set small to get a smaller output. At the same time, the output SF can be fine-tuned by altering the value of  $\alpha_{index}$  to achieve a relatively small but satisfactory output and guarantee a faster response with relatively small overshoot.

$$\Delta u(k) = \alpha_{index}(k) (k\Delta u G\Delta u) \Delta u_N \quad (17)$$

$$\alpha_{index}(k) = f_{\alpha index}(e(k), \Delta e(k)) \quad (18)$$

Finally, the performance comparison to shows that the STFC with the simplified rule base is the best among the existing methods and also demonstrates that the proposed controller can quickly regulate itself to adapt to the current environmental change.

#### IV. CONCLUSION

In this paper, based on an improved performance of the closed loop control of Switched Reluctance Motor drives using Z-Source Inverter with the simplified rule base of Fuzzy Logic Controller (FLC) with the output scaling factor (SF) self-tuning mechanism by altering a gain updating factor has been devised. The modified rule bases are designed to simplify the program complexity of the controller by reducing the number of fuzzy sets of the membership functions without losing the system performance and stability using the adjustable controller gain. Z-source inverter, that exhibits both voltage-buck and voltage-boost capability. It reduces line harmonics, improves reliability, and extends output voltage range. The proposed controller can also simplify the complexity of the control system. Based on the dSPACE DS1104 platform, tests on a four-phase 6/8- pole SRM under the speed set-point change and load disturbance have been carried out to measure various performance indices such as peak overshoot or undershoot, steady-state error, rise time, settling time, etc.

Then the results of the proposed control, shows very good stability and robustness against speed and load variations over a wide range of operating conditions and also the performance of the proposed controllers will be compared with conventional counterpart.

#### REFERENCES

- [1] P. C. Desai, M. Krishnamurthy, N. Schofield, and A. Emadi, "Novel switched reluctance machine configuration with higher number of rotor poles than stator poles: Concept to implementation," *IEEE Trans. Ind. Electron.*, vol. 57, no. 2, pp. 649–659, Feb. 2010.
- [2] J. Corda and S. M. Jamil, "Experimental determination of equivalent circuit parameters of a tubular switched reluctance machine with solid-steel magnetic core," *IEEE Trans. Ind. Electron.*, vol. 57, no. 1, pp. 304–310, Jan. 2010.
- [3] P. Vas, "Artificial-Intelligence-Based Electrical Machines and Drives: Application of Fuzzy, Neural, Fuzzy-Neural, and Genetic-Algorithm-Based Techniques," London, U.K.: Oxford Univ. Press, 1999.
- [4] S. Mir, M. E. Elbuluk, and I. Husain, "Torque-ripple minimization in switched reluctance motors using adaptive fuzzy control," *IEEE Trans. Ind. Appl.*, vol. 35, no. 2, pp. 461–468, Mar./Apr. 1999.
- [5] A. G. Perry, G. Feng, Y. F. Liu, and P. C. Sen, "A design method for PI-like fuzzy logic controller for DC–DC converter," *IEEE Trans. Ind. Electron.*, vol. 54, no. 1, pp. 190–199, Feb. 2007.
- [6] S. Chowdhuri, S. K. Biswas, and A. Mukherjee, "Performance studies of fuzzy logic based PI-like controller designed for speed control of switched reluctance motor," in *Proc. IEEE Int. Conf. Ind. Electron. Appl.*, 2006, pp. 1–5.
- [7] J. Xiu and C. Xia, "An application of adaptive fuzzy logic controller for switched reluctance motor drive," in *Proc. IEEE Fuzzy Syst. Knowl. Disc.*, 2007, pp. 154–158.
- [8] T. Koblara, "Implementation of speed controller for switched reluctance motor drive using fuzzy logic," in *Proc. OPTIM*, 2008, pp. 101–105.
- [9] Santosh sonar and Tanmoy maity, "Z-source Inverter based control of Wind Power," presented at the *IEEE Industry Applications Soc. Annu. Meeting*, 2011.
- [10] Fang Zheng Peng, Alan Joseph, JinWang, Miaosen Shen, Lihua Chen, Zhiguo Pan, Eduardo Ortiz-Rivera, and Yi Huang, "Z-Source Inverter for Motor Drives," *IEEE Trans. Power Electron.*, vol. 20, no. 4, pp. 857–863, July 2005.
- [11] M. Balamurugan, T.S. Sivakumaran, and M.Aishwariya Devi, "Voltage Sag/Swell Compensation Using Z-source Inverter DVR based on FUZZY Controller," presented at *IEEE International Conference on Emerging Trends in Computing, Communication and Nanotechnology*, pp. 648–653, 2013.

**HariPrabhu** received his B.E Degree in Electrical & Electronics Engineering from Thiagarajar College of Engineering, Madurai, TamilNadu, India in 2012. Currently he is pursuing M.E in Power Electronics and Drives affiliated to Anna University-Chennai, TamilNadu, and likely to complete in July 2014. His research interests in Switched Reluctance Motor Drives and power Electronics.