

# Control Signal from EOG Analysis and Its Application

Myoung Ro Kim, Gilwon Yoon

**Abstract**—A game using electro-oculography (EOG) as control signal was introduced in this study. Various EOG signals are generated by eye movements. Even though EOG is a quite complex type of signal, distinct and separable EOG signals could be classified from horizontal and vertical, left and right eye movements. Proper signal processing was incorporated since EOG signal has very small amplitude in the order of micro volts and contains noises influenced by external conditions. Locations of the electrodes were set to be above and below as well as left and right positions of the eyes. Four control signals of up, down, left and right were generated. A microcontroller processed signals in order to simulate a DDR game. A LCD display showed arrows falling down with four different head directions. This game may be used as eye exercise for visual concentration and acuity. Our proposed EOG control signal can be utilized in many other applications of human machine interfaces such as wheelchair, computer keyboard and home automation.

**Keywords**—DDR game, EOG, eye movement.

## I. INTRODUCTION

**E**OG (Electro-OculoGraphy) is the electric potential of the retinal in the human eye. Electric potentials appear everywhere muscular activities are involved. The muscular activities activate or deactivate ions whose propagation generates currents. Electrodes can detect ion currents or electro-potential conveniently. Strong signals among electric potentials are ECG (Electro-CardioGraphy), EMG (Electro-MyoGraphy) and EOG.

EOG signal is generated by the potential difference between cornea and retina. Different eye movements produce various EOG wave patterns. Often pairs of the electrodes are placed around the eye. Typically EOG amplitudes range between 0.05 and 3 mV and a frequency band from DC to 50 Hz. EOG signal has an advantages of linearity and wide potential range. It belongs to one of easily measurable biopotentials along with ECG and EMG. Activities of muscle and eyelids influence EOG. Therefore, disadvantages are the influences of muscles and eyelid twitching and accuracies may be lowered due to these other conditions.

There have been various investigations on the uses of EOG. One of the most popular applications is human machine interface (HMI) for controlling devices such as computer, wheelchair and mouse [1]-[6]. Other applications include activity recognition, drowsiness detection and gaze estimation [7]-[9]. In case of lack in muscular actions of an individual,

M. R. Kim is with the Department of Electronic & IT Media Engineering, Seoul National University of Science and Technology, Seoul, Korea (e-mail: mrkim@seoultech.ac.kr).

G. Yoon is with the Department of Electronic & IT Media Engineering, Seoul National University of Science and Technology, Seoul, Korea (Corresponding author; phone: 82-2-970-6419; fax: 82-2-979-7903; e-mail: gyoony@seoultech.ac.kr).

EOG can be a good candidate for HMI applications.

In this study, a new application of EOG was introduced. The rapid development of information technology has made a heavy involvement of computer, smartphone and other electronic devices with displays. People are exposed to abuse of eyes and amblyopia. It is common belief that the eyeball exercise can be beneficial to the health of eyes. It has been reported that the exercise of eye movement can increase concentration and improve visual acuity [10]. There can be various ways for eye exercises. People can be easily involved with an eye exercise whose practice is of fun. For this purpose, a DDR (dance dance revolution) game device was introduced where EOG control signals produced from eye movement [11]. The device consisted of EOG detection circuit, a microcontroller and LCD display.

There has been a study where the classification of 16 different EOG signals was made in real time use [12]. Gaze on the screen and the identification of a point on the screen is another application where multiple signal classifications are required [13]. However, reliable and non-ambiguous signal identification for a particular eye movement can be rather difficult to be achieved in real situation since EOG signals are complex in nature. In this study, only several eye movements that can be clearly distinguished were selected in order to implement them in a game algorithm using EOG.

## II. METHODS

Fig. 1 shows the diagrams of EOG amplitude and phase with respect to the direction of eyeball movement. The cornea side is designated as positive whereas the retina side is negative. This illustrates potential difference. One electrode is attached to the positive input of a comparator and the other one is the negative input. No potential difference is measured when eyeballs are aligned to the center (top in Fig. 1). Eyeballs rotate to the right and a positive pulse is detected (middle in Fig. 1). In the same manner, a negative pulse is measured when the eyeballs move to the left.

Fig. 2 shows the block diagram of measuring EOG signal. Disposable Ag/AgCl electrodes were used for EOG measurement and one set consisted of three electrodes. One was connected to the positive input, another to the negative input and the last one as reference of the instrumentation amplifier (IA) as shown in Fig. 1. Differential amplification by IA removed common signal with very high input impedance and raw EOG signal was detected. A system would be bulky if AC power supply has to be used. Therefore batteries were used and DC 9 and -9 volts were set to be power voltages.

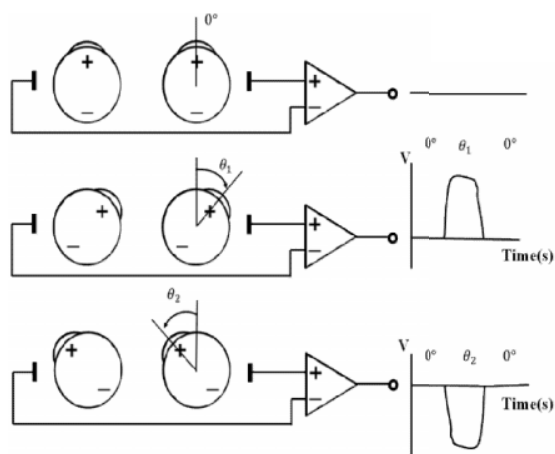

Fig. 1 Output signal of comparator; no signal when eyeball are centered (top), positive pulse with movement to the right (middle) and negative pulse with movement to the left (bottom)

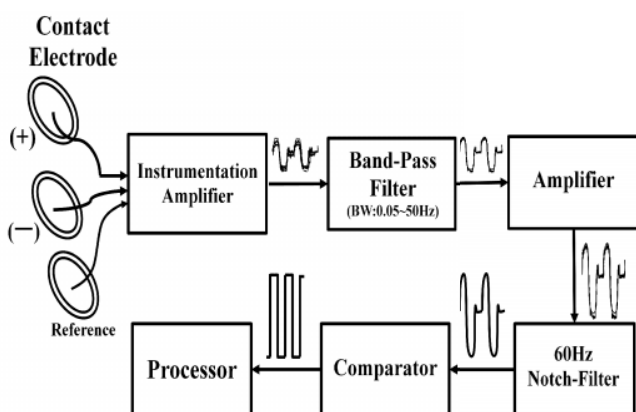

Fig. 2 Measurement circuit of EOG signal

In order to remove DC and high frequency, bandpass filtering with 0.05 and 50 Hz cutoffs was applied. IA had also amplification factor. Once again additional signal amplification was made. Signal was amplified at few separate stages so that wider bandwidth could be achieved. 60 Hz noise is the power source noise and exists ubiquitously. Therefore, 60 Hz notch filtering was added. In our case, 'on' and 'off' control signal was sufficient. To avoid faulty operations, enough amplification was made to saturate or cutoff the signal. A comparator was used to shape waveform to be suitable as digital input to the microprocessor.

Locations of the attached electrodes are shown in Fig. 3 where vertical and horizontal channels are assigned. The reference electrode was attached between the eyes and functioned as common for both vertical and horizontal channels. In this manner, eye movements to the right and to the left produce opposite polarities and differentiating control signals become clearer. A pair of electrodes are attached on the above and on the below of one eye as shown in Fig. 3. This pair produced on and off signals when eye moves up and down.

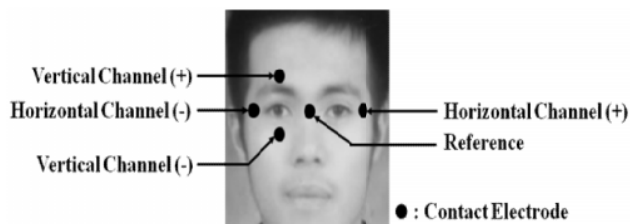

Fig. 3 Attachment of the electrodes around the eyes

A pair of electrodes was located at the equal distance from the reference electrode when one looks forwardly. This will produce zero voltage at the detector as shown in Fig. 1. Measured voltage became positive when eyeballs moved to the right horizontally since cornea was closer to the positive input. With eyeballs to the left, measured voltage became negative because cornea moved towards the negative input. In the same manner, vertical movement of eyes upward or downward produced signal with the opposite phase.

It was necessary to process digital signal to be suited for the input-output interface of the microprocessor. Measured EOG signal reaches to +9 V when subjects look upward and -9 V downward. Signals were fully saturated with high amplification. Two different threshold levels were assigned to detect up and down movements. One threshold level was not sufficient to detect the signal reliably due to drift of DC level, noises and erratic eye movements such as flickering. In this manner, no unintended control signal was generated except up or down eyeball movement. The same process was applied for the horizontal channel. Digital signals were converted to analogue signals. The microprocessor adapted the interrupt method where a control signal was identified as interruption for the microprocessor.

### III. EXPERIMENT & RESULTS

As shown in Figs. 2 and 3, a set of three electrodes measures EOG signal. The same reference between the eyes shared for horizontal and vertical channels. Therefore, a total of five electrodes were used. The horizontal channel identified left and right movements. The vertical channel differentiated up and down movements. In this manner, four different control signals according to eye movements were generated. One control signal was available one at a time and that corresponded to one of the four directions of DDR arrows.

Both horizontal and vertical EOG signals were utilized. For the horizontal channel, the reference electrode was located between the measurement electrodes. As results, left and right eye movements produced positive and negative pulses which were symmetric with respect to baseline. If a reference electrode was not attached to be at the equal distance from two measurement electrodes EOG signals were not symmetric with respect to the base baseline. Pulse with larger amplitude would produce when one electrode was located closer to the other one. It made reliable identification to be more difficult. This problem was solved by sharing the reference point between eyes since this made the distance from two electrode of the vertical channel to be equal.

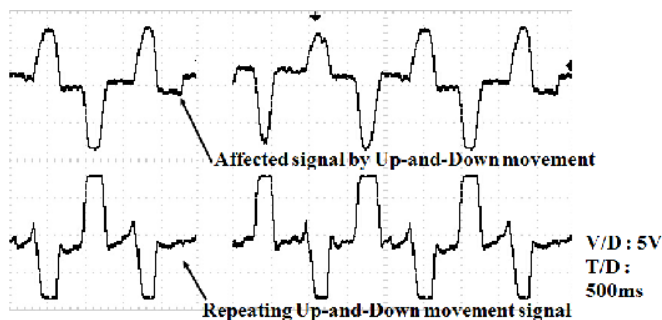

Fig. 4 EOG waveform during repeated up and down eye movements; horizontal channel (up) and vertical channel (bottom)

Another complication was influences between two channels. It is not possible to have signal from only one channel since complex muscle structures of the eye. An example is shown in Fig. 4 where repeated up and down movements were exercised. Upper figure shows waveform of the horizontal channel and lower figure for the vertical channel. During up and down movements, clear pulses were shown in the lower waveform. However, there were also horizontal signals. These were not apparently what we expected and were not also negligible in terms of amplitudes. Vice versa, there were signals in the vertical channel (affected signal, bottom waveform in Fig. 5) during left and right eye movements. Even though the amplitude was smaller and phase relationship was distorted. These channel interferences can cause mistakes.

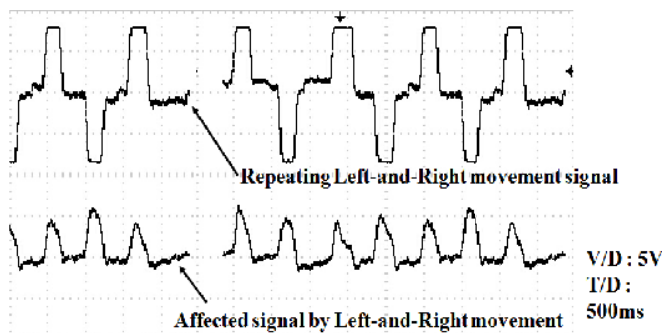

Fig. 5 EOG waveform during repeated left and right eye movements; horizontal channel (up) and vertical channel (bottom)

In order to deal with the interference effects and to identify four control signals of up, down, left and right, the microprocessor recorded all four signals and processed them. First, threshold levels should be sufficiently high to remove were influenced or affected among them. Therefore, all four wave patterns should be compared.

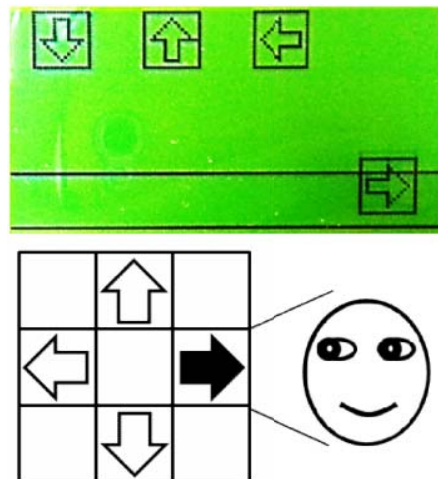

Fig. 6 DDR game using EOG signals; measured EOG of left, right, up and down selects corresponding the arrow directions. A LCD monitor displays falling arrows. Scores are gained when the EOG arrow and that of arrow on display match

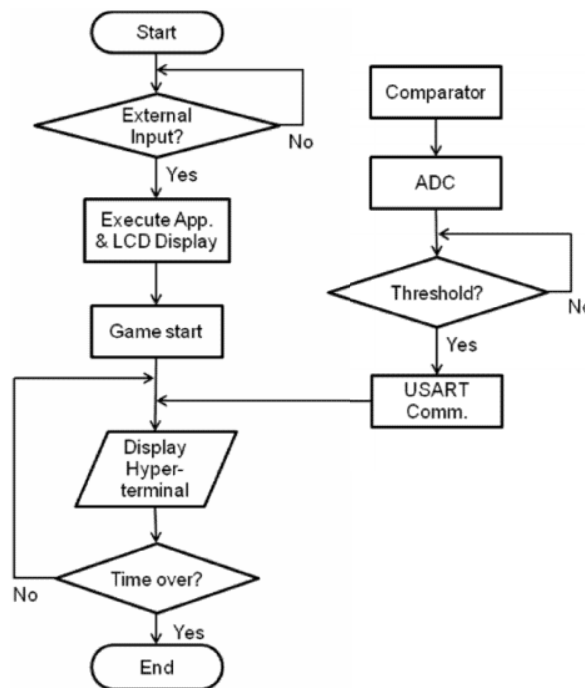

Fig. 7 Flowchart of a DDR game that uses EOG control signals as the arrows of up, down, left and right direction

Dance Dance Revolution (DDR) is a rhythm dance game. One dances according to the arrow directions that fall down on the computer screen. Often one dances in accordance with footsteps. However, various matching techniques to the arrows can be available using other parts of body such as fingers. In this study, it was arranged that four EOG signals corresponded to footsteps. It means that eye movements according to arrow directions were used to do DDR game as shown in Fig. 6.

Fig. 7 show a flowchart of DDR game illustrated in Fig. 6. In this study, a game device consisted of electronic circuits, display and the hyper-terminal of laptop computer. The

electronic circuit described in Fig. 2 measured EOG and housed the microprocessor. The LCD display was showing the arrows and the hyper-terminal of laptop worked as database of game. LCD monitor becomes on and ready for the game when the execution program is on. When proper EOG signals are detected, the hyper-terminal display functions related EOG DDR game.

DC levels became difficult to go back to zero level when the same direction of EOG signals was commanded repeatedly. Signal pulse happened to appear before DC level reaches to zero voltage. Threshold levels were important to guarantee reliable detections. For this purpose, signal was amplified sufficiently and threshold levels were set to be above noises or erratic signals.

#### IV. DISCUSSIONS

Clear and distinctive EOG signals could be produced when only four classifications were necessary. It appeared that clear distinctions among EOG signals were difficult to obtain with more than four classifications. This is rather apparent since muscles associated eye movements are complicated and have almost infinite number of freedom degrees. It was necessary for a subject to control his or her eye movements with definite attention. This would be of course to be good exercises for eyes. That was why EOG control signals were applied for the DDR rhythmic dance game.

For commercial uses, the game can be made to be compact and light if a portable electrode headset with five contact points is provided. However, further investigation should be followed for the increase of response time. This implies faster game speed. At the same time, it indicates that more reliable classification techniques should be implemented. For this purpose, other distinct EOG signals such as saccades, fixations and blinks can be added. These three types of EOG show different EOG wave patterns than those produced by eye movements of four directions [14]. Therefore, additional commands such as start, reset or end can be added.

Our study can be applied not only for the DDR game but also for other diverse applications of human machine interface. For more elaborate controls, other biosignals may be included. EMG is a good candidate. EMG can be very effective if particular muscle movements are involved for specific actions in HMI. Another candidate is EEG since integration of EEG and EOG can provide with synergetic effect. This implies that more control signals can be available.

#### ACKNOWLEDGMENT

This study was supported by Seoul National University of Science and Technology.

#### REFERENCES

- [1] E. Ianez, A. Ubeda, and J. M. Azorin, "Multimodal human-machine interface based on a brain-computer interface and an electrooculography interface", in *Proc. Engineering in Medicine and Biology Society, 2011 Annual International Conference of the IEEE*, pp. 4572-4575.
- [2] Chung-Hsien Kuo, Yi-Chang Chan, Hung-Chyun Chou, and Jia-Wun Siao, "Eyeglasses Based Electrooculography Human-wheelchair

- Interface", in *Proc. Int. Conf. Systems, Man and Cybernetics, 2009*, Man and Cybernetics, San Antonio, Tx, pp. 4746-4751.
- [3] H. Tamura, M. Miyashita, K. Tanno, Y. Fuse, "Mouse cursor control system using electrooculogram signals", in *2010 Proc. World Automation Congress*, pp.1-6.
- [4] Rafael Barea, Luciano Boquete, Manuel Mazo, Elena Lopez, "System for Assisted Mobility Using Eye Movements Based on Electrooculography", *IEEE Trans on Neural Systems and Rehabilitation Engineering*, vol. 10, no. 4, pp. 209-218, Dec 2002.
- [5] Su Jong Kim, Ho Sun Ryu, Young Chol Kim, "Development of Interface device with EOG Signal", *The Korean Institute of Electrical Engineers, 37th Proceedings of the Korean Institute of Electrical Engineers*, 2006.7, pp 1821-1823.
- [6] Yonugmin Kim, Nakju Doh, Youngil Youm, and Wan Kyun Chung, "Development of Human-mobile Communication System using Electrooculogram Signals", in *Proc. IEEE/RSJ International Conference on Intelligent Robotics and Systems*, Maui, Hawaii, USA, 2001, pp 2160-2165.
- [7] A. Bulling, J. A. Ward, H. Gellersen, and G. Troster, "Eye Movement Analysis for Activity Recognition Using Electrooculography", *IEEE Trans on Pattern Analysis and Machine Intelligence*, vol. 33, no. 4, pp. 741-753, April 2011.
- [8] T.C. Chieh, M. M. Marzuki, H. Aini, H. S. Farshad, M. B. Yeop, "Development of vehicle driver drowsiness detection system using electrooculogram (EOG)", in *Proc. Int. Conf. Computer, Communications, & Signal Processing with Special Track on Biomedical Engineering 2005*, pp. 165-168.
- [9] Mingmin Yan, Hiroki Tamura, Koichi Tanno, "Gaze Estimation using Electrooculogram Signals and its Mathematical Modeling", in *Proc. IEEE 43rd International Symposium on Multiple-Valued Logic (ISMVL) 2013*, pp. 18-22.
- [10] Park Gee-Ho, Choi Byung-Jin, Joo Dong-Hwan, "The Change of Visual Acuity through Eye Exercise for Elementary School Children", *INHA UNIV. Sports Science Institute, Journal of Sports Sciences* 14, 2002.12, pp 63-75.
- [11] [http://en.wikipedia.org/wiki/Dance\\_Dance\\_Revolution](http://en.wikipedia.org/wiki/Dance_Dance_Revolution)
- [12] M Trikha, A Bhandari, T Gandhi, "Automatic Electrooculogram Classification for Microcontroller Based Interface Design", in *Proc. IEEE Systems and Information Engineering Design Symposium (SIEDS) 2007*, pp. 1 - 6.
- [13] D. H. Lee, J. H. Yu, D. H. Kim, "Extraction of gaze point on screen using EOG signal", *Rehabilitation Engineering and Assistive Technology Society of Korea, Proceedings of RESKO*, 11. 2011, pp 62-64.
- [14] A. Bulling, J. A. Ward, H. Gellersen and G. Troster, "Eye Movement Analysis for Activity Recognition using Electrooculography", *IEEE Trans on Pattern Analysis and Machine Intelligence*, vol. 33, no. 4, pp. 741-753, April 2011.

**Myoung-Ro Kim** was born in Pohang, South Korea (1989). He is a student at the Department of Electronic & IT Media Engineering, Seoul National University of Science and Technology. He engages in biosignal measurement and instrumentation.

**Gilwon Yoon** received his B.S. in Electrical Engineering from Seoul National University, Seoul, Korea in 1977. His degrees of M.S. and Ph.D. in Electrical and Computer Engineering were obtained from the University of Texas at Austin, U.S.A. in 1982 and 1988 respectively. He worked as Medical Team Director at Samsung Advanced Institute of Technology, Korea between 1992 and 2003. He is currently professor at Seoul National University of Science and Technology since 2003.