

Technique for Voltage Control in Distribution System

S. Thongkeaw, M. Boonthienthong

Abstract—This paper presents the techniques for voltage control in distribution system. It is integrated in the distribution management system. Voltage is an important parameter for the control of electrical power systems. The distribution network operators have the responsibility to regulate the voltage supplied to consumer within statutory limits. Traditionally, the On-Load Tap Changer (OLTC) transformer equipped with automatic voltage control (AVC) relays is the most popular and effective voltage control device. A static synchronous compensator (STATCOM) may be equipped with several controllers to perform multiple control functions. Static Var Compensation (SVC) is regulation slopes and available margins for var dispatch. The voltage control in distribution networks is established as a centralized analytical function in this paper.

Keyword—Voltage Control, Reactive Power, Distribution System.

I. INTRODUCTION

VOLTAGE is one of the most important parameters for the control of electric power systems. The On-Load Tap Changer (OLTC) transformers are used between these multiple voltage levels to regulate and maintain the voltage which is supplied to consumers within statutory limits. The OLTC voltage regulation is naturally operated by changing the number of turns in one winding of the transformer to physically alter the ratios of the transformer. The On-Load Tap Changer (OLTC) transformers are used between these multiple voltage levels to regulate and maintain the voltage which is supplied to consumers within statutory limits. The OLTC voltage regulation is naturally operated by changing the number of turns in one winding of the transformer to physically alter the ratios of the transformer [1].

The objective of the proposed approach is not to control bus voltage but to guarantee that generator injections alone do not cause significant voltage rise a solution in which distribution network operators (DNOs) are kept to their traditional task of voltage regulation for load demand. Most DNOs require distributed generation (DG) to operate at zero reactive power or at fixed power factor, limiting the amount of installed capacity to guarantee an admissible voltage profile in the worst case scenario. Reasons for the limitation are that DG single unit capacity is typically too small to control network voltage DG automatic voltage control can interfere with DNO control, namely, with the on-load tap-changing transformer operation, which may increase the risk of islanding [2].

Volt/Var control has received an ever-increasing attention from the electric utility industry in recent years due to concerns regarding limited transmission capabilities, system

loss, and system security. At this level, there are several major system components that can affect the control of voltage and reactive power. These components are the load tap changing transformers, the line voltage regulators, and the capacitor banks.

II. TECHNIQUE FOR VOLTAGE CONTROL

A. Automatic Voltage Control

The basic operation and the general arrangement of the OLTC and a simple automatic voltage control (AVC) relay with the comparison between load voltage and target voltage, the AVC relay determines whether to adjust the tap position or not in order to maintain the required voltage level. To deal with the voltage control problems together with the increasing penetration of the DGs as well as the use of Smart Grid, DNOs need more stable and effective OLTC voltage control schemes [3]. This simple equation (1) can be used to analyze qualitatively the relationship between the voltage at bus 2 and the amount of generation that can be connected to the distribution network, as well as the impact of alternative control actions which is shown in Fig. 1.

$$V_2 \approx V_1 + R(P_n - P_L) + (\pm Q_n - Q_L \pm Q_C)X \quad (1)$$

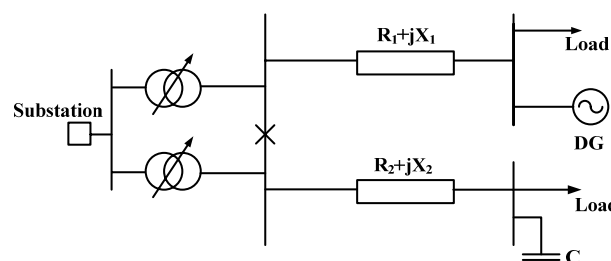

Fig. 1 Simple system for voltage control

Capacitor placement in distribution feeder is the well known efficient method for improving overall power delivery in an electric distribution system. With shunt capacitors, reactive power compensation is provided to reduce power and energy loss, to regulate bus voltages, to improve power quality, and to release feeders and system capacity [4].

B. Synchronous Condenser

Synchronous condenser has played a major voltage and reactive power control. They have been a both sub transmission and transmission voltage level improve stability and to maintain voltage with in desired limit under varying load condition and contingency situation. The control of voltage levels is accomplished by controlling the generation, absorption and flow of reactive power at all levels in the

S. Thongkeaw and M. Boonthienthong are with the Department of Electrical Engineering, Faculty of Engineering, Rajamangala University of Technology Phra Nakhon, Bangkok, Thailand (e-mail: somkieat.t@rmu.ac.th, manat.b@rmu.ac.th).

system. The generating units provide the basic means of voltage control. The automatic voltage regulators control field excitation to maintain a scheduled voltage level at the generators terminals. Additional means are usually required to control voltage throughout the system. The devices used for this purpose may be classified as follows [5]. The voltage control problem is often called the reactive power control problem since the terminal voltage of a synchronous generator is controlled by varying its reactive power output through the action of the excitation system [6].

C. Regulate Voltage

The On-Load Tap Changer (OLTC) transformer equipped with automatic voltage control (AVC) relays is the most popular and effective voltage control device [7]. There are various control characteristics associated with OLTC such as Line Drop Compensation (LDC), time grading for accommodating operation in series of transformers, as well as a variety of circulating current compensation techniques for operation of parallel transformers.

This voltage drop along the feeder impedance is used to boost the voltage regulated at the transformer terminal therefore ensuring the correct voltage level maintains at the load where it is required. The LDC provides voltage control at a nominal load point rather than at transformer terminals as shown in Fig. 2 [8].

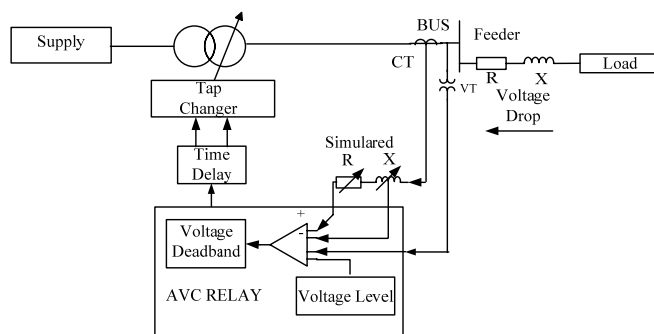

Fig. 2 AVC relay scheme with LDC

D. Distributed Generation

Control of distributed generation (DG) systems in power distribution systems is very important task that must be considered carefully. In fact the operation of distributed generation system strongly depends on the operation of the control system. Many of the distributed generation systems are connected to the grid via power electronic converters to improve the system integrity [9].

The connection of DG to distribution systems modifies voltage levels at customer's end and introduces different degrees of complexity in the voltage control strategies. In fact, according to the criterion by which DG is connected, the voltage control strategy could change [10]. Controlling network voltages, while also providing access for the increasing numbers of DG installations, is one of the most important challenges. This paper describes a novel approach to voltage control for networks with multiple connected distributed generators, which employs case-based reasoning

and online verification to select an appropriate set of control actions in the face of voltage excursions. The control measures above of OLTC control, DG curtailment and DG power factor control were made available to the CBR system investigated here. Alternative control measures for voltage control that could be incorporated into future CBR systems include energy storage [10].

The type of DG adopted in this study is a PV system which can be installed in various areas such as residential area. Since generated power of the PV system fluctuates rapidly according to the fluctuation of solar radiation, some rapid output power fluctuation might occur and result in rapid voltage fluctuation, which depends on weather conditions. In order to respond to rapid fluctuations, each interfaced inverter generated or absorbed reactive power to compensate voltage deviation from voltage control reference [11].

III. VOLTAGE CONTROL BY FACTS DEVICE

FACTS are one aspect of power electronics revolution that is taking place in all areas of electrical energy. Recent advances in the power system handling capabilities of static switches have made the use of the voltage source inverter (VSI) feasible at both transmission and distribution levels. The concepts underlying the developing of the control strategy are explained in detail and a criterion for the selection of the parameters of the various controllers involved is also given.

A. STATCOM

The static synchronous compensator (STATCOM) is based on the principle that a voltage source inverter generates a controllable AC voltage source behind a transformer leakage reactance so that the voltage difference across the reactance produces active and reactive power exchange between the STATCOM and the transmission network. The STATCOM is one of the new generation flexible AC transmission systems (FACTS) devices with promising applications in future.

The most advanced solution to compensate reactive power is the use of a Voltage Source Converter (VSC) incorporated as a variable source of reactive power. These systems offer several advantages compared to standard reactive power compensation solutions [12].

The STATCOM is appropriate for voltage control since it may rapidly inject or absorb reactive power to stabilize voltage excursions, and has been widely proven in industrial applications. Several prototype installations of STATCOM are currently in operation. However, a STATCOM/ESS combination can provide a better dynamic performance than a stand-alone STATCOM. The fast and independent control of both active and reactive power of the STATCOM/ESS system makes it the ideal candidate for many applications in the electric power systems as shown in Fig. 3.

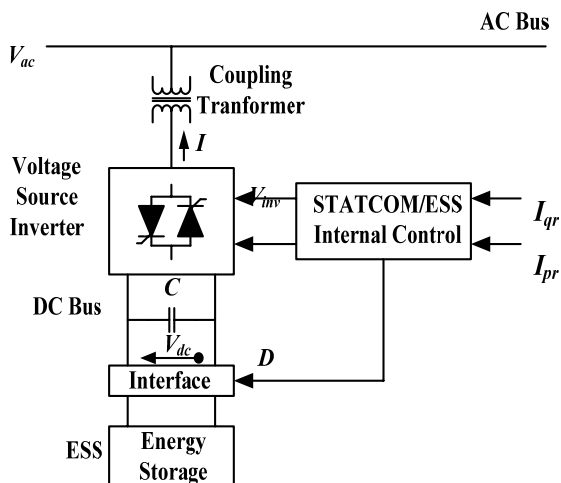

Fig. 3 Static synchronous compensator

B. Shunt Var Compensation

Voltage control capability of SVCs is decided by their var reserves, regulation slopes and available margins. In this paper, a sensitivity model for var dispatch is proposed to restore the var reserve of SVC while keeping desirable voltage profile and the control capability of SVCs is defined by the available control margin, the slopes, the reference voltage, the static voltage characteristic of the system as shown in Fig. 4. [13].

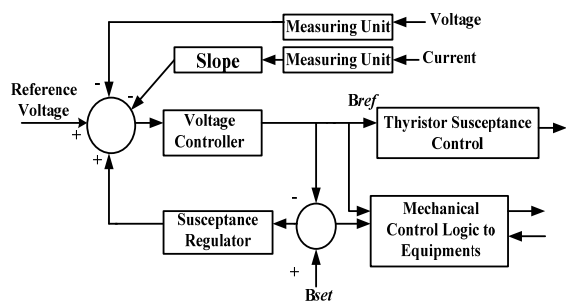

Fig. 4 The control diagram of SVC

Thyristor-Controlled Series Compensation (TCSC) is one of the important FACTS devices which come under series compensation technique in the line intended to decrease the line reactance there by maintain flat voltage profile and increase the power transfer capacity of the line as shown in Fig. 5 [14], [15].

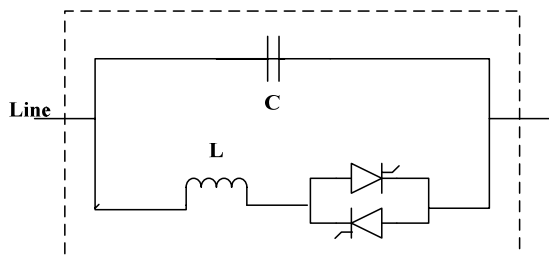

Fig. 5 Thyristor-Controlled Series Compensation

The TCSC model is incorporated with the generator shaft equations, to take into account the nonlinearities of both generator and thyristor switching. The equations are then linearized and the eigenvalues of the linearized system are computed to evaluate the system stability.

IV. CONCLUSION

The influence due to the concept of Smart Grid has many potential opportunities for the OLTC control schemes. Naturally, these schemes build on the previous techniques that are used for OLTC control and will have a significant influence on the development of voltage regulation in distribution networks. The reactive control relationship with on-load tap-changing transformer control has been illustrated and increased stress in tap changing. Voltage control ability is discussed by controlling active and reactive power of distributed generators in distribution system. Although the voltage control ability by DGs has been discussed in many papers, quantitative evaluation of the ability has not been clearly. However, in the situation that many distributed generators are connected to a power distribution system, we must utilize them as control resources for the power systems operation. The FACTS device is an instrumental for support in the power system when system have problem such as voltage drop in power system. The FACTS device will be increase curve and flexible of power system.

REFERENCES

- [1] C. Gao, and M. A. Redfern, "A review of voltage control techniques of network with distributed generations using on-load tap changer transformers, 45th Universities Power Engineering Conference (UPEC), 2010.
- [2] P. M. S. Carvalho, Pedro F. P. Correia, and L. A. F. Ferreira, "Distributed reactive power generation control for voltage rise mitigation in distribution networks," IEEE Transaction on Power System, vol. 23, no. 2, May. 2008.
- [3] Z. Dong, et al., "Capacitor switching and network reconfiguration for loss reduction in distribution system," in Proc Power Engineering Society General Meeting Conf., pp. 1-6, 2006.
- [4] C. T. Su, and C. S. Lee, "Modified differential evolution method for capacitor placement of distribution systems," in Proc. Transmissions and Distribution Conf., pp. 208-213, 2002.
- [5] Yuan-Yin Hsu, and Wah-Chun Chan, "Coordinate frequency and voltage control of synchronous generation," IEEE Transaction on aerospace and Electronic System, vol. 23, no. 1, Jan. 1987.
- [6] A. R. Hason, T. S. Martis, and A. H. M. Sadrul, "Design and implementation of fuzzy controller based automatic voltage regulator for a synchronous generation," IEEE Transaction on Energy Conversion, vol. 9, no. 3, Sept. 1994.
- [7] P. Chiradeja, R. Ramakumar, "An approach to quantify the technical benefits of distributed generation," IEEE Trans Energy Conversion, vol. 19, no. 4, pp. 764-773, 2004.
- [8] H. A. Gil and G. Joos, "Models for quantifying the economic benefits of distributed generation," IEEE Transaction on Power Systems, vol. 23, no. 2, pp. 327-335, May. 2008.
- [9] M. P. Lalitha, et al., "Optimal DG placement for minimum real power loss in radial distribution systems using PSO," Journal of Theoretical and Applied Information Technology, pp. 107-116, 2010.
- [10] K. Tanaka, M. oshiro, S. Toma, A. Yona, and C. H. Kim, "Decentralised control of voltage in distribution systems by distributed generation," IET Gener. Transm. Distrib., vol. 4, no. 11, pp. 1251-1260, 2010.
- [11] A. Hajizadeh, and M. A. Golkar, "Intelligent robust control of hybrid distributed generation system under voltage sag," Expert systems with applications, vol. 37, issue 12, pp. 7627-7638, Dec. 2010.

- [12] H. F. Wang. "Interaction and multivariable design of STATCOM AC and DC voltage control." *Electrical power energy system*, vol. 25, no. 5, pp. 387–394, Jan. 2003.
- [13] L. Shenghu, M. Ding, J. Wang, and W. Zhang, "Voltage control capability of SVC with var dispatch and slopesetting." *Electrical power energy system*, vol. 79, issue 5, pp. 818–825, May. 2009.
- [14] S. K. Tso, J. Liang, and X. X. Zhou, "Coordinate of TCSC and SVC for improvement of power system performance with NN-base parameter adaptation," *International Journal of electrical power and energy systems*, vol. 21, issue 4, pp. 235 – 244, May 1999.
- [15] P. C. Srivastava, A. Ghosh, and S. V. J. Kumar, "Model - base control design of a TCSC-compensate pwer system," *International Journal of electrical power and energy systems*, vol. 21, no. 4, pp. 299 – 307, May 1999.

Somkieat Thongkeaw received his M.Eng in Electrical Engineering from Rajamangala University of Technology Thanyaburi, Pathumthani, Thailand in 2010. He is currently a lecturer at the Department of Electrical Engineering, Faculty of Engineering Rajamangala University of Technology Phra Nakhon (RMUTP), Bangkok, Thailand. His research interests include power system operation, and renewable energy.

Manat Boonthienthong received his M.S.Tech.Ed. in Technical Education Technology from King Mongkut's University of Technology North Bangkok (KMUTNB), Thailand. He is currently a lecturer at the Department of Electrical Engineering, Faculty of Engineering Rajamangala University of Technology Phra Nakhon (RMUTP), Bangkok, Thailand. His research interests include electronics engineering and powers system planning.