

Reliability Improvement with Optimal Placement of Distributed Generation in Distribution System

N. Rugthaicharoencheep, T. Langtharthong

Abstract—This paper presents the optimal placement and sizing of distributed generation (DG) in a distribution system. The problem is to reliability improvement of distribution system with distributed generations. The technique employed to solve the minimization problem is based on a developed Tabu search algorithm and reliability worth analysis. The developed methodology is tested with a distribution system of Roy Billinton Test System (RBTS) bus 2. It can be seen from the case study that distributed generation can reduce the customer interruption cost and therefore improve the reliability of the system. It is expected that our proposed method will be utilized effectively for distribution system operator.

Keywords—Distributed generation Optimization technique Reliability improvement, Distribution system.

I. INTRODUCTION

THE distribution system is an important part that provides the final link between the utility and customers. In practice, most distribution systems have a single-circuit main feeder and are configured radially. The radial distribution system is widely used because of its simple design, generally low cost and supportive protection scheme. This configuration suggests that all components between a load point and the supply point should completely operated and therefore poor reliability can be expected as the failure of any single component causes the load points to be disconnected. An ideal alternative on electric distributions to electric users is the installation of a small sized generator or commonly known as distributed generation (DG) [1].

DG is a small sized generator connected in parallel with the distribution system. DG is expected to play an increasing role in emerging electric power systems. Studies have predicted that DG will be a significant percentage of all new generation going on line. There are several different types of resources and technologies that can be used for DG such as wind, solar, fuel cells, hydrogen, and biomass. DG can result in a network operation and planning practices with economic implications. The benefits of DG are classified into two groups: technical and economics [2]. For example, loss, voltage profile, reliability of supply, maintenance costs, and network connection reinforcement costs can be affected by the connection of DG to the distribution system [3], [4]. Electric utilities, therefore, can benefit from the installation of DG.

N.Rugthaicharoencheep is with Department of Electrical Engineering, Faculty of Engineering, Rajamangala University of Technology Phra Nakhon, Bangkok, Thailand (e-mail: nattachote.r@rmutp.ac.th).

T. Langtharthong is with Department of Electrical Engineering, Faculty of Engineering, Rajamangala University of Technology Phra Nakhon, Bangkok, Thailand (e-mail: thong.l@rmutp.ac.th).

Distribution system reliability assessment can, in general, be divided into the two basic tasks of assessing past performance and predicting future performance. Predicting reliability performance is usually concerned with the supply adequacy at the customer load points [5]. The conventional approach to teaching distribution system reliability evaluation, in either a university or industry based setting, is to use the basic analytical equations to calculate load point failure rates, average outage durations and average annual outage times.

The technique employed to solve the minimization problem is based on a developed Tabu search algorithm and reliability worth analysis. The Tabu algorithm systematically searches solutions expressed in forms of the location and size of DGs. The solution obtained will then be passed to reliability worth analysis to evaluate the quality of the solution. The process is repeated until the best solution has been found. The developed methodology is tested with a distribution system of Roy Billinton Test System (RBTS) bus 2.

II. TABU SEARCH

Tabu search is a meta-heuristic that guides a local heuristic search strategy to explore the solution space beyond local optimality [6]. The basic idea behind the search is a move from a current solution to its neighborhood by effectively utilizing a memory to provide an efficient search for optimality. The memory is called “Tabu list”, which stores attributes of solutions. In the search process, the solutions are in the Tabu list cannot be a candidate of the next iteration. As a result, it helps inhibit choosing the same solution many times and avoid being trapped into cycling of the solutions [7]. The quality of a move in solution space is assessed by aspiration criteria that provide a mechanism for overriding the Tabu list. Aspiration criteria are analogous to a fitness function of the genetic algorithm and the Boltzman function in the simulated annealing as shown in Fig. 1.

In the search process, a move to the best solution in the neighborhood, although its quality is worse than the current solution, is allowed. This strategy helps escape from local optimal and explore wider in the search space.

A Tabu list includes recently selected solutions that are forbidden to prevent cycling. If the move is present in the Tabu list, it is accepted only if it has a better aspiration level than the minimal level so far [8]. Fig. 2 shows the main concept of a search direction in Tabu search.

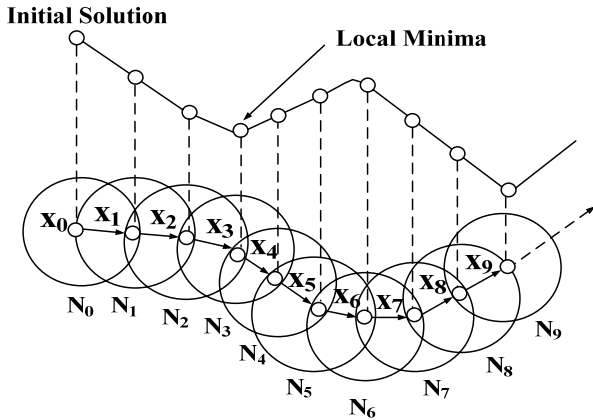

Fig. 1 Search direction of Tabu search

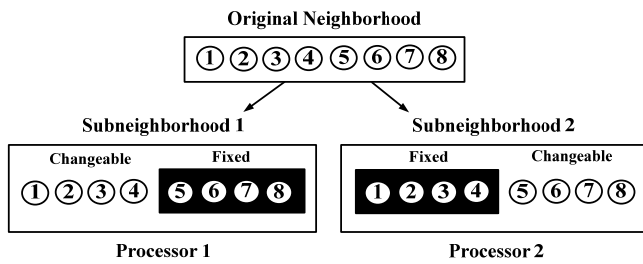

Fig. 2 Search direction of Tabu search

III. DISTRIBUTION SYSTEM RELIABILITY

The basic distribution system reliability indices at a load point are average failure rate λ , average outage duration r , and annual outage duration U . With these three basic load point indices, the following system reliability indices can be calculated [8].

Average interruption frequency index (SAIFI)

$$SAIFI = \sum \frac{\lambda_i N_i}{N_i} \quad (1)$$

System average interruption duration index (SAIDI)

$$SAIDI = \sum \frac{U_i N_i}{N_i} \quad (2)$$

Customer average interruption duration index (CAIDI)

$$CAIDI = \sum \frac{U_i N_i}{\lambda_i N_i} \quad (3)$$

Average service availability index (ASAI)

$$ASAI = \frac{\sum N_i \times 8760 - \sum U_i N_i}{\sum N_i \times 8760} \quad (4)$$

Average service unavailability index (ASUI)

$$ASUI = 1 - ASAI = \frac{\sum U_i N_i}{\sum N_i \times 8760} \quad (5)$$

Energy not supplied index (ENS)

$$ENS = \sum L_{a(i)} U_i \quad (6)$$

Average energy not supplied index (AENS)

$$AENS = \frac{\sum L_{a(i)} U_i}{\sum N_i} \quad (7)$$

where

λ_i = failure rate of contingency i

N_i = total number of load points i

U_i = annual outage duration i

$L_{a(i)}$ = failure rate of contingency i

A basic approach to quantifying the worth of electric service reliability is to estimate customer interruption costs due to electric power supply interruptions. One convenient way is an interpretation of customer interruption costs in terms of customer damage functions. The customer outage cost ($ECOST$) is calculated from reliability indices of the load point and customer damage function [9]-[10].

IV. PROBLEM FORMULATION

The objective is to minimize the customer outage cost that can be written as follows:

$$\text{Minimize } ECOST = \sum_{h=1}^{n_h} \sum_{i=1}^{n_i} (L_{a(i)} C_{hi} r_h \lambda_h) \quad (8)$$

where

$L_{a(i)}$ = average load connected to load point i

C_{hi} = outage cost (\$/kW) of customer due to contingency h

λ_h = failure rate of contingency h

r_h = average outage time of contingency h

n_h = number of contingencies h

n_i = total number of load points i

Constraints:

1) Power flow equations:

$$P_k = \sum_{i=1}^{N_B} |Y_{ik} V_i V_k| \cos(\theta_{ik} + \delta_k - \delta_i) \quad (9)$$

$$Q_k = -\sum_{i=1}^{N_B} |Y_{ik} V_i V_k| \sin(\theta_{ik} + \delta_k - \delta_i) \quad (10)$$

2) Voltage of each bus k must be within specified limits:

$$V_k^{\min} \leq V_k \leq V_k^{\max} \quad (11)$$

3) Current transfer capability of feeders l :

$$I_l \leq I_l^{\max} ; l \in \{1, 2, \dots, N_l\} \quad (12)$$

4) Maximum number of DGs (n_{DG}) to be installed:

$$\sum_{k=1}^{N_B} e_{jk} \leq n_{DG} \quad j \in \{1, 2, \dots, N_C\} \quad (13)$$

5) Maximum installed capacity of DGs:

$$\sum_{k=1}^{N_B} \sum_{j=1}^{N_C} C_j \cdot e_{jk} \leq G \quad (14)$$

6) Decision variables for the installation of a DG:

$$e_{jk} = \begin{cases} 0 & \text{if the DG is not installed at bus } k \\ 1 & \text{if the DG is installed at bus } k \\ & \text{with the capacity at step } j \end{cases} \quad (15)$$

7) Only one DG can be installed at one position

$$\sum_{j=1}^{N_C} e_{jk} \leq 1 \quad k \in \{1, 2, \dots, N_B\} \quad (16)$$

where

- P_k = power active power at bus k
- Q_k = power reactive power at bus k
- N_B = number of buses
- Y_{ik} = element (i, k) in bus admittance matrix
- θ_{ik} = angle of Y_{ik}
- δ_k = voltage angle at bus k
- N_l = number of feeders
- V_k^{\min} = minimum voltage at bus k
- V_k^{\max} = maximum voltage at bus k
- I_l = current flow in feeder l
- I_l^{\max} = maximum current capability of feeder l
- N_B = number of buses
- N_C = number of capacity steps of a DG
- C_j = capacity at step j of DG
- G = maximum total installed capacity
- N_C = number of capacity steps of a DG
- C_j = capacity at step j of DG
- e_{jk} = decision variable for installation of a DG at bus k with the capacity at step j

V. SOLUTION ALGORITHM

The solution algorithm for the problem is described step by step as follows:

Step 1: Randomly select a feasible solution from the search space: $S_0 \in \Omega$. Set the size of a Tabu list, maximum

iteration and iteration index $m=1$.

Step 2: Let the initial solution obtained in step 1 be the current solution and the best solution: $S_{\text{best}} = S_0$, and $S_{\text{current}} = S_0$.

Step 3: Perform a power flow analysis to determine whether the current solution satisfies the constraints defined in (9) and (10). A penalty factor is applied for constraint violation.

Step 4: Calculate $ECOST$ using (8) with consideration of load point restoration.

Step 5: Calculate the aspiration level of S_{best} : $f_{\text{best}} = f(S_{\text{best}})$. The aspiration level is the sum of $ECOST$ and a penalty function.

Step 6: Generate a set of solutions in the neighborhood of S_{current} . This set of solutions is designated as S_{neighbor} .

Step 7: Calculate the aspiration level for each member of S_{neighbor} , and choose the one that has the highest aspiration level, $S_{\text{neighbor_best}}$.

Step 8: Check whether the attribute of the solution obtained in step 7 is in the Tabu list. If yes, go to step 9, or else $S_{\text{current}} = S_{\text{neighbor_best}}$ and go to step 10.

Step 9: Accept $S_{\text{neighbor_best}}$ if has a better aspiration level than f_{best} and set $S_{\text{current}} = S_{\text{neighbor_best}}$, or else select a next-best solution that is not in the Tabu list to become the current solution.

Step 10: Update the Tabu list and set $m = m+1$.

Step 11: Repeat steps 6 to 10 until the specified maximum iteration has been reached and report the best solution.

Summing up, the performance of Tabu search depends on a proper choice of the neighbor of a solution, on the number of iterations for which a move is kept as Tabu, on the best combination of short- and long-term memory and on the best balances of intensification and diversification mechanism [10]. The solution algorithm for the problem is described step by step as shown in Fig. 3.

VI. CASE STUDY

The developed Tabu search algorithm is tested with a distribution system of RBTS bus 2 [11] to minimize the customer outage cost. There are 4 feeders and 22 load points. The peak loading level of bus 2 is 20 MW. The configuration of the system is shown in Fig. 4. The maximum iteration for Tabu search is 100. The minimum and maximum voltages for each bus are 0.95 p.u. and 1.05 p.u., respectively. The sizes of DGs are 100 kW-1,500 kW. The failure of a transformer is recovered by repair. All protective devices and DGs are assumed to be fully reliable. Three cases are investigated in Table I. The results from the case study are shown in Tables II and III.

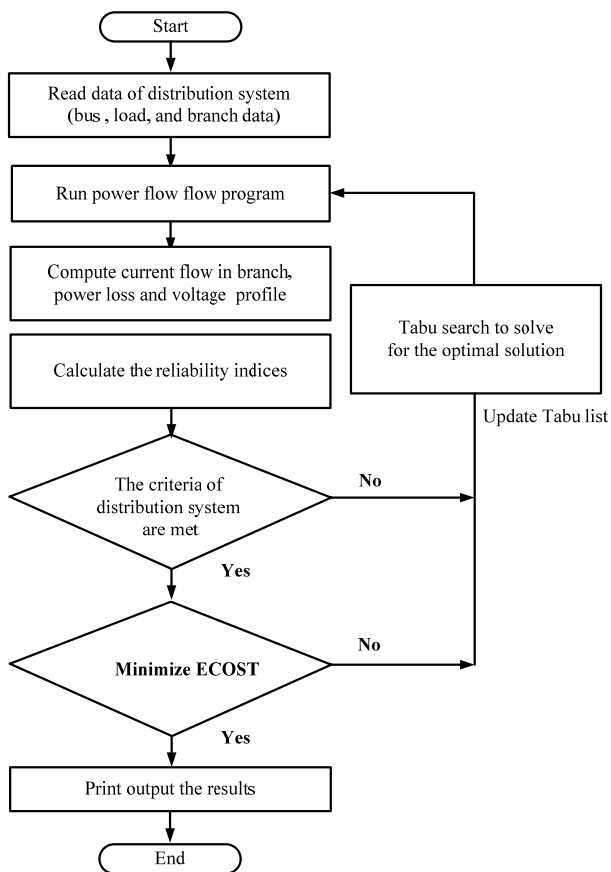

Fig. 3 Flowchart for solution algorithm

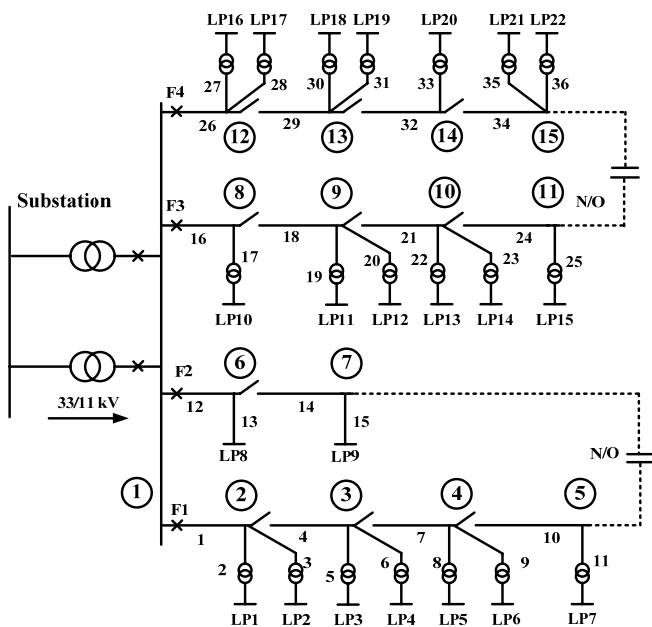

Fig. 4 RBTS bus 2 Radial Distribution system

TABLE I
CASE STUDY FOR RELIABILITY ANALYSIS

Case	Maximum number of DGs, n_{DG} (unit)	Total installed capacity, G (kW)
1	-	-
2	1	≤ 1000
3	3	≤ 2000
4	3	≤ 3000
5	4	≤ 4000

TABLE II
OPTIMAL PLACEMENT AND SIZING OF DGs

Case	Location of DG (bus)	Capacity of DG installed (kW)	Total capacity of DG (kW)
1	-	-	-
2	5	500	500
3	3, 5, 11	100, 500, 500	1100
4	10, 11, 15	1000, 600, 1200	2800
5	5, 10, 12, 15	600, 1200, 200, 1200	3200

All the cases have the same SAIFI because this index depends only on the reliability of components (e.g., lines, transformers) and is not affected distributed generations to be installed. We can see that the overall reliability indices of cases 2 to 5 in Table III are improved compared with that of case 1 (base case). In cases 2, 3, 4 and 5, where the number of DGs is limited at 1, 2, 3 and 4 unit respectively, see reductions in the system ECOST.

TABLE III
RESULT OF CASE STUDY FOR RELIABILITY INDICES

Reliability indices	Cases				
	1	2	3	4	5
SAIFI (interruptions/customer yr)	0.2482	0.2482	0.2482	0.2482	0.2482
SAIDI (hours/customer yr)	3.7321	3.7290	3.7261	3.7253	3.7251
CAIDI (hours/customer interruption)	15.036	15.024	15.012	15.009	15.008
ASAI	0.9996	0.9996	0.9996	0.9996	0.9996
ASUI	0.0004	0.0004	0.0004	0.0004	0.0004
ENS (kWh/year)	40,775.30	40,509.70	40,256.00	39,455.40	39,443.60
AENS (kWh/customer/year)	21.37	21.23	21.10	20.68	20.67
ECOST (\$/year)	49,922.30	47,552.80	45,288.70	43,262.90	43,157.60
ECOST reduction (%)	-	4.75	9.28	13.34	13.55

It is very interesting to note that the constraint given in (14) is binding for these four cases. The reason is that to minimize the system ECOST, as many DGs as possible should be installed. Distribution system of RBTS bus 2 with distributed generation for case 5 shown in Fig. 5 It is observed that a DG, if its size is large enough, tends to be installed at the end of a feeder.

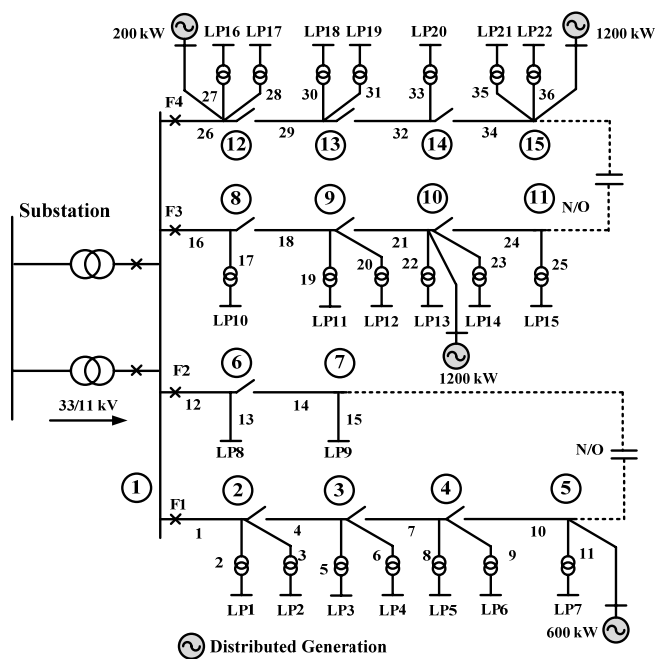

Fig. 5 Distribution system of RBTS bus 2 with distributed generation for case 5

VII. CONCLUSION

The search for the best compromise among the objectives is achieved by Tabu search technique for optimal placement and sizing of distributed generation in distribution systems. Employing DG in a distribution system results in several benefits such as increased overall system efficiency. The effectiveness of the proposed method was demonstrated by a case study of a distribution network of RBTS bus 2. It can be seen from the case study that distributed generation can reduce the customer interruption cost and therefore improve the reliability of the system. It is expected that our proposed method will be utilized effectively for distribution system operator.

ACKNOWLEDGMENT

The authors would like to express his gratitude to Rajamangala University of Technology Phra Nakhon, Thailand for support.

REFERENCES

- [1] D. T. Wang, L. F. Ochoa, and G. P. Harrison, "DG impact on investment deferral: network planning and security of supply," *IEEE Trans. Power System*, vol. 25, no. 2, pp. 1134-1141, May 2010.
- [2] J. Zhang, H. Cheng, and C. Wang, "Technical and economic impacts of active management on distribution network," *Electrical Power and Energy Systems*, vol. 31, pp. 130-138, 2009.
- [3] J. Mutale, "Benefits of active management of distribution networks with distributed generation," in *Proc. Power System Conf. and Exposition*, pp. 601 - 606, 2006.
- [4] L. F. Ochoa, A. P. Feltrin, and G. P. Harrison, "Evaluating distributed time-varying generation through a multiobjective index," *IEEE Trans. Power Delivery*, vol. 23, no. 2, pp. 1132-1138, April 2008.
- [5] R. Billinton, and R. N. Allan, "Reliability evaluation of power systems," pitman advanced publishing program, 1984.
- [6] D. Bernaand, and A. Cigdem, "Simulation optimization using tabu search," in *Proc. Winter Simulation Conference*, pp. 805-810, 2000.

- [7] F. Glover, Tabu search-part I. *ORSA J. Computing*, vol. 1, no. 3, 1989.
- [8] M. Hiroyuki, and O. Yoshihiro, "Parallel tabu search for capacitor placement in radial distribution system," in *Proc. Power Engineering Society Winter Meeting*, vol. 4, pp. 2334-2339, 2000.
- [9] L. Goel, and R. Billinton, "Procedure for evaluating interrupted energy assessment rates in an overall electric power system," *IEEE Trans. Power Systems*, vol. 6, no. 4, pp.1398-1403, 1991.
- [10] L. Goel, and R. Billinton, "Basic data and evaluation of distribution system reliability worth," in *Proc. Computer, Power and Communication Systems in a Rural Environment*, pp. 271-277, 1991.
- [11] Y. J. Jeon, and J. C. Kim, Application of simulated annealing and tabu search for loss minimization in distribution systems, *Electrical Power and Energy Systems*, vol. 26, no.1, pp. 9-18, 2004.

Nattachote Rugthaicharoencheep (M'10) received his Ph.D. in Electrical Engineering from King Mongkut's University of Technology North Bangkok (KMUTNB), Thailand in 2010. He is currently a lecturer at the Department of Electrical Engineering, Faculty of Engineering Rajamangala University of Technology Phra Nakhon (RMUTP), Bangkok, Thailand. His research interests include power system operation, optimization technique, and distributed generation.

Thong Lantharthong received his M.Eng in Electrical Engineering from Rajamangala University of Technology Thanyaburi, Pathumthani, Thailand in 2010. He is currently a assistant professor at the Department of Electrical Engineering, Faculty of Engineering Rajamangala University of Technology Phra Nakhon (RMUTP), Bangkok, Thailand. His research interests include power system operation, optimization technique, and distributed generation.