

Simulating Voltage Sag Using PSCAD Software

Kang Chia Yang, Hushairi HJ Zen, Nur Ikhmar@Najemeen Binti Ayob

Abstract—Power quality is used to describe the degree of consistency of electrical energy expected from generation source to point of use. The term power quality refers to a wide variety of electromagnetic phenomena that characterize the voltage and current at a given time and at a given location on the power system. Power quality problems can be defined as problem that results in failure of customer equipments, which manifests itself as an economic burden to users, or produces negative impacts on the environment. Voltage stability, power factor, harmonics pollution, reactive power and load unbalance are some of the factors that affect the consistency or the quality level. This research proposal proposes to investigate and analyze the causes and effects of power quality to homes and industries in Sarawak. The increasing application of electronics equipment used in the industries and homes has caused a big impact on the power quality. Many electrical devices are now interconnected to the power network and it can be observed that if the power quality of the network is good, then any loads connected to it will run smoothly and efficiently. On the other hand, if the power quality of the network is bad, then loads connected to it will fail or may cause damage to the equipments and reduced its lifetime. The outcome of this research will enable better and novel solutions of poor power quality to small industries and reduce damage of electrical devices and products in the industries.

Keywords—Power quality, power network, voltage dip.

I. INTRODUCTION

IN recent years, there has been an increased emphasis and concern for the quality power delivered to factories, commercial establishments and residences. Much of the equipment in use today is susceptible to damage or service interruptions during poor power quality events [1]. There has been a proliferation of non linear loads in electrical installations due to the great development of electronic equipment. As widely known, everyone using computer whether at home or office has experienced a computer shutdown and reboot, due to power outage which result in loss of working hours. This is caused by the poor power quality on the 240V line. Quality of Electricity is very essential for modern industry. Almost all offices and industrial equipment depend on electricity in some form or the other. Heavy industrial equipments like non-linear variable speed drives powered through power electronic converters may cause power disturbances. Due to this, power quality is becoming a mounting concern in the electric power industry. Power quality problems encompass a wide range of disturbances and

conditions on the power system. They include everything from very fast voltage transients to long duration outages. It also includes steady state phenomena such as flicker and noisy waveforms. The power system can also experience momentary interruptions like voltage sag and swell. These problems are sometimes unpredictable, because it is difficult to predict when and where it might happen. Poor electric power quality basically was limited to interruptions in the energy supply, however currently many other factors influence the quality of energy, since the number of sensitive loads is increasing at the same time that the non-linear current consumption augments the voltage waveform distortion. The Institute of Electrical and Electronics Engineers (IEEE) has attempted to address this problem by developing a standard that includes definitions of power disturbances. This standard, IEEE Standard 1159-1995, IEEE Recommended Practice for Monitoring Electrical Power Quality, defines disturbances as: interruptions, sags and swells, long duration variations, impulsive transients, oscillatory transients, harmonic distortion, voltage fluctuations, and noise. Therefore the power quality monitoring standard is very effective to prevent future problems that might cause damage of equipments or premature aging of the installation components like transformers, circuit breakers. The electrical wiring might also be affected. Monitoring of electrical power quality is perhaps the most important, step in identifying and solving power problems [2].

II. PROBLEMS STATEMENTS

The widespread use of electronics devices ranging from equipment at home to the control of huge and costly industrial processes has raised the awareness of power quality issues and concerns over the last few years. Low power quality issue has seriously affected the small industry and resulted in financial loss due to the stop of production and wasted electrical power distributed to homes, especially the non-linear characteristics of various offices and industrial equipments connected to the power grid which might cause electrical disturbances. Some electronic equipment, beyond consuming distorted currents, also requires rigorous parameters of electric energy, meaning that a small disturbance may cause malfunction or even in the most extreme cases, cause serious damage. Circuit Breakers tripping for no apparent reason, computer malfunction, communication failure, conductor failure of heating, electronic equipment shutting down, flickering of fluorescent lights, fuse blowing, motor failures and overheating are some of the effect due to poor power quality. All this phenomena potentially lead to inefficient running of installations, system down time and reduced equipment life and consequently high installation running costs. Study needs to be carried out to investigate the

Kang Chia Yang is lecturer at the Polytechnics Mukah Sarawak, Malaysia (phone: +60124359716; e-mail: kangcy87@hotmail.com).

Dr. Hushairi is deputy dean for postgraduate and research at Faculty Engineering University Malaysia Sarawak.

Nur Ikhmar@Najemeen Binti Ayob is a lecturer at Polytechnics Mukah Sarawak (Phone: +0176964157; e-mail:meen_naja83@yahoo.com).

causes of the poor power quality so that solutions can be designed. It also aims to give readers a better insight in the benefits that may be gained by having good Power Quality in installations.

III. OBJECTIVES

This proposed paper aims to simulate the power quality phenomena using an analytical tool, Power System Computer Aided Design (PSCAD) conducted at one of the substation at small industry and the impacts they may present to power quality. It also attempts to study the power quality problem such as voltage sag on a power line that may be caused by typical loads using computer models paving the way to identify the source of the problem. Reliability of supply and voltage quality is to be studied by using method of monitoring the power waveform. Power quality monitoring is an essential service many utilities perform for their industrial and other key commercial customers. The results of this study will contribute knowledge for researchers to design a more efficient power to reduce power waste either as a result of reactive or capacitive losses, harmonic distortion and other losses such as load imbalance. Other than that, it also contributes to overcome problems such as energy loss and malfunction of electrical equipment due to the poor power quality.

IV. LITERATURE REVIEW

Harmonic distortion is one of the main factors that contributes to poor power quality and was observed when the sinusoidal voltages or currents have frequencies that are integer multiples of the fundamental frequency being supplied. This distortion is continuous and the most common result is unwanted heating in the electrical system. It is interesting to note that some of the equipment that is sensitive to power quality disturbances usually is equipment that generates harmonics. Equipment such as adjustable speed drives, computer power supplies, UPS equipment and other power electronics create harmonic currents. Harmonic currents generate harmonic voltages as they pass through the system impedance. In addition to power electronics, arcing equipment such as arc furnaces and welders are also major contributors in the harmonic arena [3].

The monitoring of Electric Power Quality is an important tool to detect problems that may be affecting the equipment or the electrical installation. An effective Power Quality Monitoring may also prevent future problems that might cause damage of equipments or premature aging of the installation components like transformers, circuit breakers even the electrical wiring can be affected. Power Quality Monitor prototype was developed at Energy and Power Electronics laboratory of the University of Minho. This prototype is assembled in a strong plastic case with easy to connect plugs for power and sensors and a built-in 14 inch TFT monitor. To allow the Electric Power Quality Monitor to record the consequences of the failure and also the consequences of the return of the electric power, the prototype was equipped with a

backup battery, so, it continues working in the occurrence of power outages. The software of the Electric Power Quality Monitor is constituted by several applications and is based in *Lab View*. The developed applications allow the equipment to function like a digital oscilloscope, analyze harmonic contents, detect and record voltage distortions (sags, swells, interruptions, wave shapes), measure energy, power, voltage and current unbalance, power factor, record and watch strip charts and generate reports [4].

Harmonic field measurement is done to verify the degree of severity of harmonic distortion due to domestic non-linear loads in the distribution system [5]. There are number of solid state controlled non-linear equipments are used for domestic application such as electronic fan regulator, personnel computer, printer, etc. These non-linear loads inject harmonic currents in the network thus distorting supply voltage. In carrying out harmonic measurement, six types of domestic application were selected. All the measurements are made at 230 V using Yokogawa make clamp on type Power Analyzer. Harmonic spectrum for each load is plotted showing magnitude of each harmonic frequency that makes up a distorted waveform. The magnitude of each harmonic frequency can be expressed as a percentage of fundamental. Total harmonic distortion is defined from harmonic spectrum as the ratio of the RMS sum of all harmonic frequencies to the RMS value of the fundamental [6].

There is no single algorithm that can detect the variety of power quality anomalies. Instead, a set of algorithms is need, where each one is responsible for detection of a set of disturbances. The IT group expertise in analog to digital converters (ADCs) testing/characterization and in digital signal processing algorithms will be used in the development of power quality analyzers. The use of ADCs and digital signal processing algorithms will enable the development and implementation of instruments with great versatility which can be easily adapted to the anomalies that degrade power quality [7].

The power consumption in Brazil is constantly increasing; all electrical equipments connected to an electric power system are designed to work in a particular nominal voltage. The efficiency of industrial processes is directly related to the Power Quality (PQ) delivered to customers, since most of the equipments that compose these processes have different levels of vulnerability in relation to disturbances in the Power Quality [9]. The recent standard PRODIST forces all utilities to meet the requirements. An analysis regarding the power quality parameters covered by Prodist are steady state voltage magnitude, power factor, voltage harmonics, voltage unbalance, voltage fluctuation (flicker), voltage variation and frequency variation. The goal is to present aspects to be observed in the measurement of each parameter indicating the standard in which the measurement is based, technical characteristics, measurement methodology and criteria accuracy that must be observed [10].

Power quality becomes an emphasis of related researches. The functions of QCC are expanded and its basic types and structures are defined based on the detailed study on QCC (Quality Control Center) of the FRIENDS. The technological core of FRIENDS is called the electric power QCC (Quality Control Center), which can realize the power supply of different kinds of qualities and different kinds of electric energy forms, moreover it has the functions of information processing and control center. The supply of many kinds of electric energy qualities includes: premium quality power supply, high quality power supply and normal quality power supply. The supply of different kinds of electric energy forms includes: AC power supply and dc power supply. Thus high flexibility, high reliability, and intelligence of power supply can be achieved by QCC. The conventional distribution system with QCC is called flexible distribution system. A profound research on QCC and its key part UPQC has been present [8].

V. RESEARCH METHODOLOGY

This research proposes a study on the power quality phenomena (voltage dip) in small industries. It will be carried out in several stages: as below:

- Stage1. Surveys and interviews with engineers in small industries, record data and information that provided from them.
- Stage2. Modeling one of the substation systems in the small industry. The load data collected from industry will be used to carry out simulation using PSCAD or any other appropriate simulation tools. It will be simulated by using suitable parameters on the non-linear loads.
- Stage3. The simulation results will be used to design or recommend a solution to improve and overcome the issue of power quality in industries in Sarawak.

VI. VOLTAGE SAG CAUSE BY LARGE INDUCTION MOTOR STARTING

According to the previous research, there are two main causes of voltage sag; starting of large loads either on the affected site or by a consumer on the same circuit or faults on other branches of the network. Voltage sag can be created within an industrial complex without any influence from the utility system. These sag typically caused by starting large motors or by electrical faults inside the facility. A model of the power system at Substation No.5 in small industry will be constructed to simulate and analyze power quality problems. High starting current of the motor often lead to unwelcome voltage drops to an unacceptable value in the supply network and the high starting torque put the mechanical elements under considerable strain. Every power and source has their own impedance. When there is heavy loads at starting, voltage sag was happens on the feeders due to the large impedance. The currents for the large induction motor sometimes can be several times higher than the rated load currents due to the heavy loads. This higher currents can be represents a very high load across the electrical system. The presence of the voltage

sags has the effect of causing motor to draw more currents and results in trip of the electrical network. Fig. 1 illustrates a simple model of substation No.5 with two induction motor connects to the distribution feeder in simulation of voltage sag. They are supplied through two transformers with ratings of 0.75MVA, 11KV/415V. The voltage sag caused by the large induction motor starting at the Chiller pump room will be examined. An overlay graph with signal was measure in the feeder of the system.

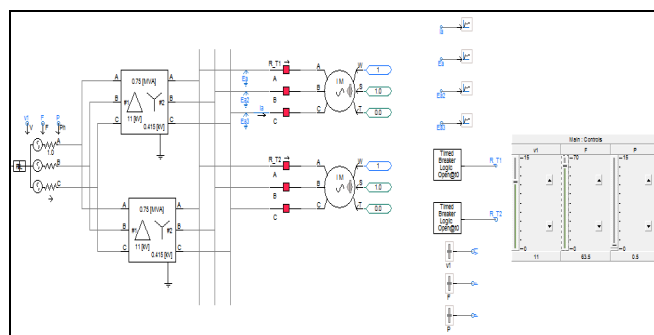

Fig. 1 Simple Large Induction Motor Starting at Substation No.5

Table I shows the computed values from the survey result to be used to present the load components and Table II shows the Transformer information. Since October year 2012, its experience 16 numbers of voltage sag conditions which those causing electrical equipments to trip suddenly and consequently stop the electrical supply from substation 5.

TABLE I
DATA OF LOAD COMPONENTS

Load Components (Chiller Pump Room)	Rated RMS phase Voltage/kV	Power Drawn (A)	Base Angular Frequency (rad/sec)	Horse Power
Induction Motor 1	0.25	660	314.16	221
Induction Motor 2	0.25	950	314.16	319

TABLE II
TRANSFORMER T1 AND T2

Transformer Information	
Transformer T1 & T2	0.75MVA, 11kV/0.415KV, 60Hz
Efficiency	98.55%
Voltage Regulation	1.38
Width (m)	2100
Depth (m)	1850
Height (m)	2100

TABLE III
VOLTAGE SAG COUNT BASED ON THE RECORD DATA

Month	Voltage Sag Count	
Year 2012	Oct	3
	Nov	2
	Dec	2
Year 2013	Jan	4
	Feb	2
	Mar	3

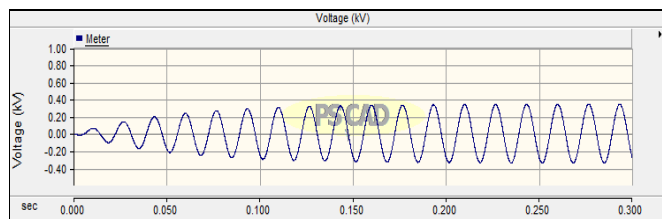
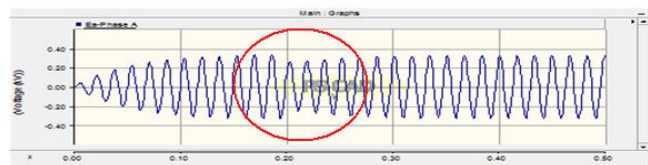

Fig. 2 A normal single phase voltage

Fig. 2 shows a normal single phase voltage which is around 339V peak to peak voltage.

VII. RESULT AND ANALYSIS

Phase A:



Phase B:

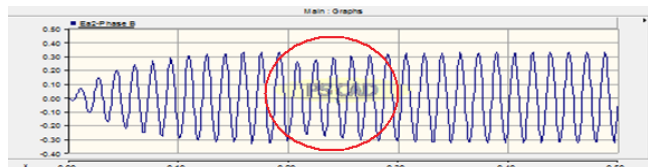

Phase C:

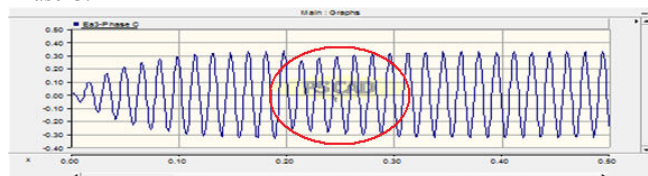

Fig. 3 Voltage Sag effect that Cause by Large Induction Motor

Fig. 3 shows the effect of voltage magnitude during starting of large induction motors on phase A, phase B and phase C. At the initial state, all the switches are opened and the induction motor is off. Once the switch is closed at 0.2s, the induction motor draw approximately seven times higher than the rated load current and the voltage is immediately decrease to 65 %. Voltage Sag start from 0.2s and will remain until it reached the nominal speed. When heavy loads are introduced at starting, there is voltage sag experience on the distribution feeder or even on the motor loads. The magnitude of the voltage sag is reduced below 90% for 0.5-60 cycles. Normally the duration of the voltage sag will be stay for several seconds. Sag magnitude maybe different depending on the network impedance and the motor power ratings. The results obtained have illustrated the effect of power quality during the starting of large induction motor. Table III shows the voltage sag count based on the previous record data and Table IV shows the result of the voltage sag magnitude in per unit (p.u).

TABLE IV
VOLTAGE SAG MAGNITUDE DUE TO LARGE INDUCTION MOTORS

Voltage Sag Magnitude (in p.u)	Phase A	Phase B	Phase C
	0.809	0.672	0.746

As seen in Fig. 4, there is no current drawn from 0 sec to 0.2sec from the induction motor. At the moment of starting large induction motor, its exhibits an instant 'hunger' of current which is approximately seven times then it rated current. The large inrush current can cause voltage sag in the local and adjacent area even if the utility line voltage remains at a constant nominal value.

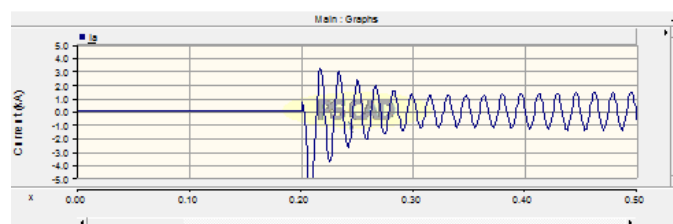

Fig. 4 Effect of current during starting of large induction motor at chiller pump room

VIII. CONCLUSION

Voltage sags are becoming an increasing concern of industrial plants due to increasing automation. Automated facilities are more difficult to restart, and the electronic controllers used are sometimes more sensitive to voltage sags than other loads. The sensitivity of industrial equipment to voltage sags varies greatly. The more sensitive equipment widens a plant's area of vulnerability to disruptive voltage sags. Simulation of voltage sag by using computer aided tools PSCAD in the power distribution system has been carry out as part of this research. Voltage sag in this research is concentrate on one of the substation in the small industry. The purpose is to find out the low power quality due to the voltage sag. The results obtained were realistic if compare with the previous research. The loading effect on the starting was causing the high starting current and leading to the voltage sag. Decreasing of the voltage magnitude on 0.2s shows that the poor power quality in the power system. Normally the sag will remain until the motor have reached their nominal speed. The results of the simulation will assist in the future study and development in the power system network. Therefore more works should be carrying out in this area so that to improve the power quality problems.

REFERENCES

- [1] K. Johnson & R. Zavadil, "Assessing the Impacts of Nonlinear Loads on Power Quality in Commercial Buildings—An Overview," *Conference Record of the 1991 IEEE Industry Applications Society Annual Meeting*, September 28–October 4, 1991, pp. 1863–1869.
- [2] M. Negnevitsky, J. Milanovic & M. Green, 1997, *Survey of Power Quality in Tasmania*, Dept. of Electr. Eng. & Computer. Sci., Tasmania Univ., Hobart, Tas
- [3] John F. Hibbard, *Understanding and Correcting Harmonic Distortion*, PCIM Power Quality '92 Conference and Exhibition, September, 1992.

- [4] Renato Alves, Pedro Neves, D. Gonçalves, J. G. Pinto, José Batista, João L. Afonso *Electric Power Quality Monitoring Results in Different Facilities*
- [5] M. S. Lalli & I. P. S. Paul, *Field Measurement of Power Quality in Steel Rolling Mills*, Centre Power Research Institute (CPRI), Bangalore. Pp.279-282
- [6] J D. C. Bhonsle, R. B. Kelkar, *Harmonics Pollution Survey and Simulation of Passive Filter Using Matlab*
- [7] A. Lakshmikanth & M. M. Morcos, *A Power Quality Monitoring System: A Case Study in DSP-Based Solutions for Power Electronics*, IEEE Trans. on Instrum. and Measurement, vol. 50, pp. 724-730, 2001
- [8] Peng Li, Qian Bai, Baoli Zhao & Yihan Yang, 2005 *Power Quality Control Center and Its Control Method* IEEE/PES Transmission and Distribution Conference & Exhibition: Asia and Pacific Dalian, China.
- [9] P. Pohjanheimo & M. Lehtonen, *Equipment Sensivity to Voltage Sags – Tests Results for Contactors, PCs and Gas Discharge Lamps* IEEE/PES – 10th. Chapter 9.
- [10] G. S. Wojichowski, C. D. P. Crovato, & R. C. Leborgne. 2012 *Proposal of a Power Quality Analyzer for the new Brazilian Distribution Procedures (PRODIST)*