

A new approximate procedure based on He's variational iteration method for solving nonlinear hyperbolic wave equations

Jinfeng Wang, Yang Liu and Hong Li

Abstract—In this article, we propose a new approximate procedure based on He's variational iteration method for solving nonlinear hyperbolic equations. We introduce two transformations $q = u_t$ and $\sigma = u_x$ and formulate a first-order system of equations. We can obtain the approximation solution for the scalar unknown u , time derivative $q = u_t$ and space derivative $\sigma = u_x$, simultaneously. Finally, some examples are provided to illustrate the effectiveness of our method.

Keywords—Hyperbolic wave equation; Nonlinear; He's variational iteration method; Transformations

I. INTRODUCTION

IN this article, we consider the following hyperbolic wave equation

$$u_{tt} - u_{xx} + \mathfrak{N}u = f(x, t), \quad (1)$$

where \mathfrak{N} is a nonlinear operator.

The hyperbolic wave equations are a high-order partial differential equations with mixed partial derivative with respect to time and space, which describe heat and mass transfer, reaction diffusion and nerve conduction, and other physical phenomena. In recent years, a lot of researchers have studied and proposed many numerical methods for second-order hyperbolic wave equations, such as finite element methods [1], [2], [3], mixed finite element methods [4], [5], [6], [7], [8], [9], [10], [11], the reduced finite volume element formulation based on POD method [12], He's variational iteration method [13], [14], [15], [16], [17], [18], [19], He's homotopy perturbation method [16] and Adomian decomposition method [20], [21].

In 1997, He [22] proposed the variational iteration method (VIM) for some nonlinear partial differential equations. From then on, the He's VIM has been applied to solve many linear and nonlinear differential equations [23], [24], [25], [26], [27], [28]. In [13], [14], [15], [16], [17], [18], [19], He's variational iteration method were studied and analysed for second-order hyperbolic wave equations.

Jinfeng Wang is with the School of Statistics and Mathematics, Inner Mongolia University of Finance and Economics, Hohhot 010070, China (e-mail: w45j85f@163.com).

Yang Liu is with the School of Mathematical Sciences, Inner Mongolia University, Hohhot 010021, China (corresponding author to provide phone: 086-471-4991650; fax: 086-471-4991650; e-mail: mathliuyang@yahoo.cn).

Hong Li is with the School of Mathematical Sciences, Inner Mongolia University, Hohhot 010021, China (corresponding author to provide phone: 086-471-4991923; fax: 086-471-4991650; e-mail: smslh@imu.edu.cn).

In this article, our aim is to propose a new approximate procedure based on He's variational iteration method (VIM) to find approximate solutions for the second-order hyperbolic equations. We introduce two transformations $q = u_t$ and $\sigma = u_x$ and formulate a first-order system of equations, which has three equalities: correction functional, integral equation and differential equation. Our method can obtain the approximation solution for the scalar unknown u , time derivative $q = u_t$ and space derivative $\sigma = u_x$, simultaneously.

II. NEW PROCEDURE BASED ON VIM

Introducing the two auxiliary variables

$$q = u_t \text{ and } \sigma = u_x, \quad (2)$$

the equation (1) can be rewritten as the following first-order system

$$\begin{cases} (a) & q_t - \sigma_x + \mathfrak{N}u = f(x, t), \\ (b) & u_t - q = 0, \\ (c) & \sigma = u_x. \end{cases} \quad (3)$$

According to the variational iteration method, we can construct the following correction functional for equation (3a)

$$q_{n+1}(x, t) = q_n(x, t) + \int_0^t \lambda(\xi) \left[\frac{\partial q_n(x, \xi)}{\partial \xi} - \frac{\partial \tilde{\sigma}_n(x, \xi)}{\partial x} + \mathfrak{N}\tilde{u}_n(x, \xi) - f(x, \xi) \right] d\xi, \quad (4)$$

and the following two equalities

$$u_{n+1}(x, t) = \int_0^t q_{n+1}(x, \xi) d\xi + u_n(x, 0), \quad (5)$$

and

$$\sigma_{n+1}(x, t) = \frac{\partial u_{n+1}}{\partial x}(x, t). \quad (6)$$

Choosing the function $u_0(x, t)$ with functions $\sigma_0(x, t) = u_{0x}(x, t)$, $q_0(x, t) = u_{0t}(x, t)$, we can obtain the exact solution by

$$\begin{aligned} u(x, t) &= \lim_{n \rightarrow \infty} u_n(x, t), \\ q(x, t) &= \lim_{n \rightarrow \infty} q_n(x, t), \\ \sigma(x, t) &= \lim_{n \rightarrow \infty} \sigma_n(x, t). \end{aligned} \quad (7)$$

III. NUMERICAL EXAMPLE

In this section, we will provide some examples to illustrate the effectiveness of our method.

Example 1: Use the new procedure to solve the second hyperbolic equation with initial and boundary condition

$$\begin{cases} u_{tt} - u_{xx} = 0, 0 < x < \pi, t > 0, \\ u(0, t) = 0, u(\pi, t) = 0, \\ u(x, 0) = 0, u_t(x, 0) = \sin x. \end{cases} \quad (8)$$

From (4)-(6), we can obtain $\lambda = -1$. With the given initial values, we can choose $u_0(x, t) = t \sin x, q_0(x, t) = \sin x, \sigma_0(x, t) = t \cos x$. Using (4)-(6), we can obtain the following successive approximations

$$\begin{aligned} u_0(x, t) &= t \sin x, \\ q_0(x, t) &= \sin x, \\ \sigma_0(x, t) &= t \cos x, \\ q_1(x, t) &= \sin x - \frac{1}{2}t^2 \sin x, \\ u_1(x, t) &= t \sin x - \frac{1}{3!}t^3 \sin x, \\ \sigma_1(x, t) &= t \cos x - \frac{1}{3!}t^3 \cos x, \\ q_2(x, t) &= \sin x - \frac{1}{2}t^2 \sin x + \frac{1}{24}t^4 \sin x, \\ u_2(x, t) &= t \sin x - \frac{1}{3!}t^3 \sin x + \frac{1}{5!}t^5 \sin x, \\ \sigma_2(x, t) &= t \cos x - \frac{1}{3!}t^3 \cos x + \frac{1}{5!}t^5 \cos x, \\ &\dots\dots\dots \\ q_n(x, t) &= \sin x \left(1 - \frac{1}{2!}t^2 + \frac{1}{4!}t^4 - \frac{1}{6!}t^6 + \dots \right), \\ u_n(x, t) &= \sin x \left(t - \frac{1}{3!}t^3 + \frac{1}{5!}t^5 - \frac{1}{7!}t^7 + \dots \right), \\ \sigma_n(x, t) &= \cos x \left(t - \frac{1}{3!}t^3 + \frac{1}{5!}t^5 - \frac{1}{7!}t^7 + \dots \right). \end{aligned} \quad (9)$$

Use Taylor series for $\sin t$ and $\cos t$ and (7) to obtain the exact solution

$$\begin{aligned} q(x, t) &= \sin x \cos t, \\ u(x, t) &= \sin x \sin t, \\ \sigma(x, t) &= \cos x \sin t. \end{aligned} \quad (10)$$

In Table I and Figs. 1-6, we compare the new procedure solution $u_1(x, t), q_1(x, t), \sigma_1(x, t)$ with the exact solution $u(x, t), q(x, t), \sigma(x, t)$, respectively. It is easy to see that our method is effective.

Example 2: Use the new procedure to solve the linear inhomogeneous Klein-Gordon equation([20],P373) with initial condition

$$\begin{cases} u_{tt} - u_{xx} + u = 2 \sin x, \\ u(x, 0) = \sin x, u_t(x, 0) = 1. \end{cases} \quad (11)$$

From (4)-(6), we can obtain $\lambda = -1$. With the given initial values, we can choose $u_0(x, t) = t + \sin x, q_0(x, t) = 1, \sigma_0(x, t) = \cos x$. Using (4)-(6), we can obtain the following successive approximations

$$\begin{aligned} u_0(x, t) &= t + \sin x, \\ q_0(x, t) &= 1, \\ \sigma_0(x, t) &= \cos x, \\ q_1(x, t) &= 1 - \frac{t^2}{2}, \\ u_1(x, t) &= t + \sin x - \frac{1}{3!}t^3, \\ \sigma_1(x, t) &= \cos x, \\ q_2(x, t) &= 1 - \frac{t^2}{2!} + \frac{t^4}{4!}, \\ u_2(x, t) &= t + \sin x - \frac{1}{3!}t^3 + \frac{1}{5!}t^5, \\ \sigma_2(x, t) &= \cos x, \\ &\dots\dots\dots \\ q_n(x, t) &= 1 - \frac{1}{2!}t^2 + \frac{1}{4!}t^4 - \frac{1}{6!}t^6 + \dots, \\ u_n(x, t) &= \sin x + \left(t - \frac{1}{3!}t^3 + \frac{1}{5!}t^5 - \frac{1}{7!}t^7 + \dots \right), \\ \sigma_n(x, t) &= \cos x. \end{aligned} \quad (12)$$

Using Taylor series for $\sin t$ and $\cos t$ and (7), we obtain the exact solution

$$\begin{aligned} q(x, t) &= \cos t, \\ u(x, t) &= \sin x + \sin t, \\ \sigma(x, t) &= \cos x. \end{aligned} \quad (13)$$

Example 3: Use the new procedure to solve the nonlinear inhomogeneous Klein-Gordon equation([20],P380) with initial condition

$$\begin{cases} u_{tt} - u_{xx} - u + u^2 = xt + x^2t^2, \\ u(x, 0) = 1, u_t(x, 0) = x. \end{cases} \quad (14)$$

From (4)-(6), we can obtain $\lambda = -1$. With the given initial values, we can choose $u_0(x, t) = 1 + xt, q_0(x, t) = x, \sigma_0(x, t) = t$. Using (4)-(6), we can obtain the following successive approximations

$$\begin{aligned} u_0(x, t) &= 1 + tx, \\ q_0(x, t) &= x, \\ \sigma_0(x, t) &= t, \\ q_1(x, t) &= x, \\ u_1(x, t) &= 1 + tx, \\ \sigma_1(x, t) &= t. \end{aligned} \quad (15)$$

From (15), we know that the exact solution

$$\begin{aligned} u(x, t) &= 1 + tx, \\ q(x, t) &= x, \\ \sigma(x, t) &= t. \end{aligned} \quad (16)$$

TABLE I
 COMPARISON BETWEEN THE EXACT SOLUTION WITH VIM
 SOLUTION $\{u_1(x, t), q_1(x, t), \sigma_1(x, t)\}$.

x	t	$u(x, t)$	$q(x, t)$	$\sigma(x, t)$
$\frac{\pi}{6}$	0.2	0.099335	0.490033	0.172053
$\frac{\pi}{6}$	0.4	0.337246	0.797662	0.194709
$\frac{2\pi}{3}$	0.6	0.488995	0.714762	-0.282321
$\frac{5\pi}{6}$	0.8	0.358678	0.348353	-0.621249
x	t	$u_1(x, t)$	$q_1(x, t)$	$\sigma_1(x, t)$
$\frac{\pi}{6}$	0.2	0.099333	0.49	0.17205
$\frac{\pi}{6}$	0.4	0.337173	0.796743	0.194667
$\frac{2\pi}{3}$	0.6	0.488438	0.710141	-0.282
$\frac{5\pi}{6}$	0.8	0.357333	0.34	-0.618919

IV. CONCLUDING REMARKS

In this article, we propose a new approximate procedure based on He's Variational iteration method for second-order hyperbolic wave equations. We split the hyperbolic wave equation (1) into a first-order system (3) of equations by introducing two transformations $q = u_t$ and $\sigma = u_x$ and formulate a new iteration system (4)-(6). Our procedure can obtain the approximation solution for the scalar unknown u , time derivative $q = u_t$ and space derivative $\sigma = u_x$, simulta-

neously. We choose some examples to show the effectiveness of our method.

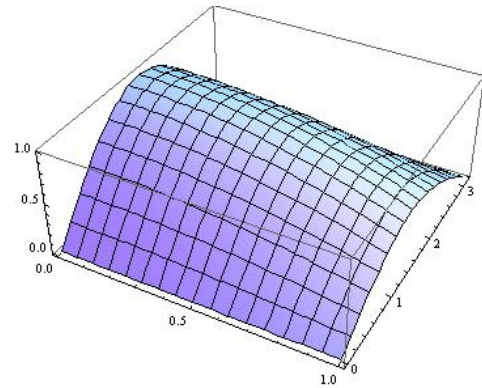

Fig. 3. The surface of $q_1(x, t)$

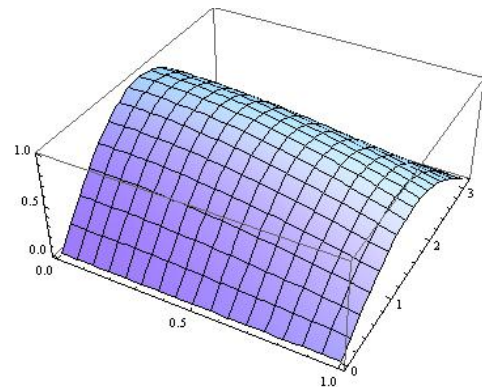

Fig. 4. The surface of $q(x, t)$

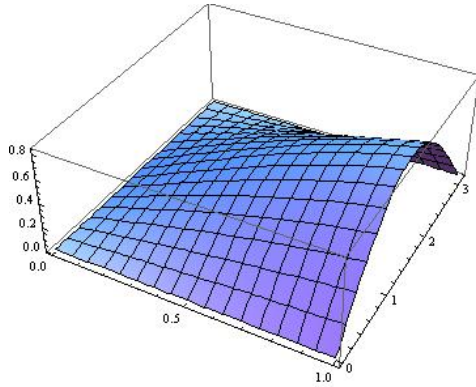

Fig. 1. The surface of $u_1(x, t)$

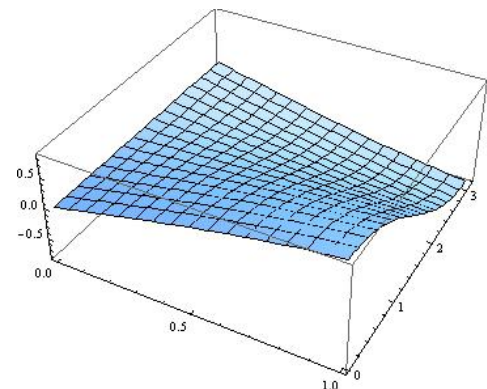

Fig. 5. The surface of $\sigma_1(x, t)$

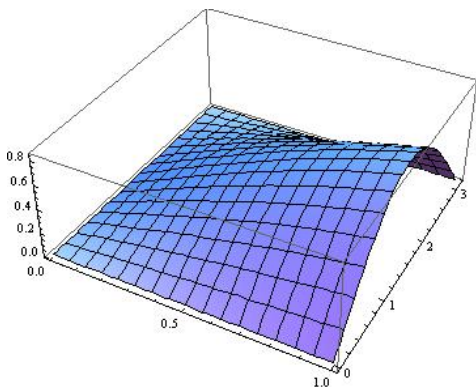

Fig. 2. The surface of $u(x, t)$

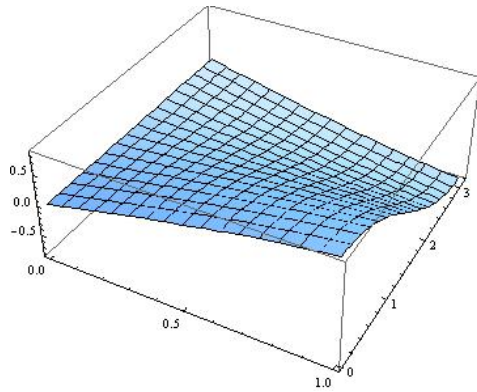

Fig. 6. The surface of $\sigma(x, t)$

ACKNOWLEDGMENT

This work is supported by National Natural Science Fund (11061021), the Scientific Research Projection of Higher Schools of Inner Mongolia (NJZZ12011; NJ10006; NJZY13199), the Natural Science Fund of Inner Mongolia Autonomous Region (2012MS0108; 2012MS0106), the Program of Higher-level talents of Inner Mongolia University (125119) and the Scientific Research Projection of Inner Mongolia University of Finance and Economics (KY1101)

REFERENCES

- [1] Y.R. Yuan, H. Wang, Error estimates for the finite element methods of nonlinear hyperbolic equations, *J. Systems Sci. Math. Sci.*, 5 (3) (1985) 161-171.
- [2] S. Larsson, V. Thome, L.B. Wahlbin, Finite element methods for a strongly damped wave equation, *IMA J. Numer. Anal.* 11 (1991) 115-142.
- [3] D.Y. Shi, B.Y. Zhang, High accuracy analysis of the finite element method for nonlinear viscoelastic wave equations with nonlinear boundary conditions, *J Syst. Sci. Complex.* 24 (2011) 795-802.
- [4] Y. Liu, J.F. Wang, H. Li, W. Gao, S. He, A new splitting H^1 -Galerkin mixed method for pseudo-hyperbolic equations, *Internat. J. Eng. Natur. Sci.* 5 (2) (2011) 58-63.
- [5] Y. Liu, H. Li, J.F. Wang, S. He, Splitting positive definite mixed element methods for pseudo-hyperbolic equations, *Numer. Methods Partial Differential Eq.* 28 (2) (2012) 670-688.
- [6] Y. Liu, H. Li, H^1 -Galerkin mixed finite element methods for pseudo-hyperbolic equations, *Appl. Math. Comput.* 212 (2009) 446-457.
- [7] L.C. Cowsar, T.F. Dupont, M.F. Wheeler, A priori estimates for mixed finite element approximations of second-order hyperbolic equations with absorbing boundary conditions. *SIAM J. Numer. Anal.* 33 (1996) 492-504.
- [8] J. S. Zhang, D.P. Yang, A splitting positive definite mixed element method for second-order hyperbolic equations, *Numer. Methods Partial Differential Eq.* 25 (2009) 622-636.
- [9] H. Guo, H.X. Rui, Least-squares Galerkin procedures for pseudo-hyperbolic equations, *Appl. Math. Comput.* 189 (2007), 425-439.
- [10] A.K. Pani, J.Y. Yuan, Mixed finite element method for a strongly damped wave equation, *Numer. Methods Partial Differential Eq.* 17 (2011) 105-119.
- [11] Y.P. Chen, Y.Q. Huang, The superconvergence of mixed finite element methods for nonlinear hyperbolic equations, *Commun. Nonlinear Sci. Numer. Simul.* 3 (1998) 155-158.
- [12] Z.D. Luo, H. Li, Y.J. Zhou, X.M. Huang, A reduced FVE formulation based on POD method and error analysis for two-dimensional viscoelastic problem, *J. Math. Anal. Appl.* 385 (1) (2012) 310-321.
- [13] D.H. Shou, J.H. He, Beyond Adomian method: The variational iteration method for solving heat-like and wave-like equations with variable coefficients, *Phys. Lett. A.* 372 (3) (2008) 233-237.
- [14] E. Yusufoglu, A. Bekir, Application of the variational iteration method to the regularized long wave equation, *Comput. Math. Appl.* 54 (2007) 1154-1161.
- [15] J. Biazar, H. Ghazvini, An analytical approximation to the solution of a wave equation by a variational iteration method, *Appl. Math. Lett.* 21 (2008) 780-785.
- [16] B. Raftari, A. Yildirim, Analytical solution of second-order hyperbolic telegraph equation by variational iteration and homotopy perturbation methods, *Results. Math.* 61 (2012) 13-28.
- [17] D.K. Salkuyeh, H.R. Ghehsareh, Convergence of the Variational Iteration Method for the Telegraph Equation with Integral Conditions, *Numer. Methods Partial Differential Eq.* 28(2) (2012): 670-688.
- [18] M. Dehghan, A. Saadatmandi, Variational iteration method for solving the wave equation subject to an integral conservation condition, *Chaos Solitons Fractals.* 41 (2009) 1448-1453.
- [19] A.M. Wazwaz, The variational iteration method: A reliable analytic tool for solving linear and nonlinear wave equations, *Comput. Math. Appl.* 54 (7-8) (2007) 926-932.
- [20] Abdul-Majid Wazwaz, *Partial Differential Equations and Solitary Waves Theory*, Higher Education Press, Beijing, 2009.
- [21] R. Rajaram, M. Najafi, Analytical treatment and convergence of the Adomian decomposition method for a system of coupled damped wave equations, *Appl. Math. Comput.* 212 (1) (2009) 72-81.
- [22] J.H. He, A new approach to nonlinear partial differential equations, *Commun. Nonlinear Sci. Numer. Simul.* 2 (4) (1997) 203-205.
- [23] J.H. He, Variational iteration method: some recent results and new interpretations, *J. Comput. Appl. Math.* 207 (1) (2007) 3-17.
- [24] J.H. He, Some asymptotic methods for strongly nonlinear equations, *Internat. J. Modern Phys. B* 20 (10) (2006) 1141-1199.
- [25] J.H. He, G.C. Wu, F. Austin, Variational iteration method which should be followed, *Nonlinear Sci. Lett. A.* 1 (2010), 1-30.
- [26] J.H. He, X.H. Wu, Construction of solitary solution and compacton-like solution by variational iteration method, *Chaos, Solitons Fractals.* 29 (2006) 108-113.
- [27] S.Q. Wang, J.H. He, Variational iteration method for solving integro-differential equations, *Phys. Lett. A.* 367 (2007) 188-191.
- [28] J.H. He, A variational iteration approach to nonlinear problems and its applications, *Mech. Appl.* 20 (1) (1998) 30-31.