

A Model of a Heat Radiation on a Mould Surface in the Car Industry

J. Mlýnek, R. Srb

Abstract—This article is focused on the calculation of heat radiation intensity and its optimization on an aluminum mould surface. The inside of the mould is sprinkled with a special powder and its outside is heated by infra heaters located above the mould surface, up to a temperature of 250°C. By this way artificial leathers in the car industry are produced (e. g. the artificial leather on a car dashboard). A mathematical model of heat radiation of infra heaters on a mould surface is described in this paper. This model allows us to calculate a heat-intensity radiation on the mould surface for the concrete location of infra heaters above the mould surface. It is necessary to ensure approximately the same heat intensity radiation on the mould surface by finding a suitable location for the infra heaters, and in this way the same material structure and color of artificial leather. In the model we have used a genetic algorithm to optimize the radiation intensity on the mould surface. Experimental measured values for the heat radiation intensity by a sensor in the surroundings of an infra heater are used for the calculation procedures. A computational procedure was programmed in language Matlab.

Keywords—Genetic algorithm, mathematical model of heat radiation, optimization of radiation intensity, software implementation

I. INTRODUCTION

THIS article is focused on a numerical calculation of heat radiation intensity on an aluminum mould surface. Moulds of different proportions with variously contoured surfaces and with weights of approximately 300 [kg] are used in the production of artificial leathers applied in the car interior in the automotive industry (e.g. the artificial leather on passenger car dashboards, see Fig. 1, the size of the mould is $1,5 \times 0,6 \times 0,5$ [m³]). The inside of the mould is sprinkled with a special powder and its outside is subsequently heated by infra heaters located above the mould at the distance of between 5 and 30[cm] from the mould surface to a temperature of 250[°C]. The infra heaters have a tubular form and their length is between 15 and 30[cm] (see Fig. 2). The heater is equipped with a mirror located above the radiating tube, which reflects heat radiation in the adjusted direction. For this reason we did not use the properties of point heat radiation. In our model we also do not know the heater distribution intensity function from the heater manufacturer. Experimental measured values

for the heat radiation intensity by a sensor in the surroundings on an infra heater and transformations of Cartesian coordinate systems in Euclidean space E_3 are used in the linear interpolation radiation intensity in individual points of the mould surface.

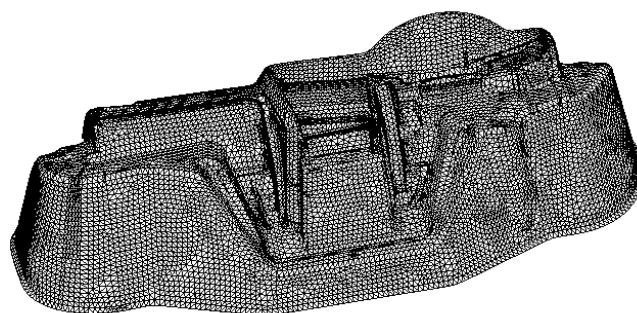

Fig. 1 Aluminum mould of passenger car dashboard

The mathematical model detailed in the following chapter allows us to calculate the heat radiation intensity on the whole mould surface for the concrete location of heaters. It is necessary to ensure approximately the same heat radiation intensity (within the given tolerance) on the mould surface, and in this way to assure the same material structure and color of the artificial leather. The setting of the location of the heaters in production is realized upon the base of the experiences of manufacturing technicians so far. However, this way of situating heaters and their installation on construction above the mould surface is very laborious and time-consuming (depending on the mould size, the heaters can number from 50 to 200).

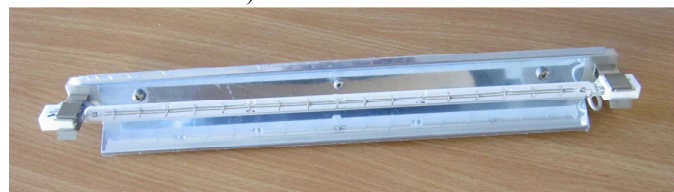

Fig. 2 Ushio infra heater with 2000 W capacity

In the following chapter the described model allows us to optimize the location of heaters. We must prevent possible collisions of heaters during the optimizing process of location of heaters. We keep track of the following three types of collisions: one heater does not radiate on a second heater more than the given limit, one heater has sufficient distance from second heater, a heater has sufficient distance from the mould surface and is over the surface. The optimization process is technically more difficult, and we therefore have chosen a genetic algorithm as the method to finding a solution.

J. Mlýnek is with the Department of Mathematics and Didactics of Mathematics, Faculty of Sciences, Humanities and Education, Technical University of Liberec, Czech Republic (phone +420-485-352-447, fax: +420-485-352-332; e-mail: jaroslav.mlynek@tul.cz).

R. Srb is with Institute of Mechatronics and Computer Engineering, Faculty of Mechatronics, Informatics and Interdisciplinary Studies, Technical University of Liberec, Czech Republic (phone +420-485-353-290, fax: +420-485-353-290; e-mail: radek.srb@tul.cz).

A model of a heat radiation intensity on a mould surface, the process of calculation of a heat radiation intensity on a mould surface for concrete location of heaters and a genetic algorithm to finding a suitable location for heaters will be described in more details in the following two chapters. The last chapter contains a solution of a practical example.

II. MODEL OF HEAT RADIATION ON THE MOULD SURFACE BY INFRA HEATERS

We will describe a heat radiation model in this chapter. The heaters and mould are represented in a 3-dimensional Euclidean space E_3 with a Cartesian coordinate system (O, e_1, e_2, e_3) , where vector $e_1 = (1, 0, 0)$, $e_2 = (0, 1, 0)$ and $e_3 = (0, 0, 1)$. This system we will mark (O, x_1, x_2, x_3) in the following text too.

A. Description of the mould surface

The mould surface is defined by the elementary surfaces p_j , where $1 \leq j \leq N$. It is true $\bigcup_{1 \leq j \leq N} p_j = P$, where P denotes the total mould surface and $\text{int } p_i \cap \text{int } p_j = \emptyset$ for $i \neq j$, $1 \leq i, j \leq N$. Every elementary surface is described by the following parameters: 1/ the centre gravity $T_j = (x_1^{Tj}, x_2^{Tj}, x_3^{Tj})$ 2/ the outer normal vector $v_j = (x_1^{vj}, x_2^{vj}, x_3^{vj})$ in point T_j , 3/ the area of elementary surface s_j [m^2]. We suppose a unit length of the outer normal vector v_j . It is then possible to unambiguously enter vector v_j through coordinates x_1^{vj}, x_2^{vj} (we suppose the outer normal vector does not direct "down").

Every elementary surface p_j is defined so by 6 parameters:

$$p_j: \left(x_1^{Tj}, x_2^{Tj}, x_3^{Tj}, x_1^{vj}, x_2^{vj}, s_j \right), \quad 1 \leq j \leq N. \quad (1)$$

B. Description of the heaters

We assume that all heaters have the same capacity and are of the same type. Every heater is represented by abscissa d [m] in length. The location of a heater (see Fig. 3) is defined by the following parameters: 1/ coordinates of the heater centre $S = [x_1^S, x_2^S, x_3^S]$, 2/ radiation direction vector $u = (x_1^u, x_2^u, x_3^u)$, we assume unit length of vector u and that component x_3^u is negative (i.e. the heater radiates "down"), then the coordinate x_3^u of vector u is explicitly allocated, 3/ the vector of the heater axis $r = (x_1^r, x_2^r, x_3^r)$, the coordinate x_3^r is explicitly allocated because the vectors u and r are orthogonal. The vector r is defined also by the angle φ that contains the vertical projection of vector r to a plane given by the axes x_1 and x_2 (ground plane) and the positive part of

axis x_1 ($0 \leq \varphi < \pi$). The unambiguous transformation exists between these two allocations. We will use the second expression that we need the smallest possible number of parameters to definition of heater location in the genetic algorithm.

Thus the location of every heater Z is described by the following 6 parameters:

$$Z: (x_1^S, x_2^S, x_3^S, x_1^u, x_2^u, \varphi). \quad (2)$$

The location of M heaters is described by $6M$ parameters.

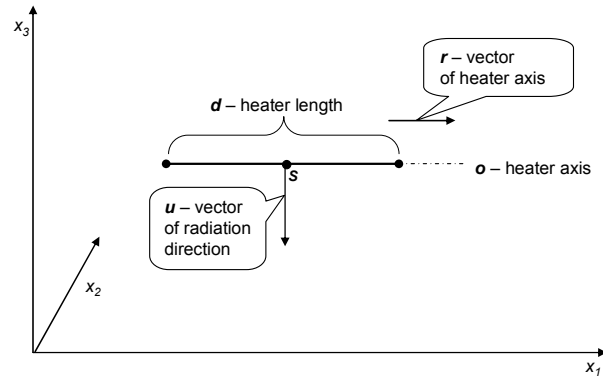

Fig. 3 Schematic representation of the heater

C. Experimental measurement and linear interpolation of radiation intensity

We took an experimental measurement of radiation intensity in surrounding of infra heater by sensor. We will assume the heater location Z defined by relation (2) is given by parameters $Z: (0, 0, 0, 0, 0, 0)$, i.e. the center S of a heater lies in the origin of a Cartesian coordinate system (O, x_1, x_2, x_3) , union radiation vector $u = (0, 0, -1)$ and vector of the heater axis $r = (1, 0, 0)$ in Cartesian coordinate system. Now we will describe the approach of radiation intensity calculation in a surroundings of heater Z .

The experimental measuring of radiation intensity in the vicinity of the heater was accomplished at the node points $a = [a_1, a_2, a_3, a_4, a_5]$ of the regular net in accordance with the setting of the elementary surface p_j given by the first five parameters in relation (1). We will assume point $b = [x_1^b, x_2^b, x_3^b, x_4^b, x_5^b]$ lies within the "hyperrectangle" net points determined by heater Z . We will use linear interpolation of a five variables function. We will assume that the point b holds $a_{j,i_j} \leq x_j^b \leq a_{j,i_j+1}$ for $1 \leq j \leq 5$. Let us

denote $m_j = \frac{x_j^b - a_{j,i_j}}{a_{j,i_j+1} - a_{j,i_j}}$ for $1 \leq j \leq 5$. Then it holds for

the interpolation value of radiation intensity $I(b)$ at the point b of heater Z

$$I(b) = I(x_1^b, x_2^b, x_3^b, x_4^b, x_5^b) = \quad (3)$$

$$= \sum_{k_1=i_1}^{i_1+1} \dots \sum_{k_5=i_5}^{i_5+1} \left(I(a_{1,k_1}, a_{2,k_2}, a_{3,k_3}, a_{4,k_4}, a_{5,k_5}) \prod_{l=1}^5 H(l, k_l - i_l) \right)$$

where $H(l, 0) = 1 - m_l$ and $H(l, 1) = m_l$ (more detail in [1]).

D. General case of a heater location

Now we will describe the radiation intensity calculation in heater surroundings in the case of general location of heater Z. In this case we accomplish the transformation of Cartesian coordinate system (O, e_1, e_2, e_3) to a positively oriented Cartesian coordinate system $(S, r, n, -u)$, where point S is the centre of heater Z, r is vector of the heater axis, vector $-u$ is opposite vector to vector u of radiation direction of a heater Z. The vector n is determined by the vector product of the vectors $-u$ and r (more details in [4]) and is defined by the relation

$$n = (-u) \times r = \begin{pmatrix} -\begin{vmatrix} x_2^u & x_3^u \\ x_2^r & x_3^r \end{vmatrix} & \begin{vmatrix} x_1^u & x_3^u \\ x_1^r & x_3^r \end{vmatrix} & -\begin{vmatrix} x_1^u & x_2^u \\ x_1^r & x_2^r \end{vmatrix} \end{pmatrix}. \quad (4)$$

We suppose unit lengths of the vectors r , n and $-u$. We define orthonormal matrix \mathbf{A} (i.e. $\mathbf{A}^T \mathbf{A} = \mathbf{E}$ where \mathbf{E} denotes unit matrix):

$$\mathbf{A} = \begin{pmatrix} x_1^r & x_1^n & -x_1^u \\ x_2^r & x_2^n & -x_2^u \\ x_3^r & x_3^n & -x_3^u \end{pmatrix}. \quad (5)$$

We denote $T_j' = [x_1^{T_j'}, x_2^{T_j'}, x_3^{T_j'}]$ the transformation of the centre gravity $T_j = [x_1^{T_j}, x_2^{T_j}, x_3^{T_j}]$ of elementary surface p_j in a Cartesian coordinate system $(S, r, n, -u)$ where a point $S = [x_1^S, x_2^S, x_3^S]$ is the centre of the heater. We suppose coordinates of the points T_j, T_j', S are represented by the vectors $\mathbf{T}_j, \mathbf{T}_j', \mathbf{S}$. Then the transformation of the point T_j is given by relation

$$(\mathbf{T}_j')^T = \mathbf{A}^T (\mathbf{T}_j - \mathbf{S})^T. \quad (6)$$

Similarly, a transformation of the outer normal v_j in centre gravity T_j of elementary surface p_j is determined by relation

$$(\mathbf{V}_j')^T = \mathbf{A}^T \mathbf{V}_j. \quad (7)$$

On base transformations (6) and (7) we convert case-general heater location to the case described in paragraph C of this chapter. Now we know to calculate heat radiation intensity of heater on gravity centre T_j of any elementary surface p_j .

E. Calculation of total radiation intensity on mould surface

In this paragraph we will describe a procedure for calculation of radiation intensity on an elementary mould surface for a given location of heaters. The parameters of the all elementary surfaces are defined. We denote L_j set for all

the heaters radiating on j -th elementary surface for the defined location of heaters, $1 \leq j \leq N$. Furthermore, we will denote I_{jl} [W/m^2] radiation intensity of l -th heater on the j -th elementary surface. The total radiation intensity I_j on the j -th elementary surface is defined (more details in [5])

$$I_j = \sum_{l \in L_j} I_{jl}. \quad (8)$$

We denote I_{opt} recommended radiation intensity on the mould surface by producer. We determine the difference F_j of the radiation intensity on j -th elementary surface I_j ($1 \leq j \leq N$) from recommended radiation intensity I_{opt} upon the basis of the relation

$$F_j = |I_j - I_{opt}|. \quad (9)$$

The average difference of radiation intensity F is given by the relation

$$F = \frac{\sum_{j=1}^N F_j s_j}{\sum_{j=1}^N s_j}. \quad (10)$$

We highlight that s_j denotes the area of the elementary surface p_j .

III. THE USE OF A GENETIC ALGORITHM TO OPTIMIZE THE LOCATION OF THE HEATERS

In this chapter we will describe a procedure of optimization of location of heaters. We do not know the analytical expression of radiation intensity in the surroundings of a heater from a producer. During optimization we must test three possible collisions of heaters: one heater does not radiate on a second heater more than the given limit, one heater has sufficient distance from the second heater, a heater has sufficient distance from mould surface and is over the surface. Hence, optimization is a more complicated process. We have chosen a genetic algorithm to optimize the location of the heaters. We note that the terms and relations used in this chapter in connection with the genetic algorithm are described and explained in more detail e.g. in [2] and [3].

The location of every heater is defined by 6 real parameters according to relation (2). We suppose that M heaters are used for the heat radiation of a mould surface. Then $6M$ parameters are necessary to the definition of location of all heaters. In our problem one chromosome will represent one individual i.e. one possible location of heaters and particular genes of the chromosome will represent determining parameters of location of heaters. A population contains Q individuals. Sequentially randomly generated individuals are saved in the matrix $\mathbf{B}_{Q \times 6M}$. Every row of matrix \mathbf{B} represents one individual. Our goal is to find such individual y that radiation intensity

on the mould surface approaches the value I_{opt} recommended by the producer. Hence, we seek individual $y_{min} \in B$ satisfactory condition

$$F(y_{min}) = \min_{y \in B} F(y), \quad (11)$$

where $B \subset E_{6M}$ (the Euclidean space of dimension $6M$) is searched space and function F is defined by relation (10).

A. Schematic description of a used genetic algorithm

In this paragraph we will describe schematically *partial steps* of a used *genetic algorithm*:

1/ the creation of an initial individual (specimen) and an initial population of individuals,

2/ the evaluation (fitness) of the all individuals given by relation (10) and the execution of sorting of all individuals according their evaluation F ,

3/ *while* a condition of termination isn't fulfilled *do*

if operation crossover is randomly chosen *then*

randomly select a pair of parents,

execute of operation crossover

else

randomly select an individual,

execute of operation mutation

end if,

integration of new calculated individuals and their

evaluation (fitness),

sorting of all individuals in accordance

with evaluations,

storage only first Q individuals with the best

evaluation in matrix \mathbf{B} for subsequent calculation

end while,

4/ output of the first row of matrix \mathbf{B} - the best individual found.

B. More detailed description of some parts of a genetic algorithm

The setting of *initial individual* (specimen) is chosen in a such a way that all the centres of heaters create nodes in a regular rectangular network and lie over the mould, in a parallel plane with the plane determined by axes x_1 and x_2 .

The vector of the heater axis is parallel with axis x_1 (angle $\varphi = 0$ in relation (2)) for all heaters. We generate consequently $Q-1$ individuals by random modifications of gene values of initial individual and we get initial generation of individuals.

The following operations and functions are used in the genetic algorithm described in paragraph A.

Evaluation function (fitness) F for the individuals y is defined by relation (10).

Individual selection to operation crossover or to operation mutation is implemented on the principle *fitness-proportionate selection*. Let us consider a population with Q individuals (i.e. y_1, y_2, \dots, y_Q). We specify

$$G = \sum_{j=1}^Q \frac{1}{F(y_j)}, \quad (12)$$

we suppose $F(y_j) \neq 0$ (i.e. we suppose that for no individual is the radiation intensity wholly uniform across the whole mould surface and equal to I_{opt}). The probability p_j of selection of individual y_j is defined by relation

$$p(y_j) = \frac{1}{F(y_j) \cdot G}. \quad (13)$$

We generate a random number $r \in (0, 1)$ in every selection of an individual from the population. We will select an individual y_i if and only if the following holds true

$$\sum_{j=1}^{i-1} p(y_j) < r \leq \sum_{j=1}^i p(y_j) \text{ for } i = 1, 2, \dots, Q, \quad (14)$$

where we put $\sum_{j=1}^{i-1} p(y_j) = 0$ for $i = 1$. During *operation*

crossover we do only *one point crossover* and modify variants of the crossover. During *operation mutation* we change randomly just one gene of the individual. We mention that all genes of individual are real numbers.

IV. PRACTICAL EXAMPLE

The mentioned process of radiation intensity and the calculation of the radiation-intensity optimization on a mould surface was programmed in Matlab language. In this last chapter we will apply this program to a solution to a practical example.

The calculation was accomplished for an aluminum mould to produce a part of artificial leather on a passenger car dashboard. A mould is displayed in Fig. 4.

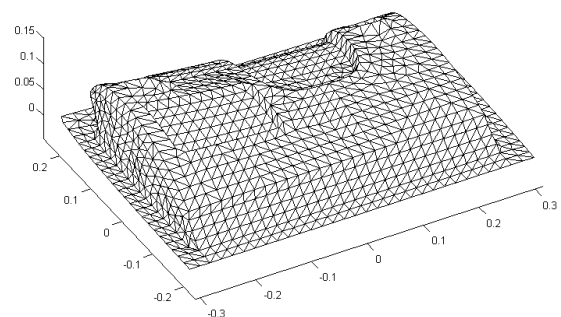

Fig. 4 Aluminum mould

Its size is $0,6 \times 0,4 \times 0,12$ [m³]. The surface of mould is defined by 2187 triangular elements p_j , for areas s_j of p_j it is true $19 \leq s_j \leq 406$ [mm²]. We will use 25 infra heaters to heat radiation on a mould surface.

All heaters are of the same type and have the following parameters: producer Philips, capacity 1600 [W], length 15[cm], width 4[cm]. The recommended radiation intensity I_{opt} on the mould surface by this producer is 50 [kW/m²].

We set the specimen in accordance with its construction described in paragraph B of chapter III. The parallel plane with axis x_1 and x_2 contains the centres of all the heaters and is in distance $g = 10$ [cm] over the maximum $x_{3,max}$ of values $x_3^{T_j}$ of all centres of gravity T_j of the triangular elements of mould. The location of heaters defined by relation (2) is expressed in the form $Z : (x_1^S, x_2^S, x_{3,max} + g, 0, 0, 0)$, i. e. the heaters radiate down and their vectors of the heater axis are parallel with axis x_1 .

The average difference of radiation intensity (defined by relation (10)) of specimen y_1 is $F(y_1) = 34,25$ [kW/m²]. The location of the heaters of specimen y_1 and heat radiation intensities on elementary surfaces of mould are graphically displayed in Fig. 5 (the lighter shade of grey color denoting a higher heat radiation intensity).

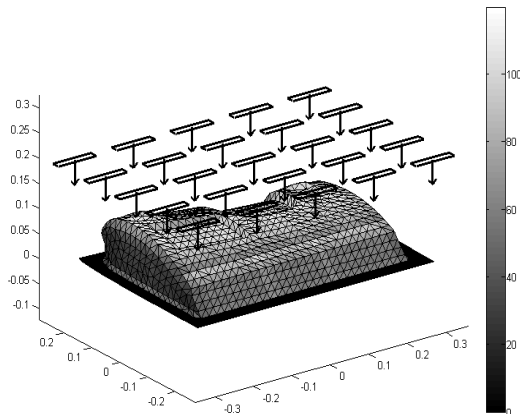

Fig. 5 The location of the heaters of specimen y_1 and heat radiation intensities on elementary surfaces of mould

Consequently we will construct an initial population of individuals by random parameters of modification of specimen. The population contains 30 individuals ($Q = 30$). Subsequently we will apply the genetic algorithm described in the previous chapter and we will obtain in every iteration new individuals. The finding of individual y_{min} defined by relation (11) isn't realistic in practice, but we are able to find optimized individual y_{opt} . The dependence size of value $F(y_{opt})$ on the number of genetic algorithm iterations is depicted graphically in Fig. 6. We finished calculation after 100 000 iterations of the genetic algorithm (we randomly generate two new individuals during every iteration) and for obtained y_{opt} the average difference of radiation intensity is

$F(y_{opt}) = 5,11$ [kW/m²]. The location of heaters of finding individual y_{opt} is stated in Table I. Every row of the table describes the location of one heater corresponding to relation (2).

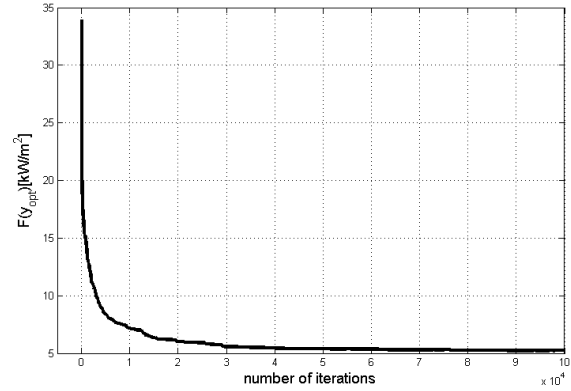

Fig. 6 Dependence of value $F(y_{opt})$ on iteration number

The graphical representation of heat radiation intensity on the mould surface (levels of radiation intensity correspond to shades of gray color) and location of heaters are illustrated in Fig. 7. Every heater is displayed by a "thin rectangle" (corresponding to the tubular form of the heater) and an arrow (corresponding to the radiation direction of the heater).

TABLE I
 LOCATION OF HEATERS OF OPTIMIZED INDIVIDUAL y_{opt}

1.	(-0.3026; -0.2146; 0.1616; 0.0123; 0.1604; 2.6007)
2.	(-0.1496; -0.2136; 0.1394; -0.2973; 0.0439; 0.4807)
3.	(0.0871; -0.2562; 0.2075; 0.0313; -0.0885; 3.1353)
4.	(0.1742; -0.2177; 0.1411; -0.2375; 0.0161; 0.2011)
5.	(0.3065; -0.1772; 0.1367; -0.0731; 0.0987; 2.1233)
6.	(-0.2561; -0.0351; 0.1483; -0.6147; 0.2935; 0.3689)
7.	(-0.1355; -0.1109; 0.2056; -0.0191; 0.0613; 1.9798)
8.	(0.0015; -0.1711; 0.1759; 0.0177; -0.3146; 2.0436)
9.	(0.1558; -0.1107; 0.2031; 0.0618; -0.2471; 1.4497)
10.	(0.3279; -0.0729; 0.1645; 0.3949; 0.0068; 0.4565)
11.	(-0.3145; -0.0339; 0.2063; -0.2741; 0.0133; 0.7836)
12.	(-0.1936; -0.0218; 0.2715; -0.6916; -0.2436; 2.6099)
13.	(-0.0156; -0.0282; 0.2045; 0.0302; -0.0202; 2.3369)
14.	(0.1495; 0.0220; 0.2189; 0.5844; -0.1022; 0.0000)
15.	(0.2979; 0.0058; 0.2048; 0.4125; 0.0298; 1.4386)
16.	(-0.2949; 0.0789; 0.2038; 0.3986; -0.0143; 3.1352)
17.	(-0.1679; 0.0816; 0.2119; 0.2592; 0.4182; 1.4712)
18.	(0.0083; 0.1253; 0.1990; 0.2547; 0.1533; 2.9160)
19.	(0.1529; 0.1436; 0.2065; -0.1176; 0.0523; 3.1267)
20.	(0.2909; 0.1439; 0.2082; -0.0635; 0.3502; 1.2644)
21.	(-0.2046; 0.1728; 0.1420; -0.0027; 0.0041; 1.8309)
22.	(-0.1644; 0.2228; 0.2048; 0.0058; 0.2559; 1.9350)
23.	(-0.0023; 0.2316; 0.1698; 0.0037; 0.2071; 1.8901)
24.	(0.1171; 0.2076; 0.1116; 0.0440; 0.1349; 2.8693)
25.	(0.2977; 0.1521; 0.1343; -0.1150; -0.0505; 1.1156)

Our goal is to achieve such location of heaters over the mould surface that approximately uniform heat radiation intensity is obtained on the whole mould surface. This way the approximately uniform temperature of mould surface is ensured and thus the same material structure and color of artificial leather on its whole surface. We note that small

differences in heat radiation intensity on the mould surface are acceptable since the temperature on the mould surface is continuously balanced by the heat conductivity of the mould material (in production are used aluminum and nickel moulds).

Our example is only illustrative, it is necessary to use a greater number of heaters and in this way to achieve a more uniform radiation intensity on the mould surface.

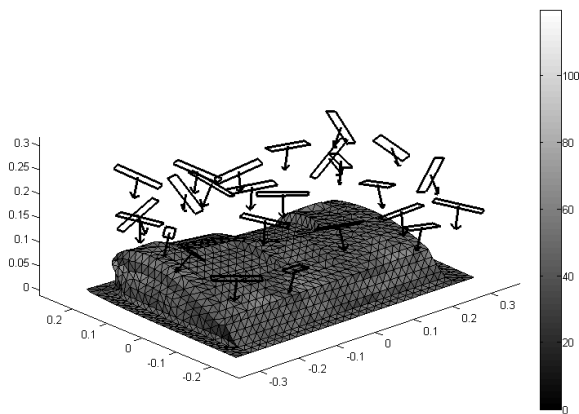

Fig. 7 Illustrate displaying of radiation intensity on mould surface and location of heaters of individual y_{opt} .

ACKNOWLEDGMENT

This research and processing of the article were supported by MPO project No. FR-TI1/266.

REFERENCES

- [1] H. M. Antia, *Numerical Methods for Scientists and Engineers*. Birkhäuser Verlag, Berlin, 2002, ch. 4.
- [2] M. Affenzeller, S. Winkler, S. Wagner, A. Beham, *Genetic Algorithms and Genetic Programming*. Chapman & Hall/CRC, Taylor & Francis Group, Boca Raton, 2009, ch.1 -2.
- [3] C. R. Reeves, J. E. Rowe, *Genetic Algorithms: Principles and Perspectives*. Kluwer Academic Publisher Group, AH Dordrecht, 2003, ch. 1-3.
- [4] B. Budinský, *Analytical and Differential Geometry*. SNTL, Prague, 1983, ch. 3, 6. (in Czech)
- [5] J. H. Linhard IV, J. H. Linhard V, *A Heat Transfer textbook*. <http://web.mit.edu/lienhard/www/ahtt.html>, 2011, ch. 4.