

Experimental Investigation of Surface Roughness Effect on Single Phase Fluid Flow and Heat Transfer in Micro-Tube

Mesbah. M. Salem, Mohamed. H. Elhsnawi, Saleh B. Mohamed

Abstract—An experimental investigation was conducted to study the effect of surface roughness on friction factor and heat transfer characteristics in single-phase fluid flow in a stainless steel micro-tube having diameter of 0.85mm and average internal surface roughness of 1.7 μ m with relative surface roughness of 0.002. Distilled water and R134a liquids were used as the working fluids and testing was conducted with Reynolds numbers ranging from 100 to 10,000 covering laminar, transition and turbulent flow conditions. The experiments were conducted with the micro-tube oriented horizontally with uniform heat fluxes applied at the test section. The results indicated that the friction factor of both water and R134a can be predicted by the Hagen-Poiseuille equation for laminar flow and the modified Miller correlation for turbulent flow and early transition from laminar to turbulent flows. The heat transfer results of water and R134a were in good agreement with the conventional theory in the laminar flow region and lower than the Adam's correlation for turbulent flow region which deviates from conventional theory.

Keywords—Pressure drop, heat transfer, distilled water, R134a, micro-tube, laminar and turbulent flow.

I. INTRODUCTION

IN recent years, interest in micro-fluidic systems has seen significant expansion due to the rapid growth in applications that deal with fluids at the micro-scale. Such applications include: micro-total analysis systems (μ -TAS) used for medical diagnostics, chemical and biological analysis, genetic analysis, drug screening [1], and in micro-cooling for high power electronic devices [2]. The understanding of fluid flow behavior in micro-channels is very important for the effective design of micro-fluidic devices [3]. Generally the classical Navier-Stokes equations, developed for conventional fluid flow are used to predict pressure drop and heat transfer in micro-channels. However, published experimental work for single phase laminar flow in micro-channels showed significant deviation from predictions [4]. Several justifications have been proposed in the literature to account for this deviation, like: surface roughness [5], variation of fluid properties [6] and viscous dissipation effects [7]. Surface roughness is a real feature in most micro-fluidic devices; it

takes many different shapes, depending on the micro-fabrication process, the material used and in some cases by adhesion of biological particles from the working liquids. With the increased surface to volume ratio in micro-channels, and surface roughness height being comparable with channel dimensions, the presence of surface roughness becomes more significant. Published experimental data has shown contradictory results with respect to the effect of surface roughness on friction factor and heat transfer characteristics.

II. LITERATURE OVERVIEW

Reference [8] carried out an experimental work to investigate the effect of surface roughness on heat transfer and pressure drop characteristics in micro-tubes. He found that by using different acid treatments, the surface roughness for commercial stainless tubes of 1.067mm and 0.62mm diameters were modified. He achieved relative surface roughness ranged from 0.00176 to 0.00281 for the larger diameter tube and from 0.00161 to 0.00355 for the smaller ones. His results for 1.067mm tube diameter showed that the effects of varying surface roughness on pressure drop are insignificant and the tube can be regarded as smooth. On the other hand, his results for 0.62mm tube diameter showed clear effects of the surface roughness values on pressure drop as the pressure drop increases with increasing the surface relative roughness. He concluded also that transition to turbulent regime was observed at Re number near 2300 for both tubes and for the smaller diameter tube, surface roughness had no effects on flow transition.

References [9] and [10] carried out series of extensive experiments using glass micro-tubes with diameters ranging from 50 to 247 μ m. Liquids with different polarities were used and Re number varied from 50 to 2500. He used Bulk flow measurements and micro-particle imaging velocimetry, μ PIV, and his results show that transition from laminar to turbulent flow occurred at Re number between 1800 and 2300 over the range of diameters used. While his results for the variation of Darcy friction factor versus measured Re number for the 50 μ m, 75 μ m and 100 μ m diameter micro-tubes indicated clearly the good agreement with the laminar conventional solution is evident.

Reference [11] studied frictional resistance for deionized water laminar flow through smooth and rough micro-tubes. He used glass, silicon and stainless steel micro-tubes with diameters ranged from 79.9 to 205.3 μ m. No surface roughness values were reported for the smooth glass and silicon micro-

Salem is with Department of Mechanical Engineering, Libya – University of Azzaytouna (Tel: +218 92 648 68 24; e-mail: elhsnawi@yahoo.com).

Elhsnawi is with Department of Mechanical Engineering, Libya – University of Azzaytouna (Tel: +218 92 648 48 79; e-mail: elhsnawi@gmail.com).

Saleh B. Mohamed is with Department of Mechanical Engineering, Libya – University of Azzaytouna (Tel: +218 92 644 36 84; e-mail: saleh_ba2004@yahoo.com).

tubes, whereas the stainless steel tubes came with a relative surface roughness, values of 0.03 to 0.04. His experimental results showed that for the smooth tubes, the Hagen-Poiseuille number, $f.Re$, remained very close to conventional value of 64, the value used for macro-tubes laminar flow analysis. As for the stainless steel micro-tubes, the Hagen-Poiseuille number was found to be 15-37% higher than 64, a finding that contradicts the conventional theory, which assumes that relative surface roughness below 0.05 has no effects on laminar flow characteristics.

Reference [12] measured pressure drop as a function of flow rate in micro-tubes for a variety of polar liquids with different ion concentrations. Working liquids were tap water, deionized water, a saline solution and a variety of glycerol-water mixtures. Stainless steel with maximum relative roughness of 0.024 and polyimide (smooth) micro-tubes were used, with diameters ranged from 120 to 440 μ m. Deviations from laminar Hagen-Poiseuille flow predictions of up to 17% were observed in the stainless steel tubes, but not in the smooth polyimide ones. Results showed that these deviations were independent from fluid viscosity and ion concentration changes, while surface roughness was the major cause for these deviations.

Reference [13] used smooth and roughened glass/fused silica micro-tubes to study the effect of wall surface roughness on the hydrodynamic behavior of adiabatic water flow through circular micro-channels. Internal diameters ranged from 31 μ m to 300 μ m for the smooth tubes and 126 μ m to 300 μ m for the roughened tubes. Internal surfaces were treated with a mixture of fine-grain abrasive powder and fluid silicon oil to give relative surface roughness < 1%. For the smooth micro-tubes, results indicated that the friction factor was in good agreement with the Hagen-Poiseuille theory for all diameters used and $Re > 300$. As for the roughened micro-tubes, their results showed that agreement with the conventional theory was achieved, apart from the 126 μ m diameter tube, where higher values of friction factor were observed. The authors attributed this deviation to the actual deformation of channel circularity, rather than surface roughness effect. Transition to turbulent regime was observed at Re number between 2000 and 3000.

Reference [14] investigated experimentally the pressure drop on rough stainless steel and smooth quartz- glass tubes of different diameter. They found that the results in the laminar regime agree well with theoretical values. However, early transition at Reynolds numbers ranging from 1100 to 1500 (for smooth micro-tubes) was recorded. For rough micro-tubes laminar theory agrees only until Re equal 800 where similar early transition was observed. Their results highlight that the role of the surface roughness not only affects the flow characteristics but also breaks the velocity boundary layer and lead to higher Nusselt numbers.

Reference [15] investigated experimentally convective heat transfer in silicon micro-channel heat sinks with water as coolant. The hydraulic diameter was from 299-491 μ m. His results showed that the measured values of the average Nusselt number were larger than those predicted by the conventional correlations.

Reference [16] investigated pressure drop and heat transfer coefficient of R-114 flowing in a 130 μ m micro-tube. The Reynolds number ranged from 100 to 8000 and the tube relative surface roughness was 0.0265. The results for Nusselt numbers were lower than those predicted by conventional correlations.

References [8] and [17] performed experiments of water in two tubes with different diameters ranging from 620 μ m to 1076 μ m. The measured local Nusselt number was in close agreement with the conventional theory, but for the small diameter tube 620 μ m, the higher relative roughness increased the Nusselt numbers. Thus it can be concluded that the wall roughness can play a more important role in micro-channels than that in macro-channels. They investigated also the performance of pressure drop and heat transfer of distilled water and R134a flowing inside 0.85mm inside diameter tube with surface relative roughness of 0.002.

III. EXPERIMENTAL APPARATUS

Fig. 1 shows a schematic diagram of the experimental facility used to measure the pressure drop and heat transfer characteristics of different fluids, namely, Distilled water and R134a. The test rig comprised a supply tank, circulating pump, flow measuring devices, micro- filter, calming section, test section and a subcooler. A high precision circulating pump of the type (Gear pump MCP-Z) was used to supply wide range of flow rates, (up to 833cm³/min). Upon exiting the pump, a portion of the flow passes through the main test circuit, while the remaining portion returned to the supply tank through a by-pass valve. After the pump the fluid was routed through the flow measuring device. Two flow meters of the float variable area (VA) type to measure the volume flow rate with an uncertainty of 1.25% FS (Full Scale). In order to avoid blockage of the micro-tube, a 7 μ m filter was placed between the outlet of the flow measuring device and the inlet of the test section. Before the test section, a calming section made from the same tube used in the test section was installed to enable the flow to become fully developed before entering the test section. A sub-cooler was installed after the test section to enable cooling the fluid to temperatures below its saturation temperature corresponding to the operating pressure. This ensured that the fluid remained in a liquid form and no evaporation occurred while heated in the test section.

Also, the test section was heated using a DC electrical power supply type TSX of (TTi, Thandar Instruments). The DC power was supplied through a fine electrically insulated wire wrapped uniformly and closely around the surface of the test section. The supplied voltage was measured by a Multi-meter (Fluke 336 meter) which has uncertainty of $\pm 2\%$, while the supplied current was measured by the power supply with uncertainty of $\pm 2\%$. The test rig was instrumented with thermocouples and pressure transducers to measure the inlet and outlet fluid temperatures, pressures and the surface temperature of the test section. Two T type copper – constantan thermocouple probes (OMEGA Engineering model TJC100-CPSS-M050-100) with 0.5mm diameter were used to measure the fluid temperatures at inlet and outlet from the test

section while three surface thermocouples of the type (5TC-TT-T-36-1M from OMEGA Engineering) with 0.1mm wire diameter were fixed in on the test section surface with high thermal conductivity glue. All the thermocouples were calibrated with respect to Platinum Resistance Transmitter (PRT100) and their uncertainty was found to be $\pm 0.2\%$. The pressure drop across the test section was measured using differential pressure transducer (Druck PDCR 4170, 0- 70 mbar) with $\pm 0.04\%$ FS uncertainty. The system pressure was measured by absolute pressure transducer (PDCR 4060, 0-15bar) with uncertainty of $\pm 0.15\%$. The test section was made of stainless steel tube with inner diameter 0.85mm and outer diameter 1.23mm, which was wrapped with a fiber wool thermal insulation to minimize heat losses. In the heat transfer experiments, the electrical power supplied at the test section were compared with the thermal energy absorbed by the fluid which runs only with energy balance of more than 95% were presented.

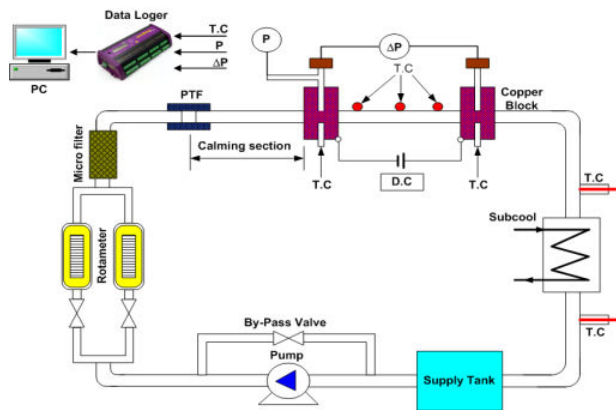

Fig. 1 Schematic diagram of the test facility

IV. DATA REDUCTION

The heat flux supplied was calculated as follows:

$$q'' = VI/A \quad (1)$$

A is the heat transfer area of the test section tube given by:

$$A = \pi d_i L_h \quad (2)$$

The average heat transfer coefficient was calculated using the total heat supplied total surface area of the test section and difference between the mean wall temperature and the mean fluid temperature as:

$$h = q'' / (T_{wi} - T_m) \quad (3)$$

where T_m is the mean fluid inlet and outlet temperatures. T_{wi} is the mean inner tube wall temperature obtained from the average outer tube wall temperature and calculated by averaging the surface thermocouples readings and the conduction resistance through the tube wall as:

$$T_{wi} = T_{wo} - q'' d_i \ln\left(\frac{d_o}{d_i}\right) / (2 * k_{wall}) \quad (4)$$

K_{wall} denotes the thermal conductivity of stainless steel and d_o is the outer diameter of the test micro-tube. The average Nusselt number was determined using:

$$N_u = hd_i / k_f \quad (5)$$

The Reynolds number was calculated from:

$$R_e = 4 \dot{m} / \pi \mu d_i \quad (6)$$

where, the fluid mass flow rate was calculated from the measured volume flow rate, the fluid density obtained at the average fluid bulk temperature, and μ is the fluid dynamic viscosity of the fluid obtained at the average fluid bulk temperature. The measured pressure drop between the inlet and outlet of the micro-channels was used to calculate the Darcy friction factor as:

$$f_D = 2 d_i \Delta P / \rho L u_m^2 \quad (7)$$

where L is the length of the test section. The mean velocity of the fluid inside the micro-tube (μm) was calculated by dividing the volume flow rate by the tube inner cross sectional area ($\pi d_i^2 / 4$).

V. MEASUREMENT OF SURFACE ROUGHNESS

Surface roughness measurement was conducted using Taylor Hobson Talysurf 120L unit. The instrument has a vertical resolution of 10nm. Fig. 2 shows a 2D display of the surface profile of a cut off piece of the tube with 0.85mm wide and 4mm while Fig. 3 shows a 3D display of the surface topology. Figs. 2 and 3 show that the surface roughness varies between $+2\mu m$ to $-2\mu m$, with mean value (ϵ) of $1.7\mu m$ which makes the relative roughness (ϵ/D_h where $D_h=d_i$) is equal to 0.002. Fig. 4 shows a scanning electron micro-scope (SEM) image of the cross section of the micro-tubes. The inner diameter of the micro-tube based SEM measurement is $847\mu m \pm 2\mu m$.

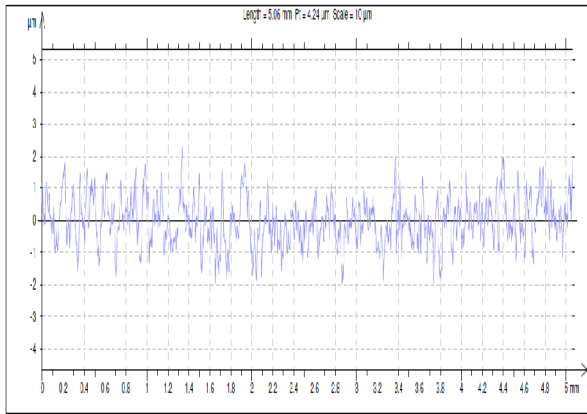

Fig. 2 Inner wall surface profile of the test micro-tube

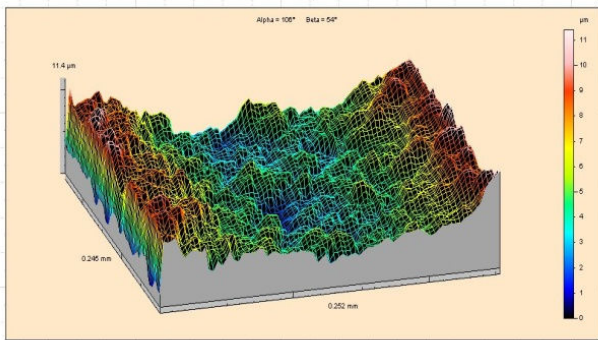

Fig. 3 3-D measurements for surface roughness

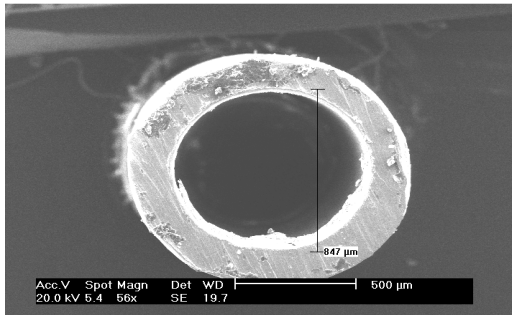

Fig. 4 SEM image of tested micro-tube

VI. RESULTS AND DISCUSSION

Fig. 5 shows the variation of Darcy friction factor with Reynolds number for distilled water. It can be seen that in low Reynolds number laminar regime, the friction factor agrees with the Hagen-Poiseuille theory ($f_D = 64/R_e$) up to Reynolds number of 1100 and deviates after that with an early transition to turbulent regime at Re of around 1100. In the turbulent regime, a good agreement with the modified Miller correlation recommended by Kandlikar et al. [18] was found. Fig. 6 illustrates the friction factor versus Reynolds number for R134a. It can be concluded that the experimental results in the laminar regime agree with the conventional theory. Early transition from laminar to turbulent flow was observed at Re_c of 1100. In fully developed turbulent flow, the test results are in close agreement with the modified Miller correlation.

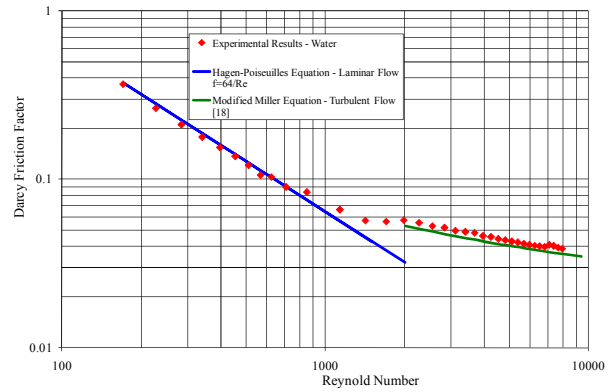

Fig. 5 Darcy friction factor variation with Reynolds number for distilled water

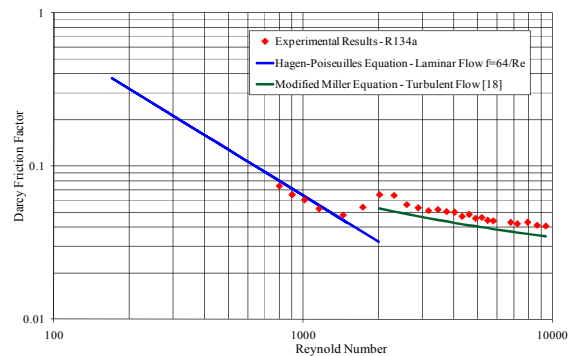

Fig. 6 Darcy friction factor variation with Reynolds number for R134a

Fig. 7 shows the Nusselt number versus the Reynolds number for distilled water. In the laminar flow (low Reynolds numbers) regime, the measured Nusselt numbers are slightly higher than the theoretical values for constant heat flux ($Nu = 4.36$) due to the surface roughness effect and as concluded by [18]. In the fully developed turbulent flow, the measured Nusselt numbers were compared with the correlation found originally in [19]. A procedure was also recommended by [18]. The experimental results are then found lower than those predicted by Adam's correlation.

Fig. 7 shows also the experimental results of the heat transfer performance of water in stainless steel micro-tubes with diameter of 0.765mm and surface relative roughness of 0.014 [20]. A good agreement between the current experimental results and those of [20] can be seen particularly in the turbulent flow region. Fig. 8 shows the variation of measured Nusselt number with Reynolds numbers for R134a and highlights that the measured Nusselt numbers are slightly lower than the theoretical constant heat flux value of 4.36 in the laminar flow regime. In the turbulent regime, the experimental results are lower than those predicted by [19] correlation.

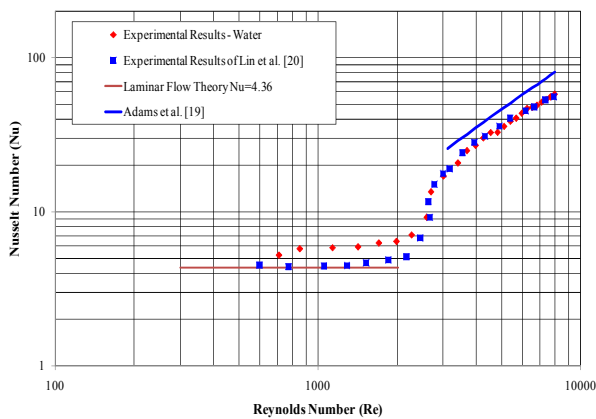

Fig. 7 Variation of the measured Nusselt number (Nu) with Reynolds number (Re) for distilled water

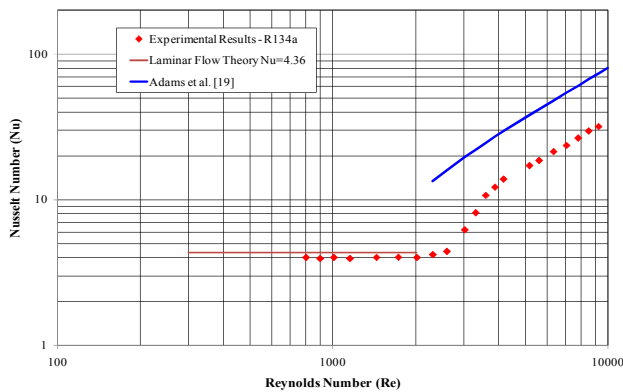

Fig. 8 Variation of the measured Nusselt number (Nu) with Reynolds number (Re) for R134a

VII. CONCLUSION

With recent advances in micro-fluidic devices, the understanding of fluid flow behavior in micro-channels is very important for the effective design of these devices. Published experimental data shows mixed results regarding conforming or deviation from conventional theory in terms of friction factor and Nusselt number. This work experimentally investigated the pressure drop and heat transfer performance of distilled water and R134a in a stainless steel micro-tube with 0.85mm inside diameter and 0.002 surface relative roughnesses. Results have shown good agreement with the conventional theory in the laminar region for both friction factor and Nusselt number. Although, early transition has been observed at Re_c of 1100, contradicts the conventional theory of Re_c 2300. Regarding the turbulent region, the friction factor results were close to those predicted by the modified miller correlation that takes into account the effect of surface roughness on friction factor while the heat transfer results showed that the measured Nusselt numbers are lower than those predicted. This experienced mixed behavior is similar to those found in the published literature which can be attributed to the surface roughness.

REFERENCES

- [1] Velten, T., Heinrich Ruf, H., Barrow, D., Aspragathos, N., Lazarou, P., Jung, E., Khan, C., Richter, M., Kruckow, J., & Wackerle, M. (2005). Packaging of Bio-MEMS: Strategies Technologies, and Applications. *IEEE Trans. Adv. Packag.* 28(4): 533-546.
- [2] Mudawar, I. (2000). Assessment of high -heat-flux thermal management schemes. *Proceedings of the Seventh Intersociety Conference on Thermal and Thermomechanical Phenomena in Electronic Systems.*
- [3] Morini, G.L. (2004). Laminar Liquid Flow Through Silicon Microchannels. *J. Fluids Eng., Transactions of the ASME.* 126(3): 485-489.
- [4] Morini, G.L. (2004). Single-phase Convective Heat Transfer in Micro-channels: a Review of Experimental Results. *Int. J. Therm. Sci.* 43(7), 631-651.
- [5] Qu, W., Mala, G.M. & Li, D.(2000). Heat transfer for water flow in trapezoidal silicon micro-channels. *Int. J. Heat Mass Transfer*, 43(21), 3925-3936.
- [6] Toh, K.C., Chen, X. Y., & Chai, J.C. (2002). Numerical computation of fluid flow and heat transfer in micro-channels. *Int. J. Heat Mass Transfer*, 45, 5133-5141.
- [7] Xu, B., K.T. Ooi, C. Mavriplis & Zaghoul, M.E. (2003). Evaluation of viscous dissipation in liquid flow in micro-channels. *Journal of Micro-channels and Micro-engineering.*, 13, 53-57.
- [8] Kandlikar, S.G., Joshi, S. & Tian, S. (2001). Effect of channel roughness on heat transfer and fluid flow characteristics at low Reynolds numbers in small diameter tubes. *Proceedings of NHTC'01-35th National Heat Transfer Conference, Anaheim CA, USA, paper 12134.*
- [9] Sharp, K.V. (2001). Experimental investigation of liquid and particle-laden flows in micro-tubes. Thesis submitted in partial fulfillment of the requirements for the degree of Doctor of Philosophy in Theoretical and Applied Mechanics in the Graduate College of the University of Illinois at Urbana-Champaign, Urbana, Illinois.
- [10] Sharp, K.V. & Adrian, R. J. (2004). Transition from Laminar to Turbulent Flow in Liquid Filled Micro-tubes. *Exp. Fluids*, 36, 741-747.
- [11] i, Z.X., Du, D. X. & Guo, Z.Y. (2003). Experimental study on flow characteristics of liquid in circular micro-tubes. *Micro-scale Thermophys. Eng.*, 7(3), 253-265.
- [12] Phares, D.J. & Smedley G.T., (2004). Study of laminar flow of polar liquid through circular micro-tubes. *International Phys Fluid*, 16(3), 1267-1272.
- [13] Celata, G.P., Cumo, M., McPhail, S. & Zummo, G. (2006). Characterization of fluid dynamic behavior and channel wall effects in micro-tube. *Int. J. Heat Fluid Flow*, 27, 135-143.
- [14] Zhao. I. & Liu, Z., (2006). Experimental studies on flow visualization and heat transfer characteristics in microtubes. *13th International Heat Transfer Conference. MIC-12: Sydney.*
- [15] Rahman M.M, (2000). Measurements of heat transfer in micro-channel heat sink. *Int. Commun. Heat Mass.* 27, 495-506.
- [16] Celata, G.P., Cumo, M., Guglielmi, M. & Zummo G. (2002). Experimental investigation of hydraulic and single-phase heat transfer in 0.130-MM capillary tube. *Nanoscale Micro-scale Thermophys. Eng.* 6(2), 85-97.
- [17] Kandlikar, S.G., Joshi S. & Tian S. (2003). Effect of surface roughness on heat transfer and fluid flow characteristics at low Reynolds number in small diameter tubes. *Heat Transfer Eng.* 24, 4-16.
- [18] Kandlikar, S.G., Schmitt, D., Carano, A. L. & Taylor, J. B. (2005). Characterization of surface roughness effects on pressure drop in single-phase flow in minichannels, *Phys. Fluids*, 17, 100606-(1-11).
- [19] Adams, T.M., Abdel-Khalik, S. I., Jeter, M. & Qureshi, Z. H. (1997). An Experimental investigation of single-phase forced convection in micro-channels, *Int. J. Heat Mass Transfer*, 41(6-7), 851-857.
- [20] Yang, C.-Y. & Lin, T.-Y. (2007). Heat transfer characteristics of water flow in microtubes, *Exp. Therm Flu sci.*, 32, 432-439.