

Distance Estimation for Radar Systems Using DS-UWB Signals

Youngpo Lee and Seokho Yoon

Abstract—In this paper, we propose a distance estimation scheme for radar systems using direct sequence ultra wideband (DS-UWB) signals. The proposed distance estimation scheme averages out the noise by accumulating the correlator outputs of the radar, and thus, helps the radar to employ a short-length DS-UWB signal reducing the correlation processing time. Numerical results confirm that the proposed distance estimation scheme provides a better estimation performance and a reduced correlation processing time compared with those of the conventional DS-UWB radars.

Keywords—Radar, DS-UWB, distance estimation, correlation accumulation.

I. INTRODUCTION

IN direct sequence ultra wideband (DS-UWB) radar systems, a distance between the radar and an object is estimated by transmitting a DS-UWB signal, and then, estimating the time delay until the reflected DS-UWB signal returns to the radar. Due to its high time resolution, the DS-UWB radar has attracted much interest as a distance estimation unit in vehicular parking assistance systems, vehicular pre-crash sensing systems, and security sensors [1]-[3]. As the length of the pseudo noise (PN) sequence used in the DS-UWB radar becomes larger, a higher correlation gain can be achieved, resulting in a more reliable distance estimate. However, a long PN sequence calls for a large amount of correlation processing time [4], and thus, it is not suitable for time-sensitive applications such as vehicular pre-crash sensing systems where a fast distance estimation is required to avoid a collision between a vehicle and an obstacle.

Thus, DS-UWB radar schemes using variable PN sequence length [5]-[7] have been proposed, where multiple PN sequences with various lengths are employed instead of a single long PN sequence and the PN sequence length is selected based on the standard deviation of the estimated distances, thus reducing the correlation processing time while keeping the estimation performance. Nonetheless, the schemes still have a long correlation processing time at low signal-to-noise ratios (SNRs) since the standard deviation becomes larger at low SNRs, and thus, long-length sequences are required to maintain the performance.

In this paper, we propose a novel distance estimator for radar systems using DS-UWB signals. Since the fluctuated noise in each correlation output is independent, the correlation accumulation process of the proposed distance estimator averages out the noise, and thus, allows us to employ a single short-length

PN sequence in the overall SNR range of practical interest, and eventually, to reduce the overall correlation processing time.

The rest of the paper is organized as follows: Section II introduces the DS-UWB radar system and the proposed and conventional distance estimators. Then, in Section III, performances of the proposed and conventional radars are compared in terms of the average correlation processing time (ACPT) and root mean square error (RMSE). Finally, Section IV concludes the paper.

II. PROPOSED DS-UWB RADAR SYSTEM

Figure 1(a) shows the structure of the DS-UWB radar system for estimating the distance D between the radar and an object. First, the DS-UWB signal

$$s(t) = \sqrt{E_c} \sum_{j=0}^{N-1} p_j g(t - jT_c) \quad (1)$$

is transmitted to the object, where E_c is the chip energy of the PN sequence with a length of N chips, $p_j \in \{-1, +1\}$ is the j th chip, T_c is the chip duration, and

$$g(t) = \left[1 - 4\pi \left(\frac{t - T_c/2}{\gamma} \right)^2 \right] \exp \left[-2\pi \left(\frac{t - T_c/2}{\gamma} \right)^2 \right] \quad (2)$$

is a UWB pulse with unit energy over $[0, T_c]$, where the time normalization factor γ is set to $\sqrt{4\pi}/7T_c$, making 99.99% of the total waveform energy included within the chip duration [8]. The transmitted signal is reflected by the object and returns to the receiver with a delay τ , and thus, the received signal $r(t)$ is obtained as

$$r(t) = s(t - \tau) + w(t), \quad (3)$$

where $w(t)$ is an additive white Gaussian noise process with mean zero and double-sided power spectral density $N_0/2$. Subsequently, the received signal is correlated with a reference signal with a candidate delay $\tilde{\tau} \in \Delta = \{0, T_c, 2T_c, \dots, (N-1)T_c\}$, yielding the m th correlator output

$$\begin{aligned} R_m(\tau, \tilde{\tau}) &= \int_{(m-1)NT_c}^{mNT_c} r(t)s(t - \tilde{\tau})dt \\ &= E_c S(\tau, \tilde{\tau}) + W_m \end{aligned} \quad (4)$$

Y. Lee and S. Yoon are with College of Information and Communication Engineering, Sungkyunkwan University, Suwon, Korea.

Corresponding author (e-mail: syoon@skku.edu)

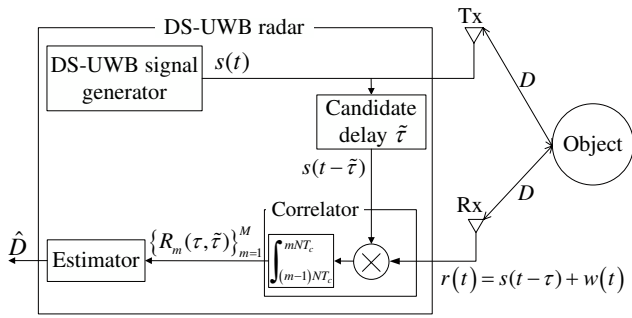

(a) The structure of the DS-UWB radar

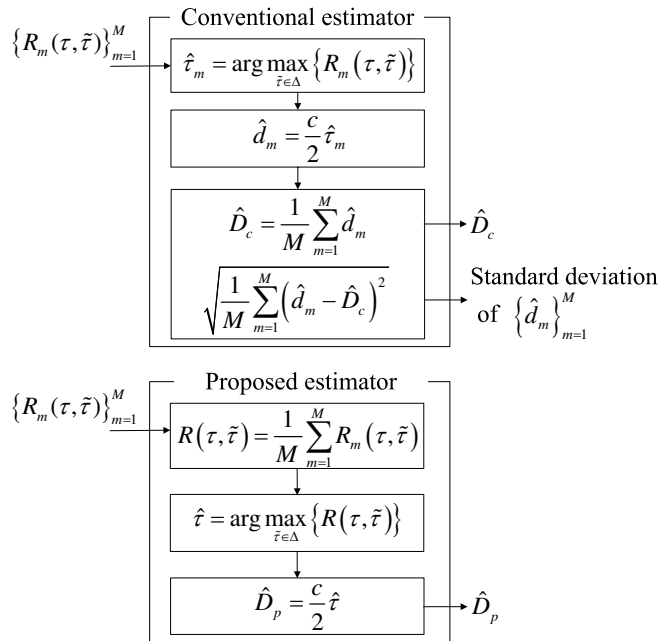

(b) The estimator structures of the conventional and proposed DS-UWB radars

Fig. 1. The structure of the distance measuring unit of conventional and proposed DS-UWB radars

for $m = 1, 2, \dots, M$, where M is the number of correlations,

$$S(\tau, \tilde{\tau}) = \begin{cases} N \left[1 - 4\pi \left(\frac{\tilde{\tau} - \tau}{\gamma} \right)^2 + \frac{4\pi^2}{3} \left(\frac{\tilde{\tau} - \tau}{\gamma} \right)^4 \right] e^{-\pi \left(\frac{\tilde{\tau} - \tau}{\gamma} \right)^2} & \text{for } |\tilde{\tau} - \tau| \leq T_c, \\ -1 & \text{for } |\tilde{\tau} - \tau| > T_c \end{cases} \quad (5)$$

is the autocorrelation function of $g(t)$ [9], and $\{W_m\}_{m=1}^M$ are zero-mean independent identically distributed Gaussian random variables with variance $NT_c N_0/2$. Finally, the estimator yields a distance estimate \hat{D} using $\{R_m(\tau, \tilde{\tau})\}_{m=1}^M$ as shown in Figure 1(b): In the conventional estimators, $\{R_m(\tau, \tilde{\tau})\}_{m=1}^M$ are exploited individually, i.e., M delay estimates $\{\hat{\tau}_m\}_{m=1}^M$ (and consequently, M distance estimates $\{\hat{d}_m\}_{m=1}^M = \{c\hat{\tau}_m/2\}_{m=1}^M$, where c is the speed of light) are individually obtained per correlator output and the final distance estimate \hat{D}_c is obtained by averaging $\{\hat{d}_m\}_{m=1}^M$. In addition, the standard deviation of $\{\hat{d}_m\}_{m=1}^M$ is yielded for selection of the PN sequence length. In the proposed

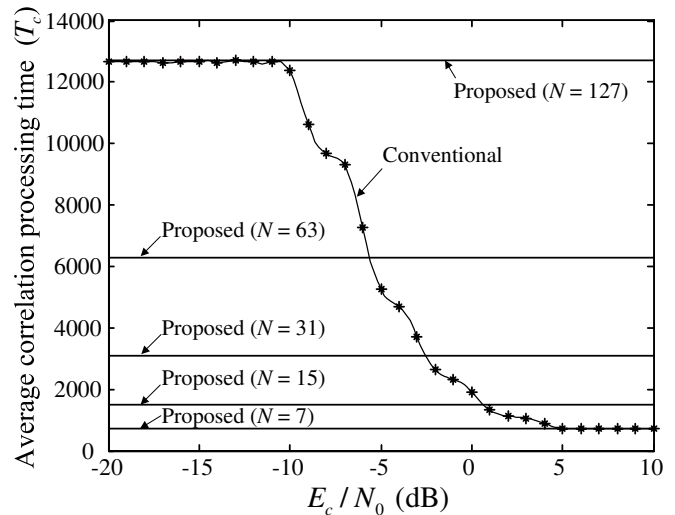

Fig. 2. The average correlation processing time of the proposed and conventional schemes as a function of E_c/N_0 when $D = 30$ m.

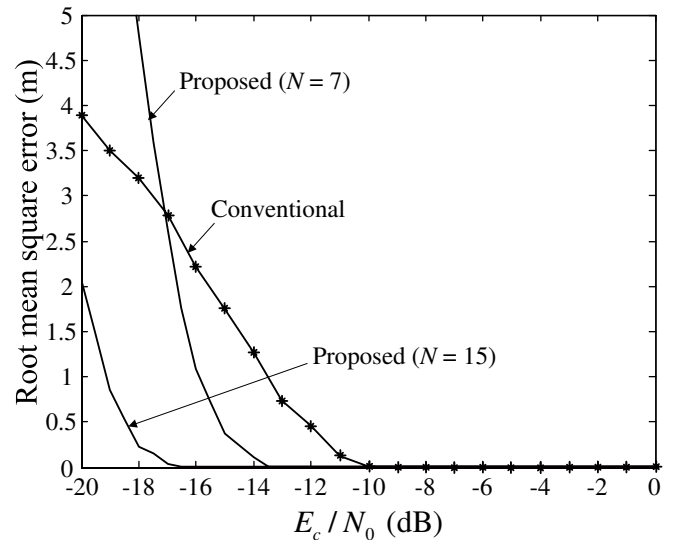

Fig. 3. The root mean square error of the proposed and conventional schemes as a function of E_c/N_0 when $D = 30$ m.

estimator, on the other hand, a single delay estimate $\hat{\tau}$ and the corresponding distance estimate \hat{D}_p are made through $R(\tau, \tilde{\tau}) = \frac{1}{M} \sum_{m=1}^M R_m(\tau, \tilde{\tau})$ obtained by accumulating M correlator outputs. It is easy to see that the noise variance of $R(\tau, \tilde{\tau})$ is reduced by a factor of M than that of $R_m(\tau, \tilde{\tau})$, and thus, it is expected that the proposed DS-UWB radar performs better than the conventional radars when a PN sequence with the same length is employed.

III. NUMERICAL RESULTS

In this section, the proposed and conventional DS-UWB radars are compared in terms of the ACPT, which is the time required to obtain an estimate \hat{D} on the average, and RMSE, i.e., $\sqrt{E[(D - \hat{D})^2]}$, where $E[\cdot]$ denotes the statistical expectation. For simulations, we assume the following parameters: $M = 100$, $N = 7, 15, 31, 63$, and 127 chips. For the best

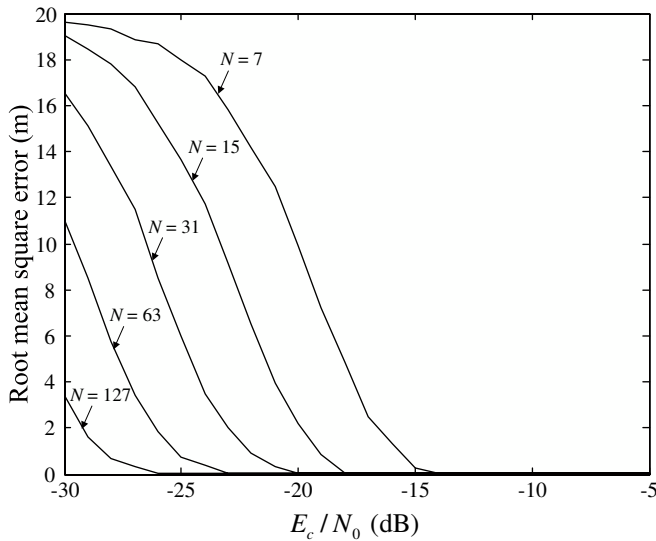

Fig. 4. The root mean square error of the proposed and conventional schemes as a function of distance when $E_c/N_0 = -20$ dB.

performance of the conventional DS-UWB radar, we have first numerically obtained and then employed the optimum value of the standard deviation of $\{\hat{a}_m\}_{m=1}^M$.

Figures 2 and 3 show the ACPT in chips and RMSE of the proposed and conventional DS-UWB radars as a function of E_c/N_0 , respectively, where the ACPT of the proposed DS-UWB radar is constant regardless of the SNR values since it uses a single PN sequence unlike the conventional one using variable PN sequence length. Here, we consider a fixed distance of $D = 30$ meters (the maximum detectable range for short range radars [10]). From the figures, it is observed that the proposed radar employing a single PN sequence with a length of 15 provides a shorter ACPT and at the same time a better RMSE performance over the conventional radar using multiple PN sequences including a long PN sequence with a length of 127 chips in the SNR range $-20 \sim 0$ dB of practical interest. In addition, Figure 4 demonstrates that the proposed radar employing a PN sequence with a length of 15 outperforms the conventional radar in the detection range for short range radars (i.e., $D \leq 30$). This is because the proposed radar can offer a more reliable distance estimate only with a single short PN sequences by averaging out the noise effect through the accumulation of the correlations, unlike the conventional radar exploiting the correlations individually.

Table I shows the computational complexity in estimating the distance for proposed and conventional DS-UWB radars, where a flop is defined as a real floating point operation, and a real addition or multiplication is counted as one flop [11]. Although the number of flops required in the proposed radar can be generally larger than that of conventional radars, the difference would be insignificant since the recent Intel microprocessor is ideally capable of 4 flops per clock (i.e., a 2.5-GHz Intel microprocessor has a theoretical peak performance of 10 billion flops per second) [12].

TABLE I
 COMPUTATIONAL COMPLEXITY OF THE PROPOSED AND CONVENTIONAL DS-UWB RADARS.

Radar system	Number of addition	Number of multiplication	flop
Conventional	$3M - 2$	$3M + 2$	$6M$
Proposed	$(N - 1)M$	3	$(N - 1)M + 3$

IV. CONCLUSION

In this paper, we have proposed a distance estimation scheme for DS-UWB radar systems. The DS-UWB radar with the proposed distance estimator employs a short-length DS-UWB signal by virtue of the correlation accumulation, thus reducing correlation processing time. From numerical results, we have demonstrated that the DS-UWB radar employing the proposed distance estimator can provide a shorter ACPT and a better RMSE performances compared with those of the conventional DS-UWB radars.

ACKNOWLEDGMENT

This research was supported by the National Research Foundation (NRF) of Korea under Grant 2012R1A2A2A01045887 with funding from the Ministry of Science, ICT&Future Planning (MSIP), Korea, by the Information Technology Research Center (ITRC) program of the National IT Industry Promotion Agency under Grant NIPA-2013-H0301-13-1005 with funding from the MSIP, Korea, and by National GNSS Research Center program of Defense Acquisition Program Administration and Agency for Defense Development.

REFERENCES

- [1] M. G. M. Hussain, "Ultra-wideband impulse radar: An overview of the principles," *IEEE Aerosp. Electron. Syst. Mag.*, vol. 13, no. 9, pp. 9-14, Sep. 1998.
- [2] I. Y. Immoreev, S. Samkov, and T.-H. Tao, "Short-distance ultrawideband radars," *IEEE Aerosp. Electron. Syst. Mag.*, vol. 20, no. 6, pp. 9-14, June 2005.
- [3] H. Dominik, "Short range radar-status of UWB sensors and their applications," in *Proc. European Radar Conf. (EuRAD)*, pp. 251-254, Munich, Germany, Oct. 2007.
- [4] S. J. Xu, Y. Chen, and P. Zhang, "Integrated radar and communication based on DS-UWB," in *Proc. Int. Conf. Ultrawideband and Ultrashort Impulse Signals (UWBUSIS)*, pp. 142-144, Sevastopol, Ukraine, Sep. 2006.
- [5] Y. Nakayama and R. Kohno, "Novel variable spreading sequence length system for improving the processing speed of DS-UWB radar," in *Proc. Int. Conf. Intelligent Transport Syst. Telecommun. (ITST)*, pp. 357-361, Phuket, Thailand, Oct. 2008.
- [6] J. Tsuchiya, M. Hayashi, and R. Kohno, "Platoon characteristics of automatic vehicle speed control for vehicles equipped with DS-UWB radar," in *Proc. Int. Symp. Spread Spectrum Techniques and Applications (ISSSTA)*, pp. 125-130, Taichung, Taiwan, Oct. 2010.
- [7] S. G. Kang, Y. Lee, J. Kim, D. Chong, J. Baek, and S. Yoon, "A distance measuring scheme based on repeated use of PN sequence," in *Proc. Asia-Pacific Conf. Commun. (APCC)*, CD-ROM, Kota Kinabalu, Malaysia, Oct. 2011.
- [8] H. Chen, T. A. Gulliver, W. Li, and H. Zhang, "Performance of ultrawideband communication systems using DS-SS PPM with BCH coding over a fading channel," in *Proc. Military Commun. Conf. (MILCOM)*, pp. 1-5, Washington, DC, Oct. 2006.
- [9] B. Hu and N. C. Beaulieu, "Accurate evaluation of multiple-access performance in TH-PPM and TH-BPSK UWB systems," *IEEE Trans. Commun.*, vol. 52, no. 10, pp. 1758-1766, Oct. 2004.

- [10] K. M. Stroh, H.-L. Bloecher, R. Schneider, and J. Wenger, "Development of future short range radar technology," in *Proc. European Radar Conf. (EuRAD)*, pp. 165-168, Paris, France, Oct. 2005.
- [11] H. Liu, L. Hao, and P. Fan, "A low-complexity scheduling scheme for multiuser MIMO system based on Tomlinson-Harashima precoding," in *Proc. Int. Conf. Inform. Theory and Inform. Security (ICITIS)*, pp. 981-984, Beijing, China, Dec. 2010.
- [12] J. Brown, "Efficient nonlinear solvers for nodal high-order finite elements in 3D," *J. Scientific Computing*, vol. 45, no. 1-3, pp. 48-63, Oct. 2010.

Youngpo Lee received the B.S.E. and M.S.E. degrees in information and communication engineering from Sungkyunkwan University, Suwon, Korea, in 2008 and 2010, respectively. He is currently working toward the Ph.D. degree in the College of Information and Communication Engineering, Sungkyunkwan University. His research interests include binary offset carrier modulation, orthogonal frequency division multiplexing (OFDM) systems, and cognitive radio.

Seokho Yoon received the B.S.E. (summa cum laude), M.S.E., and Ph.D. degrees in electrical engineering from Korea Advanced Institute of Science and Technology (KAIST), Daejeon, Korea, in 1997, 1999, and 2002, respectively. From April 2002 to June 2002, he was with the Department of Electrical Engineering and Computer Science, Massachusetts Institute of Technology (MIT), Cambridge. From July 2002 to February 2003, he was with the Department of Electrical Engineering, Harvard University, Cambridge, as a Postdoctoral Research Fellow. In March 2003, he joined the College of Information and Communication Engineering, Sungkyunkwan University, Suwon, Korea, where he is currently an Associate Professor. His research interests include spread spectrum systems, mobile communications, detection and estimation theory, and statistical signal processing.