

Modified Buck Boost Circuit for Linear and Non-Linear Piezoelectric Energy Harvesting

I Made Darmayuda, Chai Tshun Chuan Kevin, and Je Minkyu

Abstract—Plenty researches have reported techniques to harvest energy from piezoelectric transducer. In the earlier years, the researches mainly report linear energy harvesting techniques whereby interface circuitry is designed to have input impedance that match with the impedance of the piezoelectric transducer. In recent years non-linear techniques become more popular. The non-linear technique employs voltage waveform manipulation to boost the available-for-extraction energy at the time of energy transfer. The fact that non-linear energy extraction provides larger available-for-extraction energy doesn't mean the linear energy extraction is completely obsolete. In some scenarios, such as where initial power is not available, linear energy extraction is still preferred. A modified Buck Boost circuit which is capable of harvesting piezoelectric energy using both linear and non-linear techniques is reported in this paper. Efficiency of at least 64% can be achieved using this circuit. For linear extraction, the modified Buck Boost circuit is controlled using a fix frequency and duty cycle clock. A voltage sensor and a pulse generator are added as the controller for the non-linear extraction technique.

Keywords—Buck boost, energy harvester, linear energy harvester, non-linear energy harvester, piezoelectric, synchronized charge extraction.

I. INTRODUCTION

MECHANICAL vibration energy can be converted into electrical energy with the aid of piezoelectric transducer. The abundance of mechanical vibration energy sources in the environment makes piezoelectric energy harvesting as an ideal source for renewable energy. The AC nature and high input impedance pose challenges in harvesting energy from piezoelectric transducer. Various researches have been done to maximize the amount of extracted energy from piezoelectric transducer. In [1]-[5] linear techniques are presented to optimize the energy extraction. In recent years, more non-linear extraction techniques have been reported such as in [6]-[11]. Linear and non-linear techniques have their own advantages and disadvantages. For example, non-linear energy extraction technique is claimed to extract substantially more power, however it comes with the price of high precision sensor is required. Hence non-linear extraction technique can not completely replace the linear extraction technique.

The pattern and frequency combination of vibrations in the environment are infinite. It is impossible to use a single harvesting technique to fit best in every single situation.

D. I Made, T. C. K. Chai, and M. Je are with the Institute of Microelectronics, A*STAR, Singapore 117685 (phone: (65) 6770-5583; fax: (65) 6774-5754; e-mail: imaded@ime.a-star.edu.sg).

Converting these vibrations into electrical energy requires adjustment to each specific vibration source. Choosing the right technique is critical for maximum energy extraction.

In this paper, a modified Buck Boost circuit is presented. Depending on the controllers used; the circuit designed here can be used to harvest energy with both linear and non-linear technique. The linear harvesting is realized by providing matching input impedance to the transducer, while the non-linear harvesting uses synchronized charge extraction (SCE) method. With this flexibility the circuit is capable of harvesting energy from wide variety of vibration sources.

II. MODIFIED BUCK BOOST CIRCUIT

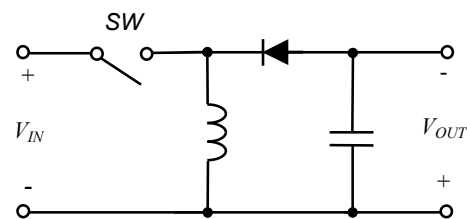

Fig. 1 Buck Boost circuit configuration

The conventional use of a Buck Boost circuit is to convert DC input voltage into DC output voltage which is either bigger or smaller than the input voltage. The magnitude of the output voltage depends on the duty cycle (D). When the duty cycle is larger than 50% the magnitude of the output voltage is larger than the input voltage. Lower output voltage magnitude is achieved by setting the duty cycle to be less than 50%. The input and output voltage relationship is describes by the following equation:

$$\frac{V_{OUT}}{V_{IN}} = \frac{D}{1-D} \quad (1)$$

In Fig. 1 conventional configuration of buck boost circuit is presented. The Buck Boost circuit consists of a switch, an inductor, a diode and a capacitor. There are two phase in operation of the Buck Boost circuit, namely inductor charging and discharging. The inductor charging phase takes place when switch SW is on. When the switch SW is off the inductor discharging phase occurs, transferring all the storage charge from the inductor to the storage capacitor.

When operated in Discontinuous Conduction Mode (DCM) the Buck Boost exhibits a unique property. In DCM operation

the input and output impedance of the Buck Boost circuit is independent of each other. This impedance isolation makes the Buck Boost circuit as a perfect candidate for linear energy harvester [5].

It is apparent that the output voltage of the conventional Buck Boost circuit has opposite polarity of the input voltage. This creates complication when the Buck Boost circuit is implemented in IC technology. A modified non-inverting Buck Boost converter is designed here to overcome this limitation. In this modified Buck Boost circuit, two additional switches are added as shown in Fig. 2. During the inductor charging phase, *SW1* and *SW2* are on while *SW3* is off. Inductor discharging phase takes place when *SW2* is on while *SW1* and *SW3* are off.

Charge transfer process of the modified Buck Boost circuit is similar to the non-linear energy harvester technique called Synchronized Charge Extraction (SCE) presented in [7]. With appropriate control method, SCE energy harvesting technique can be also implemented using the modified Buck Boost circuit.

To complete the energy extraction circuit, rectifier is essential for the front-end. The overall buck-boost circuit is presented in Fig. 3. The voltage rectifier is constructed by PMOS and NMOS transistors connected back to back. There is no voltage storage required at the rectifier output of linear and non-linear energy harvester methods. Hence, reverse current associated with voltage rectifier is not a concern. Higher efficiency is achieved with voltage rectifier due to its voltage drop is only $2V_{DS}$ compared to $2V_{TH}$ voltage drop in diode-based rectifier [12].

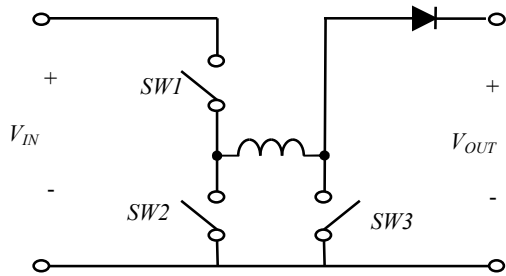

Fig. 2 Modified Buck Boost circuit

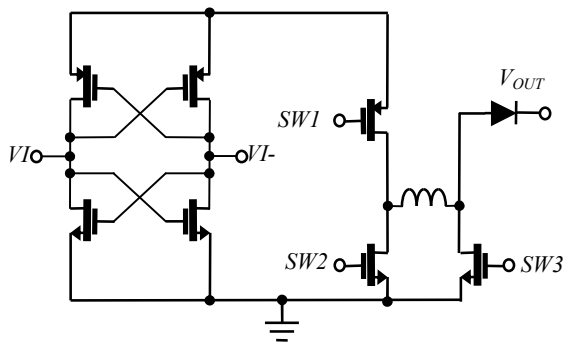

Fig. 3 Buck Boost energy harvester circuit

III. BUCK BOOST AS LINEAR HARVESTER

The essence of linear energy harvesting is matching the transducer's impedance with the load impedance [3]. The piezoelectric transducer can be modeled as a sinusoid current source ($I \sin(2\pi f)$) in parallel with a capacitor (C_{PZ}). For optimum power transfer, the load seen by the transducer must be equal to:

$$R_{IN} = \frac{1}{2\pi f C_{PZ}} \quad (2)$$

In DCM operation Buck Boost converter has purely resistive input impedance [4], [5]. The input impedance of the buck-boost circuit can be described by the following equation:

$$R_{IN} = \frac{2Lf_{SW}}{D_{SW}^2} \quad (3)$$

where L is the inductor size and f_{SW} and D_{SW} are the switching frequency and duty cycle respectively. From the equation, it is clear that input and output voltages are absent in the equation. This fact greatly reduce the controller complexity and also power consumption as neither input nor output monitoring are required to achieved desired input impedance for the Buck Boost converter.

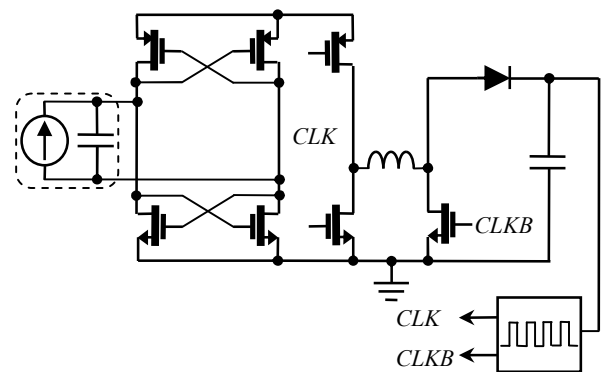

Fig. 4 Modified Buck Boost circuit as linear energy harvester

In Fig. 4, the modified Buck Boost circuit is configured as linear energy harvester. The controller used here is a simple ring oscillator with fix frequency and duty cycle. During one clock-cycle, the input voltage of Buck-Boost converter must remain relatively constant. Hence, the clock frequency used must be much larger than the vibration frequency. The DCM operation is ensured by using small duty cycle.

Fig. 5 shows the current starved ring oscillator circuit [13]. A simple current reference can be added as the current source. With current-starved topology, the oscillator frequency can be described as:

$$f_{OSC} = \frac{I_{BIAS}}{NC_{EFF}V_{DD}} \quad (4)$$

where I_{BIAS} , N , and C_{EFF} are bias current, number of chain inverters, and effective capacitive load respectively. While the bias current is equal to:

$$I_{BIAS} = \frac{V_{DD} - V_{GS}}{R} \quad (5)$$

where V_{GS} and R are the gate-to-source voltage and biasing resistor respectively. If V_{GS} is much smaller than V_{DD} , combination of (4) and (5) result in:

$$f_{OSC} = \frac{1}{NC_{EFF}R} \quad (6)$$

Based on (6), the combination of current-starved ring oscillator and simple current source result in fix-frequency ring oscillator.

Another beauty of this linear energy extraction technique is that initial power is not required. When the initial output voltage is zero, the ring oscillator is not working and both CLK and CLKB signal are zero. In this situation, both NMOS switches are turned off while the PMOS is turned on, providing direct charging path to the output capacitor.

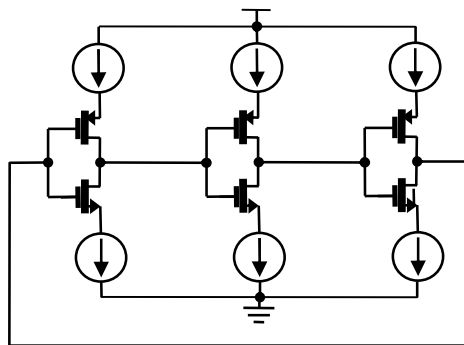

Fig. 5 Current-starved ring oscillator

IV. BUCK BOOST AS NON-LINEAR HARVESTER

Other than linear energy harvesting the modified buck-boost circuit can also be configured as non-linear energy extraction with SCE technique. In this energy extraction technique the transducer voltage waveform is modified such that at the time of extraction the output voltage is twice of the open loop condition [7]. In Fig. 5, modified Buck Boost circuit is configured as SCE energy harvester. This is done by adding voltage sensor and adjustable pulse generator. The voltage sensor detects the peak voltage of the transducer after rectification and the pulse generator controls the harvesting duration.

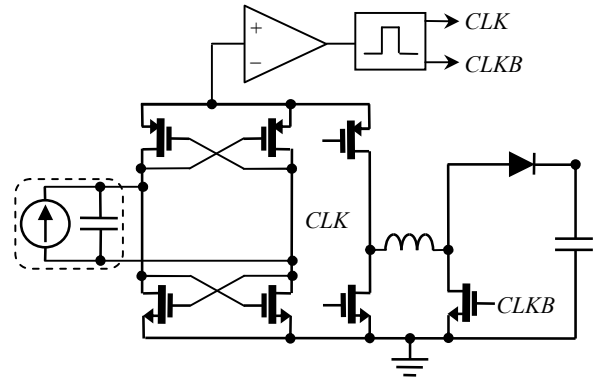

Fig. 6 Modified Buck Boost circuit as non-linear energy harvester

In the SCE harvester technique, the energy extraction timing is synchronized with the transducer vibration. When the transducer voltage reaches its maximum or minimum value both PMOS and right-side NMOS switch are turned on while the left-side NMOS is turned off. The circuit is at this state for duration of $0.5\pi\sqrt{L_{SCE}C_{PZ}}$ s. When all the charge are transferred from the transducer to the inductor, the transducer voltage drop to zero and then the left-side NMOS switch is turned on while right-side NMOS and PMOS switches are turned off. During this period the charge is transferred from the inductor to the storage capacitor. The duration of the charge transfer must be set much lower than the transducer's vibration period by choosing appropriate inductor (L_{SCE}) value.

Theoretically the amount of available-for-extraction energy of the non-linear technique is $8/\pi$ times of the linear technique. The explanation is as the following. In SCE energy harvesting, the transducer's equivalent current source charges the equivalent capacitor for a half period in open loop condition. With assumption of ideal rectifier is used, the peak voltage of the rectified transducer is equal to:

$$V_{REC(MAX)} = \frac{1}{C_{PZ}} \int_0^{\pi/\omega} I \sin(\omega t) dt \quad (7)$$

$$V_{REC(MAX)} = \frac{2I}{\omega C_{PZ}}$$

In one cycle, there are twice extractions done. Hence, the average power of the available-for-extraction energy at the voltage rectifier output is equal to:

$$P_{SCE} = \frac{1}{2} C_{PZ} V_{PZ(MAX)}^2 \frac{2}{T} \quad (8)$$

$$P_{SCE} = \frac{2I^2}{\pi\omega C_{PZ}}$$

While the maximum power level of the linear extraction

method at the same point is only $\frac{I^2}{4\omega C_{PZ}}$ [11].

V. RESULTS AND DISCUSSIONS

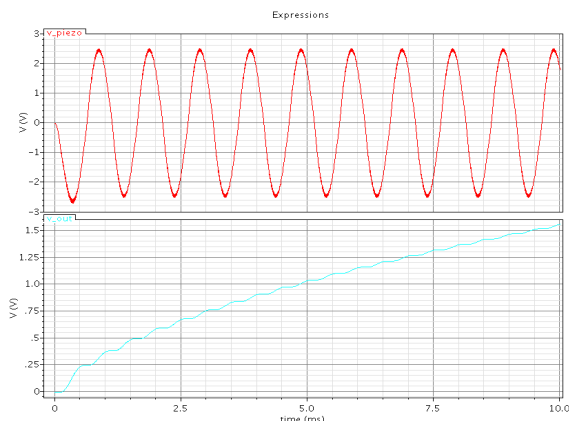

(a)



(b)

Fig. 7 Linear extraction waveforms with modified Buck Boost Circuit

In this simulation, the piezoelectric is modeled by a sinusoid current source with 1 KHz frequency in parallel with 10nF capacitor in the simulation. Based on the modeling, the Buck Boost is expected to provide 16KΩ input impedance for optimum power transfer. Fig. 7 (a) shows the input and output waveforms of energy extraction using modified Buck Boost circuit as linear extraction to charge a 1μF capacitor. After 10ms the capacitor voltage becomes 1.56V which means 1.217μJ energy is collected within this period. Detailed waveforms consist of (from top to bottom): transducer's voltage, control clock, inductor current, and output voltage are presented in Fig. 7 (b). A 100 KHz clock with 5% duty cycle is used as the controller. With small duty cycle DCM operation is achieved which is confirmed by the inductor's current waveform. 40μH inductor is used to make the input impedance of the modified Buck Boost circuit to be 16KΩ.

The input and output voltage waveforms are presented in Fig. 8 (a). The transducer voltage waveform is no longer

sinusoid as in linear energy harvester technique. Instead, it drops suddenly when maximum/minimum voltage is achieved. The peak voltage is also larger than in the linear extraction technique. The voltage and energy collected at the 1μF output capacitor after 10ms are 1.97V and 1.94μJ respectively.

Zoomed version of transducer voltage, controller, inductor, output voltage waveforms of the SCE extraction technique are presented in Fig. 8 (b). When the control signal is high, the transducer voltage drops and inductor current increases showing charge is transferred from transducer to inductor. The control signal's on-time duration is approximately 3μs for transducer with 10nF capacitance harvested by SCE with 400μH inductor. After the control signal goes to zero again, the inductor current decreases and the output voltage increases. During this period, the charge is transferred from the inductor to the storage capacitor.

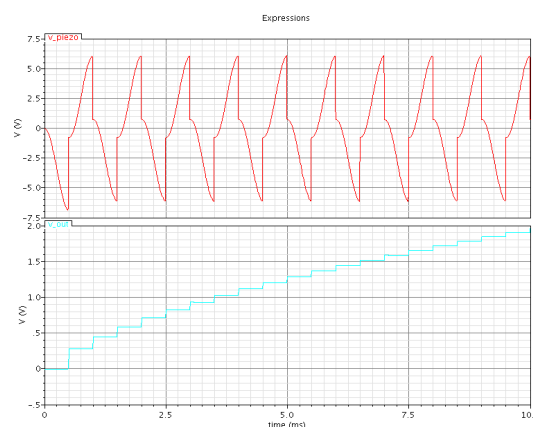

(a)

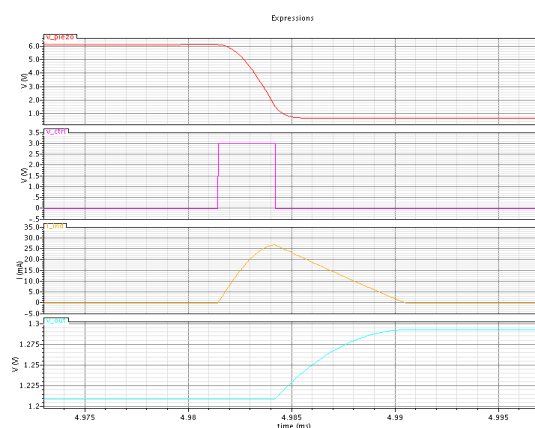

(b)

Fig. 8 Non-linear extraction waveforms with modified Buck Boost Circuit

The average power extracted using linear method over 10ms is 121μwatt against input power of 188μwatt. Meanwhile with the same input and time duration the average power harvested using the non-linear technique is 194μwatt against input power of 380μwatt. As expected the energy extracted using non-

linear technique is larger than linear technique. The efficiency of the linear and non-linear techniques is 64% and 51% when their respective input power is used as the denominator. However when the input power of linear extraction is used as the denominator of both methods, the efficiency of linear and non-linear technique becomes 64% and 103%, respectively.

Accurate peak detector is required for the non-linear technique while the linear technique only requires simple ring oscillator as the controller. When the energy generated by the transducer is too low, linear extraction technique is more suitable due to its lower power consumption. The non-linear technique is also must be able to handle higher voltage level due to its voltage manipulation results in higher input voltage for the same transducer. In Table I, the summary of comparison between linear and non-linear extraction method is presented.

TABLE I
 COMPARISON OF LINEAR & NON-LINEAR EXTRACTION WITH MODIFIED BUCK BOOST CIRCUIT

Parameter	Linear Extraction	Non-Linear Extraction
Principles	Impedance matching	Voltage boosting at extraction point
Controller	Clock with fix frequency and duty cycle	Voltage sensor and pulse generator
Initial power	Not required	Required
Theoretical maximum voltage	Half the open loop condition	Twice the open loop condition
Average energy at Buck Boost input	$I^2 / 4\omega C_{PZ}$	$2I^2 / \pi\omega C_{PZ}$
Efficiency	64%	103%*

* The denominator used is the input energy of the linear energy extraction.

VI. CONCLUSIONS

The fact that non-linear energy extraction technique is capable of harvesting substantially larger energy doesn't mean that linear energy extraction technique is totally obsolete. In some situation such as when energy generated is too low or the absent of initial power, linear extraction method is still preferred. In this paper design of modified Buck Boost circuit which can be operated both as linear and non-linear energy extractor is presented. With this flexibility the modified Buck Boost circuit is suitable to harvest piezoelectric energy in almost all conditions.

REFERENCES

- [1] G. K. Ottman, H. F. Hofmann, G. A. Lesieutre, "Optimized Piezoelectric Energy Harvesting Circuit Using Step-Down Converter in Discontinuous Conduction Mode", IEEE Transactions on Power Electronics, vol. 18, pp. 696-703, Mar. 2003
- [2] H Kim, S Priya, H Stephanou, K Uchino, "Consideration of Impedance Matching Techniques for Efficient Piezoelectric Energy Harvesting", IEEE Transactions on Ultrasonic, Ferroelectrics, and Frequency Control", vol. 54, pp. 1851-1859, Sep. 2007
- [3] E. Lefeuvre, D. Audigier, C. Richard, D. Guyomar, "Buck-Boost Converter for Sensorless Power Optimization of Piezoelectric Energy Harvester", IEEE Transactions on Electronics, vol. 22, pp. 2018-2025, Sep. 2007
- [4] R. D'hulst, T. Sterken, R. Puers, G. Deconinck, J. Driesen, "Power Processing Circuits for Piezoelectric Vibration-Based Energy Harvester", IEEE Transactions on Industrial Electronics, vol. 57, pp. 4170-4177, 2010
- [5] D. I Made, Y. Gao, M. T. Tan, S. J. Cheng, Y. Zheng, M. Je, C.H. Heng, "A Self-Powered Power Conditioning IC for Piezoelectric Energy Harvesting From Short-Duration Vibrations", IEEE Transactions on Circuits and Systems, vol. 59, pp. 578-582, Sep. 2012
- [6] E. Lefeuvre, A. Badel, C. Richard, L. Petit, and D. Guyomar, "A Comparison between Several Vibration-Powered Piezoelectric Generators for Standalone Systems", Sensors and Actuators A: Physical, vol. 126, pp. 405-416, Feb. 2006
- [7] Y. K. Tan, J. Y. Lee, and S. K. Panda, "Maximize Piezoelectric Energy Harvesting Using Synchronous Charge Extraction Technique for Powering Autonomous Wireless Transmitter", IEEE International Conference on Sustainable Energy Technologies, pp. 1123-1128, Nov. 2008
- [8] D. Kwon, G. A. Rincon-Mora, "A 2- μ m BiCMOS Rectifier-Free AC-DC Piezoelectric Energy Harvester-Charger IC", IEEE Transactions on Biomedical Circuits and Systems, vol. 4, pp. 400-409, 2010
- [9] T. Hehn, F. Hagedorn, D. Maurath, D. Marinkovic, I. Kuehne, A. Frey, Y. Manoli, "A Fully Autonomous Integrated Interface Circuit for Piezoelectric Harvesters", IEEE Journal of Solid-State Circuits, vol. 47, no. 9, Sep. 2012
- [10] D. Kwon, G. A. Rincon-Mora, "Energy-Investment Schemes for Increasing Power in Piezoelectric Harvester", IEEE International Midwest Symposium on Circuits and Systems, pp. 1084-1087, 2012
- [11] J. Dicken, P. D. Mitcheson, I. Stoianov, E. M. Yeatman, "Power-Extraction Circuits for Piezoelectric Energy Harvesters in Miniature and Low-Power Applications", IEEE Transaction on Power Electronics, pp. 4514-4529, 2012
- [12] S. S. Hashemi, M. Sawan, Y. Savaria, "A High Efficiency Low-Voltage CMOS Rectifier for Harvesting Energy in Implantable Devices", IEEE Transactions on Biomedical Circuits and Systems, vol. 6, pp.326-335, 2012
- [13] X. Zhang, A. B. Apsel, "A Low Variation GHz Ring Oscillator with Addition-based Current Source", European Solid State Device Research Conference, pp. 216-219, 2009.