

# Separation of Dissolved Gases from Water for a Portable Underwater Breathing

Pil Woo Heo and In Sub Park

**Abstract**—Water contains oxygen which may make a human breathe under water like a fish. Centrifugal separator can separate dissolved gases from water. Carrier solution can increase the separation of dissolved oxygen from water. But, to develop an breathing device for a human under water, the enhancement of separation of dissolved gases including oxygen and portable devices which have dc battery based device and proper size are needed.

In this study, we set up experimental device for analyzing separation characteristics of dissolved gases including oxygen from water using a battery based portable vacuum pump. We characterized vacuum state, flow rate of separation of dissolved gases and oxygen concentration which were influenced by the manufactured vacuum pump.

**Keywords**—Portable, breathing, water, separation, battery.

## I. INTRODUCTION

WATER contains oxygen which may make a human breathe under water like a fish. An inventor in Israel reported the possibility of breathing using dissolved gases which were separated from water with the centrifugal separator. Yang et al reported several artificial gills for small animals [1]. They showed the possibility of artificial gills using microporous hollow fibers. Comparing with parallel direction, cross-flow module had an inherently higher value of the mass transfer coefficient and was more efficient.

Separation of dissolved oxygen using carrier solutions which had high concentration of oxygen was introduced [2], [3]. To separate dissolved gas from water using carrier solution was more efficient than to separate directly from water without carrier solution. Carrier solution had characteristics with high solubility for oxygen and the solubility could be changed by temperature or light. At first, water contacted to carrier solution and then dissolved gas could be separated from the carrier solution with rich oxygen by increasing temperature. Then before contacting to water, carrier solution requested to be cooled to get higher capacity which could transfer oxygen from water. Another carrier solution could be changed by emitting light. By controlling the amounts of light, it was possible for us to take advantage of oxygen separated from water. Sometimes it can be more useful for minimizing to use light than to use heat exchange. Selection of carrier solution depends on application areas and performance of separation.

We investigated the separation characteristics of dissolved gases using the pipe type of hollow fiber membrane with

P. W. Heo is with the Korea Institute of Machinery and Materials, Daejeon, Korea (phone: 42-868-7331; fax: 42-868-7335; e-mail: pwheo@kimm.re.kr).

I. S. Park is with the Korea Institute of Machinery and Materials, Daejeon, Korea (e-mail: ispark@kimm.re.kr).

polypropylene and the nude type of one with polysulfone [4]. The combination of membranes with good separation characteristics under water and good transferring one in an air was introduced to breathe instantly under water to be alive at crisis.

But, to develop a breathing device for a human under water, the enhancement of separation of dissolved gases including oxygen and portable devices which has dc battery based device and proper size are needed.

In this study, we set up experimental device for analyzing separation characteristics of dissolved gases including oxygen from water using a battery based portable vacuum pump. It includes the manufactured vacuum pump, hollow fiber membrane, a mass flow meter and an oxygen sensor. We characterized vacuum state, flow rate of separation of dissolved gases and oxygen concentration which were influenced by the manufactured vacuum pump.

## II. METHODS

Fig. 1 shows basic concept to separate dissolved gases from water. The material needs to be hydrophobic to repel water. More separation of dissolved gases from water needs porous material. Efficiency of separation depends on the surface area of the porous material. Larger surface area is needed for a human to breathe under water using dissolved gas including oxygen [5]. When an inset is drowned under water, he contains air trapped between furs. The liquid-gas interface formed around furs works as air supplier. Dissolved gases are passed through liquid-gas interface by diffusion and supplied to the insect. Carbon dioxide is exited into water. Large surface area for a human means large sphere shape with more than 5m diameter. The volume which occupies large space for the height of a human is needed to be reduced for an efficient portable device. So the hollow fiber type of membrane which has small volume for surface area is requested. Many hollow fiber membranes are requested to obtain high surface area, but have less volume than flat sheet membranes. Proper spaces between hollow fibers are needed to obtain contact time. It needs for fresh water which contains necessary oxygen to flow by surfaces of hollow fibers.

Fig. 2 shows the operation rate for inlet and outlet of a vacuum pump which separates dissolved gases from water. When a diaphragm goes down, dissolved gases are supplied from water through hollow fiber membranes. When a diaphragm goes upward, separated gases exit to outside or a storage tank. The rotation of axis of a motor is controlled by rpm speed.

The experimental system includes a vacuum pump,

membrane, a mass flow meter and an oxygen sensor. Fig. 3 shows overview of a manufactured vacuum pump. It is supplied by 24 V dc voltage and has two external ports. One is for inlet and the other is for outlet. The membrane has hollow fiber type which has large surface area per unit volume. Shell side of one is supplied by water with 6 L/min flow rate. Dissolved gases are separated from water through lumen side of one in Fig. 4.

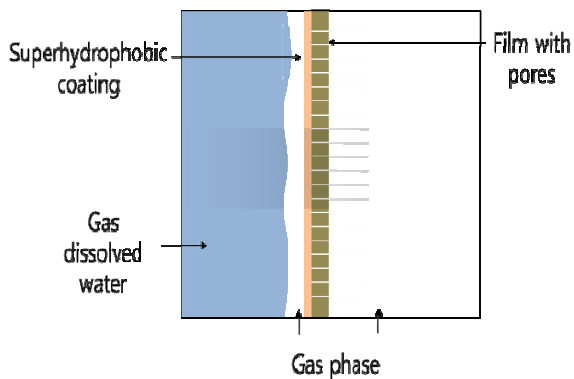
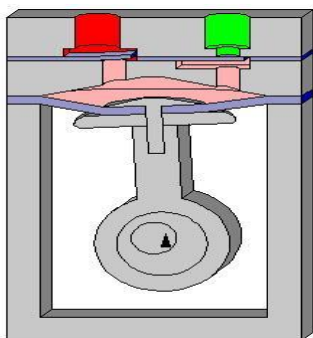
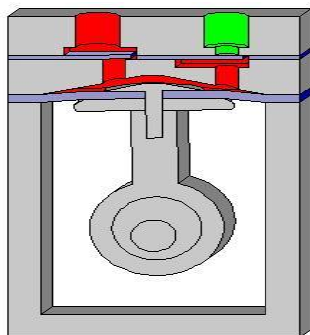

Fig. 1 Basic concept for separation of dissolved gases from water



(a) Inlet stat



(b) Outlet state

Fig. 2 Basic concept for inlet and outlet of supplied air



(a) External view



(b) Internal view

Fig. 3 Manufactured vacuum pump

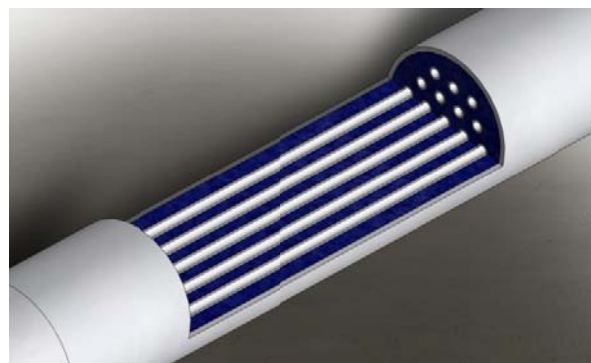

Fig. 4 Cross section view of a hollow fiber membrane

Table I shows the characteristics of a hollow fiber membrane made from Liqui-Cel Company. Mass flow meter and oxygen sensor are placed on the outlet of a vacuum pump. The mass flow meter (model 50K-7) is made from McMillan Company and has 1L/min of range. The oxygen sensor (SS2118) is supplied by Senko Company and has 0-30% of range.

TABLE I  
 POLYPROPYLENE HOLLOW FIBER CHARACTERISTICS

Name	Spec.
Material	Polypropylene
Potting materials	Epoxy
Surface area(m <sup>2</sup> )	8.1
Porosity (%)	~25
OD/ID (um)	300/200
Shell side volume(L)	1.26
Lumen side volume(L)	0.61
Height(mm)	512
Diameter(mm)	116.1

### III. RESULTS AND DISCUSSIONS

Fig. 5 shows the manufactured vacuum pump which is fully drowned to confirm water-proof characteristics as a portable device under water. Two batteries with 12V dc are serially connected and 24V dc is generated. As in Fig. 6, inside view test shows no water.

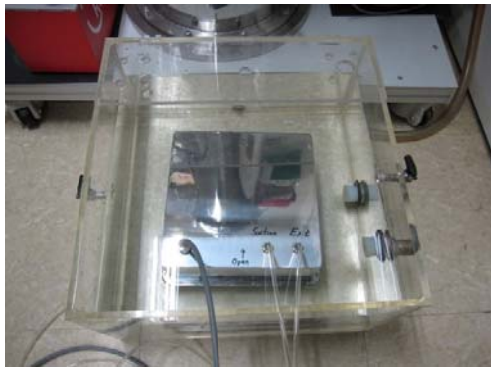

Fig. 5 Manufactured vacuum pump being tested underwater



(a) Left side view



(b) Right side view

Fig. 6 Inside view of manufactured vacuum pump after underwater test

We separated dissolved gases from water using a vacuum pump which could be supplied by dc voltage. DC motor has maximum 3000rpm. Experimental condition has 20%, 30%, and 40% of maximum rpm.

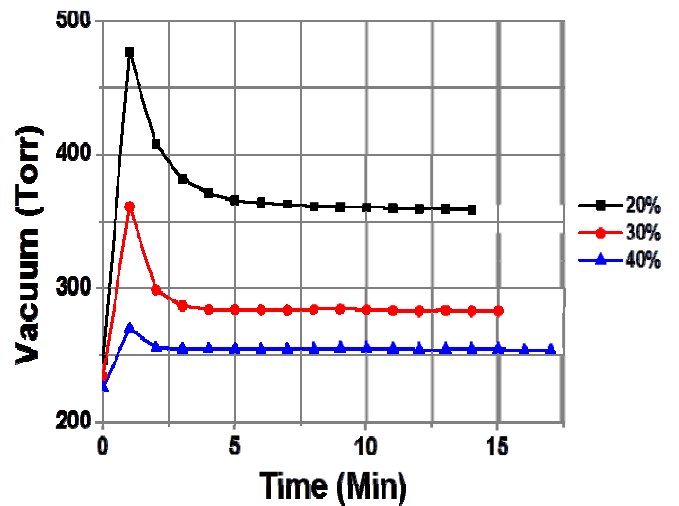

Fig. 7 The effects of rpm on vacuum state

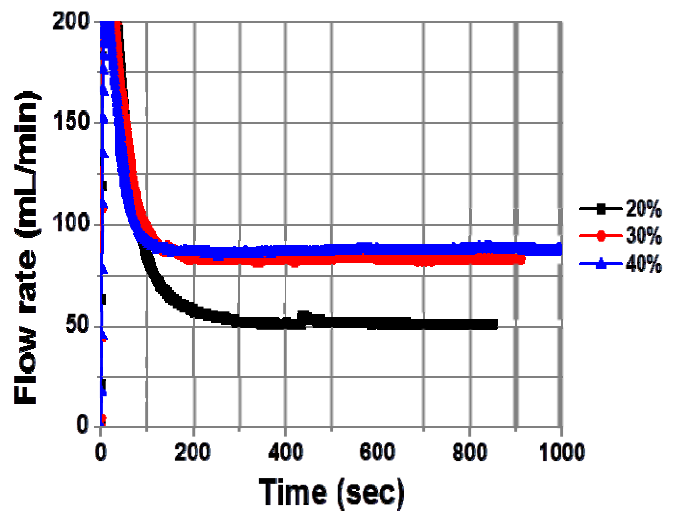

Fig. 8 The effects of rpm on flow rate

In Figs. 7 and 8, both vacuum and separation of dissolved gases from water are increased as rpm is increased. And concentration of oxygen separated from water is also increased in Fig. 8 as rpm is increased. 40% of rpm leads to about 250 Torr of vacuum, 87mL/min of flow rate and 29% of oxygen concentration. If water flow rate and surface area of membrane are increased, separation expects to be increased. It is reported that 1L/min of oxygen is needed for typical breathing of a human. These results can be used to develop a portable artificial gill using separation of dissolved oxygen from water.

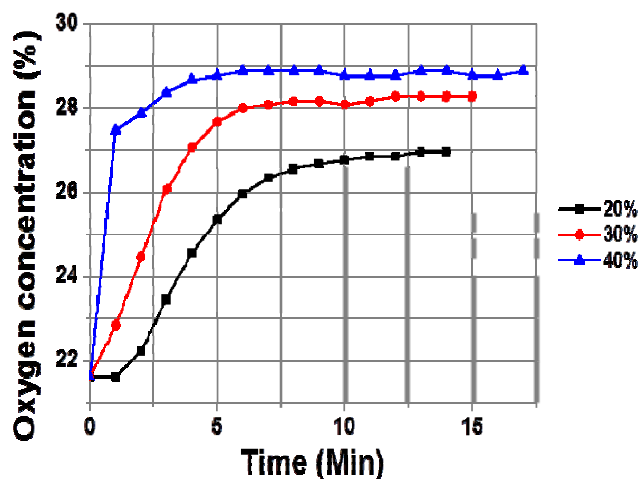

Fig. 9 The effects of rpm on oxygen concentration

#### IV. CONCLUSION

We investigated the amounts of dissolved gases separated from water using the dc battery driven vacuum pump. Experimental condition had 20%, 30%, and 40% of maximum rpm. 40% of rpm led to about 250 Torr of vacuum, 87 mL/min of flow rate and 29% of oxygen concentration. If water flow rate and surface area of membrane are increased, separation is expected to be increased. It was reported that 1L/min of oxygen was needed for general breathing of a human. These results can be used to develop the breathing device using dissolved oxygen under water.

#### REFERENCES

- [1] M. C. Yang and E. L. Cussler, "Artificial gills," *J. of Membrane Science* 42, 1989, pp. 273-284.
- [2] K. Nagase, F. Kohori, and K. Sakai, "Development of a compact gill using concentrated hemoglobin solution as the oxygen carrier," *J. of Membrane Science* 215, 2003, pp. 281-292.
- [3] K. Nagase, F. Kohori, K. Sakai, and H. Nishide, "The Rearrangement of hollow fibers for enhancing oxygen transfer in an artificial gill using oxygen carrier solution," *J. of Membrane Science* 249, 2005, pp. 235-243.
- [4] P. W. Heo and I. S. Park, "Separation of dissolved gas for breathing of a human against sudden waves using hollow fiber membranes," *WASET* 69, 2012, pp. 1258-1261.
- [5] N. J. Shirtcliffe, G. McHale, M. I. Newton, C. C. Perry, and F. B. Pyatt, "Intrinsically superhydrophobic organosilica sol-gel foams", *Langmuir* 19, 2003, pp. 5626-5631.