

Numerical Analysis of All-Optical Microwave Mixing and Bandpass Filtering in an RoF Link

S. Khosroabadi, M. R. Salehi

Abstract— In this paper, all-optical signal processors that perform both microwave mixing and bandpass filtering in a radio-over-fiber (RoF) link are presented. The key device is a Mach-Zehnder modulator (MZM) which performs all-optical microwave mixing. An up-converted microwave signal is obtained and other unwanted frequency components are suppressed at the end of the fiber span.

Keywords—Microwave mixing, bandpass filtering, all-optical, signal processing, MZM.

I. INTRODUCTION

RoF technologies are of great interest for many potential applications such as broad-band wireless access networks, sensor networks, radar and satellite communication systems. The key function of an RoF network is to distribute microwave and millimeter wave signals over optical fiber to take the advantages of the low loss, low dispersion, and large band width of optical fiber links. It is also highly desired that the distributed signals can be processed directly in the fiber link without optical to electrical (O/E) and electrical to optical (E/O) conversions. All-optical microwave mixing and filtering are proposed by many authors [1-6].

In this paper, an approach to perform both all-optical microwave mixing and bandpass filtering in an RoF link using a MZM is presented. The mixed signals at the output of the MZM are fed to the single mode fiber (SMF) link, which acts as a dispersive device for bandpass filtering, and distributes the mixed signal to a remote site. The combination of the MZM, of an array of tunable lasers, and of the SMF link forms an all-optical microwave bandpass filter, which can be designed to have a passband located at the up-or down-converted microwave frequency. Section II presents the configuration principle of the MZM that realize an all-optical mixing system in an RoF link without extra optical to electrical conversion. Section III presents the numerical results and an extension to achieve a bandpass filter operation. In this Section, a bandpass filter based on all-optical filtering using a SMF is demonstrated. A brief conclusion is given in Section IV.

M.R. Salehi is with Shiraz University of Technology, Shiraz, IRAN (corresponding author to provide phone: 98-711-7353500; fax: 98-711-7354514; e-mail: salehi@sutech.ac.ir).

S. Khosroabadi received the M.Sc. degree in electrical engineering from Shiraz University of Technology, Shiraz, IRAN (e-mail: s.khosroabadi@sutech.ac.ir).

II. SYSTEM PRINCIPLE

The schematic of the proposed signal processor with MZM is shown in Fig.1.

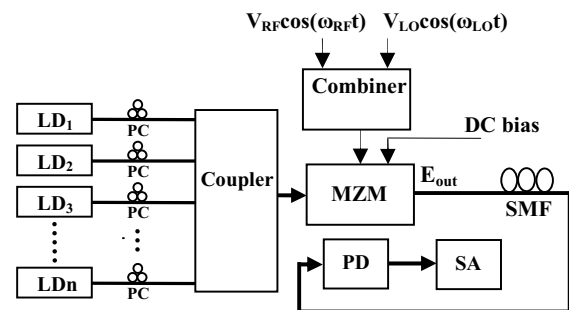

Fig.1 Schematic of the proposed system with MZM. LD: Laser diode, PD: Photodetector, SA: Spectrum analyzer

The mixed optical signals after the MZM are applied to the SMF link serving as a dispersive device as well as a transmission medium. By applying the optical signal to a PD, an electrical signal with different frequencies can be generated. The generated electrical signal V_{out} can be expressed as

$$\begin{aligned}
 V_{out} = & \left\{ -J(1, \beta_{RF}) \times J(1, \beta_{LO}) \times J(0, \beta_{RF}) \times J(0, \beta_{LO}) \right. \\
 & + J(0, \beta_{RF}) \times J(1, \beta_{LO}) \times J(1, \beta_{RF}) \times J(2, \beta_{LO}) \\
 & - J(2, \beta_{RF}) \times J(1, \beta_{LO}) \times J(1, \beta_{RF}) \times J(2, \beta_{LO}) \\
 & + J(1, \beta_{RF}) \times J(0, \beta_{LO}) \times J(2, \beta_{RF}) \times J(1, \beta_{LO}) \\
 & + J(0, \beta_{RF}) \times J(1, \beta_{LO}) \times J(1, \beta_{RF}) \times J(2, \beta_{LO}) \\
 & - J(2, \beta_{RF}) \times J(1, \beta_{LO}) \times J(1, \beta_{RF}) \times J(2, \beta_{LO}) \\
 & + J(1, \beta_{RF}) \times J(0, \beta_{LO}) \times J(2, \beta_{RF}) \times J(1, \beta_{LO}) \\
 & \left. - J(1, \beta_{RF}) \times J(1, \beta_{LO}) \times J(0, \beta_{RF}) \times J(0, \beta_{LO}) \right\} \\
 & \times \cos((\omega_{LO} + \omega_{RF})t + \phi_o) + \dots \quad (1)
 \end{aligned}$$

where $\phi_o = (\pi \cdot V_{DC}) / V_\pi$, and V_π is the half-wave voltage of the MZM. J_n is the Bessel function of the first kind of order n .

The generated signal distribution is affected by ϕ_o , which is determined by the dc bias V_{DC} .

III. NUMERICAL RESULTS

Fig.2 shows the spectra of the generated electrical signals with $\phi_o = \pi/2$.

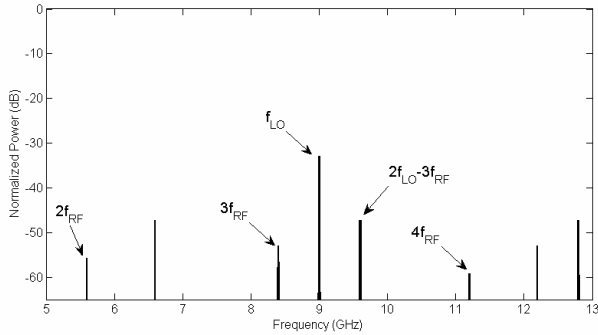

Fig.2. The generated electrical signal with $\phi_o = \pi / 2$

In Fig.2, it is shown that a series of microwave signals are obtained. Corresponding to Fig.2 if the direct current bias adjust to have $\phi_o = \pi/2$, the up-converted frequency suppress.

Therefore, this configuration can not be used with $\phi_o = \pi/2$ in practical situations for up-conversion.

The spectra of the generated electrical signals at the output of the mixer with $\phi_o = \pi, 2\pi$ is shown in Fig. 3.

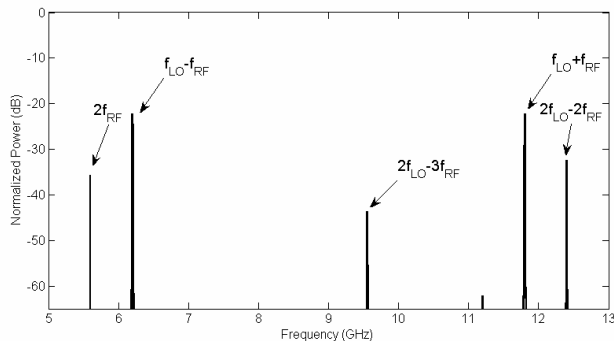

Fig.3. The generated electrical signal with $\phi_o = \pi, 2\pi$

Fig.3 shows that the generated signal frequencies are located at 5.6, 6.2, 9.6, 11.8 and 12.4 GHz which are the local and radio frequency and sum and subtract of them. It is clear that the up-converted component at 11.8 GHz is also obtained. Therefore, we should adjust the direct current bias to have $\phi_o = \pi$ or $\phi_o = 2\pi$ for up-conversion. In Fig.3, it is shown that a series of unwanted microwave signals which correspond to the different frequency components of the mixing are also observed. Therefore, a bandpass filter with narrow passband and high mainlobe-to-sidelobe ratio must be used to suppress the unwanted frequency components. Because the generated frequencies are very close together, the filter must be design with very narrow bandwidth.

If the passband peak of the microwave bandpass filter is located at the frequency of the up-converted component, the system can perform simultaneously all-optical microwave mixing and bandpass filtering. The passband of the transfer function of the filter which uses one laser is very wide and the up-converted signal can not be filtered. To achieve microwave filtering with very narrow bandwidth, the number of taps must be large. Many taps can be obtained using an array of LDs as the light source and sweeping the modulating frequency. The frequency response of the signal processor is shown in Fig.4.

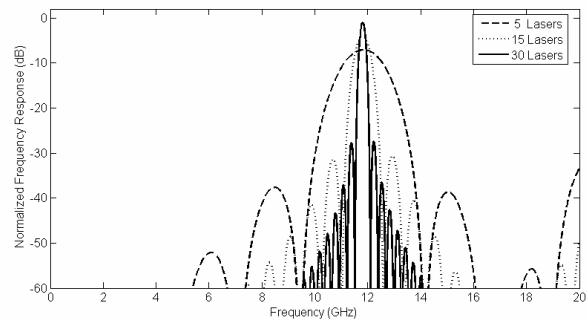

Fig.4 Transfer function of the filter with different LDs

It can be seen that a bandpass filter with narrow passband and high mainlobe-to-sidelobe ratio is obtained to suppress the unwanted frequency components. The RF frequency at the peak of the passband is of 11.8 GHz and is determined by the wavelength spacing of the LDs which is 0.2 nm and the accumulated dispersion of the 30 km SMF link. Fig.5 shows the spectra of the generated electrical signals over 30 km length of the SMF with $D=17$ ps/(nm.km).

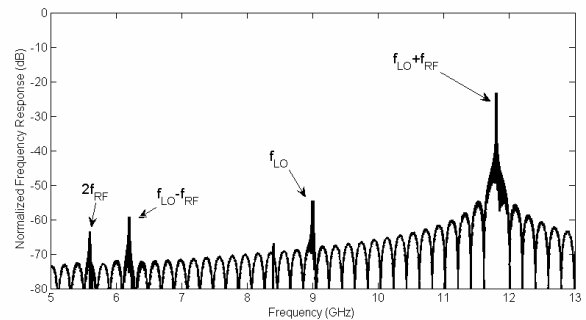

Fig.5. Power spectrum at the output of the PD

In Fig.5, it is shown that only the up-converted signal is obtained while other frequency components are efficiently suppressed.

IV. CONCLUSION

In this paper, an all-optical signal processing that performed

all-optical microwave mixing and bandpass filtering in an RoF link was presented. The all-optical microwave mixer device in signal processing was a MZM. A length of SMF can be used in the system as a dispersive device. Therefore, the up-converted microwave signal was generated at the end of the SMF. Numerical results show that the only up-converted signal was obtained at the remote site with a high rejection of other unwanted components.

REFERENCES

- [1] S. khosroabadi and M. R. Salehi, "Analysis of microwave photonic notch filter with tunable parameters," *IEEE Proc. Int. Conf. on Signal Processing*, Dubai 2007, pp. 860-863.
- [2] S. khosroabadi and M. R. Salehi, "Optical generation of tunable millimeter-wave signals using optical phase modulator and optical attenuator element," *ICEE2008 Conf. on Electrical and Electronic Engineering*, Published, 2008.
- [3] F. Zeng and J. Yao, "All-optical bandpass microwave filter based on an electro-optic phase modulator," *Opt. Express*, vol. 12, pp.3814–3819, 2004.
- [4] F. Zeng and J. Yao, "Investigation of phase-modulated-based all-optical bandpass microwave filter," *Journal of Lightwave Technology*, vol. 23, pp. 1721–1728, 2005.
- [5] G. K. Gopalakrishnan, W. K. Burns and C. H. Bulmer, "Microwave optical mixing in LiNbO3 modulators," *IEEE Trans. Microwave Theory Tech.*, 41, pp. 2383–2391, 1993.
- [6] J. Wang and J. Yao, "A Tunable Photonic Microwave Notch Filter Based on All-Optical Mixing," *IEEE Photonics Technol. Lett.*, vol. 18, 2006.