

# Study on the Production of Chromite Refractory Brick from Local Chromite Ore

Waing Waing Kay Khine Oo, Shwe Wut Hmon Aye, Kay Thi Lwin

**Abstract**—Chromite is one of the principal ore of chromium in which the metal exists as a complex oxide ( $\text{FeO} \cdot \text{Cr}_2\text{O}_3$ ). The prepared chromite can be widely used as refractory in high temperature applications. This study describes the use of local chromite ore as refractory material. To study the feasibility of local chromite, chemical analysis and refractoriness are firstly measured. To produce chromite refractory brick, it is pressed under a press of 400 tons, dried and fired at  $1580^\circ\text{C}$  for fifty two hours. Then, the standard properties such as cold crushing strength, apparent porosity, apparent specific gravity, bulk density and water absorption that the chromite brick should possess were measured. According to the results obtained, the brick made by local chromite ore was suitable for use as refractory brick.

**Keywords**—chemical analysis, chromite ore, chromite refractory brick, refractoriness.

## I. INTRODUCTION

REFRATORIES are the primary materials used by the metallurgical industry in the construction of all furnaces, in the internal linings of furnaces for melting, smelting in vessels for holding and transporting metal and slag, in furnaces for heating before further processing, and in the flues or stacks through which hot gases are conducted. The metallurgical processes require very high operating temperatures and then the refractory material became more essential because it can withstand very high temperature without rapid physical and chemical deterioration. Other important properties of refractories are chemical composition, bulk density, apparent porosity, apparent specific gravity and cold crushing strength at atmospheric temperatures. Refractories can be classified into three classes on the basis of chemical composition – namely acid, basic and neutral. Acid refractories are used in areas where slag and atmosphere are acidic, stable to acids but attacked by alkalis. Their main raw materials are high silica and fireclay. Basic refractories are used in areas where slag and atmosphere are basic, stable to alkaline materials but reacts with acids. Their main raw materials are magnesite and dolomite, chrome-magnesite and magnesite-chrome. Neutral refractories are used in areas where slag and atmosphere are neither basic nor acidic and are chemically stable to both acids and bases. The common examples of these materials are high alumina and chrome [1].

Waing Waing Kay Khine Oo, from Department of Metallurgical Engineering and Materials Science, Technological Research Department, Pyin Oo Lwin, Myanmar, phone: 00-95-9 5002619, email: ww.kaykhineoo@gmail.com.

Shwe Wut Hmon Aye, from Department of Metallurgical Engineering and Materials Science, Technological University (Hmawbi), Myanmar email: hmon152@gmail.com.

Kay Thi Lwin is Rector from Technological University (Thanlyin), Myanmar. email: dr.ktlwin@gmail.com.

A large number of raw materials for refractory uses is found in the earth's crust. In Myanmar, many naturally occurring raw materials are found for the production of refractory materials. Among them, chromite ore, one of the neutral refractories occurrences is widely spreaded and is associated with the likewise widely distributed ultra basic rocks. Chromite deposits can be found in Myanmar [2].

Among them, the two large deposits are Tagaung taung area which is situated in Thabeikgin township, Mandalay Division and Mwetaung area which is situated in Tee Tain township, Chin State. In Tagaung taung area, chromite ores contain 48%  $\text{Cr}_2\text{O}_3$  and 50%  $\text{Cr}_2\text{O}_3$  in Mwetaung area [3].

A typical analysis of chromite suitable for refractory purpose is 30-50%  $\text{Cr}_2\text{O}_3$ , 13-30%  $\text{Al}_2\text{O}_3$ , 12-16%  $\text{Fe}_2\text{O}_3$ , 14-20%  $\text{MgO}$ , 3-6%  $\text{SiO}_2$  and up to 1%  $\text{CaO}$ . The most attractive property of chromite is based on its high melting point of  $2180^\circ\text{C}$  ( $3960^\circ\text{F}$ ). Chrome-based refractories are typically used in ceramic production kilns, glass melting furnaces and lining of rotary kiln for manufacture of Portland cement [4].

In my research work, chromite ore obtained from Mwetaung area, Chin State in Union of Myanmar is used as the raw material. The characteristics and necessary properties required for use as refractory are studied. After that, the manufacturing of refractory brick is carried out. If high quality chromite refractory can be produced locally and commercially, we can substitute the imports, save the foreign currency and support the development of industrial sector.

## II. EXPERIMENTAL PROCEDURE

In Myanmar, there are so many regions that can produce for refractory purposes. Among them, naturally occurring chromite ore is one, and is used for testing in this study. To test the feasibility of the use of local chromite as refractory tests such as chemical analysis is firstly carried out. From this analysis, the amount of  $\text{Cr}_2\text{O}_3$ ,  $\text{Al}_2\text{O}_3$ ,  $\text{Fe}_2\text{O}_3$ ,  $\text{MgO}$ ,  $\text{SiO}_2$ ,  $\text{CaO}$  contained in the chromite ore have been determined.

The fusion and softening temperature of chromite ore was determined by Pyrometric Cone Equivalent (PCE) method. Approximately 2g of chromite powder is mixed with suitable amount of binder and made into a cone having dimensions as shown in Fig.1 by using a metallic mould. In this determination, different binders such as boric acid, magnesium chloride and sodium silicate were used. Before molding, a small amount of lubricant was applied to the inner layer of the mould for easy removal of the cone. Then, the mixed powder was put in the mould and the shape was formed by using a steel blade. After that, the cone was pushed out by the steel blade and put on a plate. These testing cones were heated in an oven at  $110^\circ\text{C}$  for one hour to remove moisture.

The equal ratio of china clay and pure alumina powder was mixed with suitable amount of water and was put in the crucible. A sheet of thin card board was laid between the crucible and the base material. The purpose was to prevent the base material from sticking to the crucible. The base was allowed to dry at 110°C for 12 hours before testing. The crucible can test only four cones at one time. Therefore, the cones mixed with different binders were tested and compared with Standard Seger cone according to the following arrangement.

(1) For first testing,

Three chromite cones with boric acid, sodium silicate and magnesium chloride used as binder, respectively, and one standard Seger cone (# 35)

(2) For second testing,

Three chromite cones with boric acid, sodium silicate and magnesium chloride used as binder, respectively, and one standard Seger cone (# 36)

(3) For third testing,

Three chromite cones with boric acid, sodium silicate and magnesium chloride used as binder, respectively, and one standard Seger cone (# 37)

The standard Seger cones used in this experiment were manufactured by the Japan Seger Cone Association and approved by Government Industrial Research Institute, Tokyo. The testing cones and the standard Seger cone were made to stand by embedding their lower ends by approximately 4 mm depth in the base material. Then, the crucible as shown in Fig.2 was placed on the crucible table of the kiln. A pressure regulator as shown in Fig. 3 was attached to the propane gas container, and connected to the rubber hose which leads to the burners. A pressure regulator was attached to the oxygen cylinder, and connected to the rubber hose which leads to the burners. Then, the opening/closing valves at the top of the propane and oxygen cylinders were opened fully. The pressure regulator screw of the propane gas was tightened so as to give a pressure of approximately 0.8 Kgf/cm<sup>2</sup>. The tip of the burner was made to face the outside of the kiln, and the propane gas control valve of the burner nozzle was opened a little and the burner was ignited. The pressure regulator screw of oxygen was tightened to give the pressure of approximately 4-4.2 Kgf/cm<sup>2</sup> and the oxygen control value of the burner was opened a little. The combustion was given under the condition where little oxygen mixed with propane gas. When the condition of the flame has been stabilized, the burner nozzle was adjusted so that the highest temperature portion of the flame touched the approximate center of the height of the crucible.

The propane gas pressure during heating was approximately 0.8 Kgf/cm<sup>2</sup> and the oxygen pressure was approximately 4-4.2 Kgf/cm<sup>2</sup>. These conditions were kept as uniform as possible. The temperature control was made by controlling the amount of gas. During heating, the condition in the kiln was observed with colored glass at every 5 minutes interval. When a cone started to deform, the oxygen pressure was immediately decreased a little and the temperature was reduced. Then, the variation of the cones was constantly observed.

When it was recognized that the tip of the testing cone has touched the base, the control valve of the propane gas and the control valve to the oxygen gas were immediately closed.

The burner nozzle was taken away quickly, and the opening/closing valves of the oxygen cylinder were closed. Next, the pressure regulator valves for the oxygen and the propane were loosened. Then, the remaining gas in the hose was removed by opening the control valves of the burners. After shutting down of the burners, the test crucible was left to cool, and it was taken out from the tester with tongs, and the deformation of the cones was observed [6].

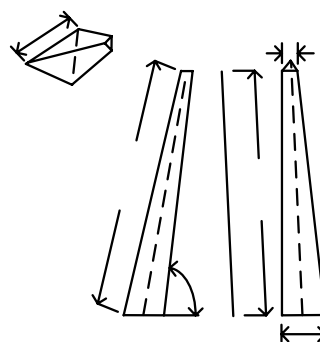

Fig. 1. Dimensions of a Pyrometric Cone

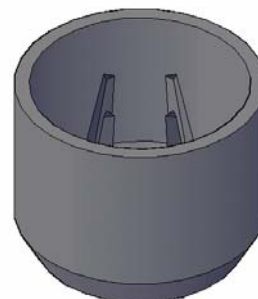
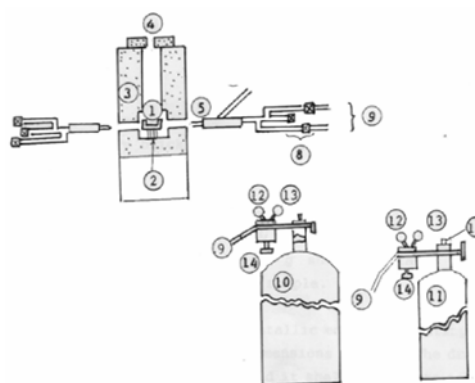

Fig. 2. Arrangement of Test Cones



- |                            |                         |
|----------------------------|-------------------------|
| (1) Crucible               | (2) Crucible Table      |
| (3) Kiln Body              | (4) Kiln Cover          |
| (5) Nozzle                 | (8) Control Valve       |
| (9) Rubber Hose            | (10) Propane Cylinder   |
| (11) Oxygen cylinder       | (12) Pressure Gauge     |
| (13) Pressure Gage         | (14) Pressure Regulator |
| (15) Opening/Closing Value |                         |

Fig. 3. Heating Process in Test of Refractoriness [5]

The steps for production of chromite refractory brick are as follow:

- (1) size reduction
- (2) coarse, fine and powder preparation
- (3) weighing and mixing
- (4) forming
- (5) drying
- (6) firing

Firstly, the chromite ores are crushed with an impact crusher and crushed raw materials are screened. Required raw materials such as coarse grain of 4 kg, fine grain of 4 kg and powder of 4 kg are weighed. Proper amount of binder is added to make mud material to form the brick. In this process, magnesium chloride with clean water (300 ml) is used as chemical binder. The material is mixed and kneaded for 10 minutes after adding the binder to obtain homogeneous mud material. The total weight of the brick was 11.3 kg. To produce chromite refractory brick, pressed under a press of 400 tons, dried and fired at 1580°C for fifty two hours. The dimensions and shape of chromite refractory brick are shown Table 1.and Figure 4, respectively.

TABLE I DIMENSIONS OF REFRACTORY BRICK

Dimensions (mm)			
A	B	C	D
103	96.4	198	200

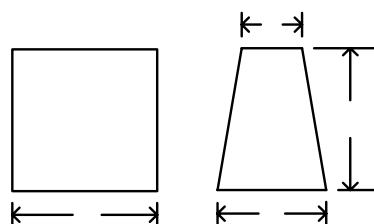
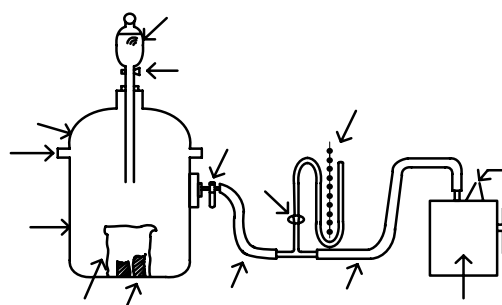

Fig. 4. Shape of Refractory Brick

The standard properties such as apparent porosity, apparent specific gravity, bulk density and water absorption that the chromite brick should possess were measured.



- |   |                               |
|---|-------------------------------|
| (1) Sample                              | (2) Beaker                    |
| (3) Vacuum Desiccator                   | (4) Cover of Desiccator       |
| (5) Contact Portion of Desiccator Cover | (6) Pressure Resistant Rubber |
| (7) Cock of Manometer                   | (8) Scale of Manometer        |
| (9) Vacuum Pump                         | (10) Cock for Oil Pouring     |
| (11) Oil (Kerosene)                     | (12) Cock                     |
| (13) Exhausting Port                    |                               |

Fig. 5. Vacuum Desiccator with Oil Pouring System [5]

A sample was cut off to a size of approximately 100×100×50 mm and dried in a dryer at 105-120°C till constant weight was obtained. It was weighed with a balance and taken as  $W_1$ .

The test piece for which  $W_1$  has been measured was put in the vacuum desiccator, and covered. On the contact surface of the desiccator cover grease was applied for air tightness. As shown in Fig.5, the cock of oil pouring was closed and the cock of manometer was opened and then the operation of the vacuum pump was started.

After that, suction for 15 minutes under the vacuum of 2.0 KPa (15mmHg) or under, the cock of manometer was closed and the oil was injected by opening the cock of oil pouring until the sample was soaked completely.

Then, the cock of oil pouring was closed and the cock of manometer was opened. The vacuum pump was turned off and the cock was opened to introduce the air gradually. Then, the desiccator was returned to the atmospheric pressure. After 30 minutes under the atmospheric pressure, the samples are left from the oil.

The test piece for which the oil saturation has been completed was hung in oil with a thin wire. It was weighed as  $W_2$ . The test piece, for which  $W_2$  has been measured, was taken out of oil, and then it was put on the weighing plate of the balance. It was weighed as  $W_3$  [6].

#### Calculation

To obtain accurate result, the mean value of the result was calculated from each two test pieces. The results are shown below.

- |                                 |                         |
|---------------------------------|-------------------------|
| For 1 <sup>st</sup> test piece, | $W_1 = 238.2 \text{ g}$ |
|                                 | $W_2 = 191.8 \text{ g}$ |
|                                 | $W_3 = 250.8 \text{ g}$ |
| For 2 <sup>nd</sup> test piece, | $W_1 = 219.8 \text{ g}$ |

$$W_2 = 194.9 \text{ g}$$

$$W_3 = 254.2 \text{ g}$$

In the following equation, the symbol "S" represents the gravity of kerosene.

$$S = 0.78$$

$$\text{For Apparent porosity (\%)} = \frac{W_3 - W_1}{W_3 - W_2} \times 100$$

$$\text{For Apparent porosity (\%)} = \frac{W_3 - W_1}{W_3 - W_2} \times 100$$

$$1^{\text{st}} \text{ test piece} = 21.4 \%$$

$$2^{\text{nd}} \text{ test piece} = 21.6 \%$$

The mean value is 21.5 %.

$$\text{For Water absorption (\%)} = \left( \frac{W_3 - W_1}{W_1} \times 100 \right) / S$$

$$1^{\text{st}} \text{ test piece} = 6.8 \%$$

$$2^{\text{nd}} \text{ test piece} = 6.9 \%$$

The mean value is 6.85 %.

$$\text{For apparent specific gravity} = \frac{W_1}{W_1 - W_2} \times S$$

$$1^{\text{st}} \text{ test piece} = 4$$

$$2^{\text{nd}} \text{ test piece} = 4.06$$

The mean value is 4.03.

$$\text{For bulk density} = \frac{W_1}{W_3 - W_2} \times S$$

$$1^{\text{st}} \text{ test piece} = 3.15 \text{ g/cm}^3$$

$$2^{\text{nd}} \text{ test piece} = 3.15 \text{ g/cm}^3$$

The mean value is 3.15 g/cm<sup>3</sup>.

To determine the Cold Crushing Strength of chromite refractory brick, the Amsler Typer crushing strength tester was used. In Fig. 6, the Amsler Type crushing strength tester was used. A sample was cut off to a size of approximately 100×50×50 mm.

The dimension of the pressure adding surface was measured with a unit of 0.5 mm for each test piece. The capacity of testing machine was adjusted that the load tested was found within 15-85 % off the capacity.

In testing, the pressure adding surface of the test piece was correctly placed in the center of the spherical seat. For the pressure adding speed, 10-15 Kg/cm<sup>2</sup> per second was made as standard and the maximum load W (Kgf) at the time when the test piece was obtained [6].

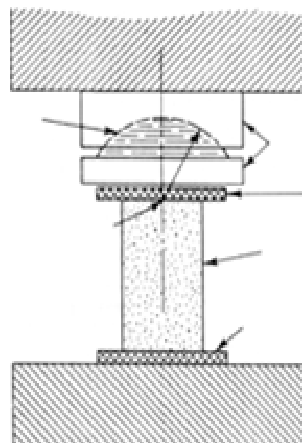

Fig. 6. Crushing Strength Tester [5]

#### Calculation

The mean value was calculated from two test pieces to obtain accurate results.

The results are shown below.

$$\text{For } 1^{\text{st}} \text{ test piece, } W = 34000 \text{ Kg}$$

$$a = 58.0 \text{ cm}$$

$$b = 58.4 \text{ cm}$$

$$\text{For } 2^{\text{nd}} \text{ test piece, } W = 31500 \text{ Kg}$$

$$a = 58.2 \text{ cm}$$

$$b = 58.0 \text{ cm}$$

$$\text{Cold crushing strength (Kgf/cm}^2\text{)} = \frac{W}{a \times b}, \text{ where}$$

W = Maximum Load (Kgf)

a, b = Lateral and side dimensions of the pressure adding surface (cm)

$$\text{For } 1^{\text{st}} \text{ test piece, Cold crushing strength} = \frac{3400}{58.0 \times 58.4}$$

$$= 1004 \text{ Kgf/cm}^2$$

$$\text{For } 2^{\text{nd}} \text{ test piece, Cold crushing strength} = \frac{31500}{58.2 \times 58.0}$$

$$= 933 \text{ Kgf/cm}^2$$

The mean value is 967 Kgf/cm<sup>2</sup>.

### III. RESULTS AND DISCUSSIONS

In Myanmar, a large number of naturally occurring raw materials have been found for the production of refractory materials. Among them, naturally occurring chromite ore is one, and is used for testing in this study. The raw material chromite ore is obtained from Mwetaung Area, Chin State. To test the feasibility of the use of local chromite as refractory tests such as chemical analysis and refractoriness were firstly carried out. The test results are given below and discussed

compared with the typical composition of chromite refractories.

#### Chemical Composition

The chemical composition of chromite ore is given below.

Chromic Oxide	49.98%
Iron Oxide	15.7%
Silica	4.68%
Alumina	12.14%
Magnesia	15.26%
Lime	ND

The typical chemical composition of chromite refractory is

Chromic Oxide	30 to 50%
Iron Oxide	12 to 16%
Silica	3 to 6%
Alumina	13 to 30%
Magnesia	14 to 20%
Lime	up to 1% [6]

By comparing these two compositions, it is obvious that the chemical composition of the local chromite ore is within the range of the standard composition. And so, it can be said that the chemical composition of chromite ore from Mwetaung area is suitable for use as refractory material.

#### Refractoriness

The refractoriness value shows the temperature at which the refractory material becomes soft and deformed. Table 2 shows the refractoriness of chromite with different binders.

According to the Pyrometric Cone Equivalent (PCE) test results, the chromite ore does not soften or deformed up to 1820°C. At that temperature we observed that the chrome cannot be fused.

The standard temperature of chromite brick is between 1700°C to 1900°C. Although the uses of different binders were studied, it can be seen from Table 2 that there was no distinct marked difference in refractoriness. From this, we can deduce that the three different binders can be used and the chromite ore has a fusion point of over 1825°C.

TABLE II REFRACTORINESS TEST RESULTS OF CHROMITE

No	Test Cone Material	Endpoints		
		# 35 (1770°C)	# 36 (1790°C)	# 37 (1825°C)
1	Chromite with boric acid binder	√	√	√
2	Chromite with sodium silicate binder	√	√	√
3	Chromite with magnesium chloride binder	√	√	√

#### Physical Properties of Chromite Brick

The standard properties such as apparent porosity, apparent specific gravity, bulk density and water absorption that the chromite brick should possess were measured.

The test results obtained from manufactured chromite brick are compared with the standard value of chromite brick which contains approximately 33 per cent of chromic oxide.

##### (i) Apparent Porosity

The apparent porosity of chromite brick is determined to be about 21.5% and the standard value is 14% by volume but varies greatly in brick from different sources. From this, the apparent porosity of chromite brick is more than the standard, this is seemingly because of non uniform size distribution and unhomogeneity. Lower porosity values give better resistance to slag attack and spalling resistance.

##### (ii) Apparent Specific Gravity

The apparent specific gravity of chromite brick is about 4.03 and the standard value is 3.8 to 4.0.

Apparent specific gravity is measured by immersion in a fluid which penetrates the open pores of the body, and thus refers to the solid refractory including closed pores. Lower specific gravity value indicates an excess of silica or insufficient burning of either the chrome ore or the bricks.

##### (iii) Bulk Density

The bulk density of chromite brick is about 3.15 and the standard value is greater than 2.1. An increase in bulk density of a given refractory increases its volume stability, heat capacity and resistance to slag penetration.

##### (iv) Water Absorption

The water absorption of chromite brick is 6.85%. The standard value is about 7 (unit). The test result values are nearly the same as the standard value.

#### Mechanical Property of Chromite Brick

##### (i) Cold Crushing Strength

The results obtained from cold crushing strength test give a value of 967 Kgf/cm<sup>2</sup> and the standard is 400 Kgf/cm<sup>2</sup>. The standard value is for Seger Cone No. 36, whereas the test result is for Seger Cone values greater than 37.

High cold crushing strength indicates good resistance to abrasion and more resistant to impact from bars, or during removal of slag.

#### IV. CONCLUSION

In this research, chromite ore obtained from Mwetaung area, ChinState in Union of Myanmar was tested as the raw material. This chromite ore was studied in the form of refractory brick. The characteristics and necessary properties required for use as refractory were studied.

The chemical composition of the local chromite ore is within the range of the standard composition. According to the refractoriness value, the chromite ore does not soften or deformed up to 1820°C. The apparent porosity value is about 21.5%. The apparent specific gravity value is about 4.03.

The bulk density value is about 3.15. The water absorption of chromite brick is 6.85%. The cold crushing strength value is 967 Kg/cm<sup>2</sup>. By comparing with the standard values, the manufactured chromite brick can be used as refractory material.

But there are some limitations and difficulties can be found. Because of limited testing facilities, some necessary experiments could not be carried out. For refractory purposes, it was necessary to measure and determine a lot of chemical and physical properties. Determination of service and physical properties such as load-bearing capacity, abrasion resistance, spalling resistance, thermal conductivity and electrical conductivity are needed. But, these tests could not be carried out because of inadequate measuring instruments and materials. However, various possible attempts were made to test the feasibility of production of chromite brick.

#### REFERENCES

- [1] Schumann, JR. Reinhardt. 1943, Metallurgical Engineering, Volume 5, Engineering Principles.
- [2] Felix Singer, Sonia S. Singer., "Industrial Ceramics"
- [3] Norton, F.H. "Refractories", 3<sup>rd</sup> ed., Mc Graw-Hill Book Company, New York, 1949.
- [4] MIS Myanma Ceramic Industrie, "Refractories Bricks Manufacturing Plant, Quality Control Manuals", 2001.
- [5] Kenich Sakurai. "Refractories", Nagoya International Training Center Japan International Cooperation Agency.
- [6] Norton, F.H. "Refractories", 3<sup>rd</sup> ed., Mc Graw-Hill Book Company, New York, 1949.