

# Torque Based Selection of ANN for Fault Diagnosis of Wound Rotor Asynchronous Motor-Converter Association

Djalal Eddine Khodja<sup>(1)</sup>, Boukhemis Chetate<sup>(2)</sup>

<sup>(1)</sup>Faculty of Sciences and Engineering Sciences, University Muhamed Boudiaf of M'sila  
B.P N° 116 Ichebilila (28000), Algeria, Tel/Fax: +213 35 55 18 36,  
E-mail: djalal\_ed@yahoo.fr

<sup>(1)(2)</sup>Research laboratory on the Electrification of industrial enterprises, University of Boumerdès,  
Avenue de l'indépendance, Boumerdès (35000), Algeria, Tel/fax : 213 24 81 70 50,  
Email : bchatat@umbb.dz

**Abstract**—In this paper, an automatic system of diagnosis was developed to detect and locate in real time the defects of the wound rotor asynchronous machine associated to electronic converter. For this purpose, we have treated the signals of the measured parameters (current and speed) to use them firstly, as indicating variables of the machine defects under study and, secondly, as inputs to the Artificial Neuron Network (ANN) for their classification in order to detect the defect type in progress. Once a defect is detected, the interpretation system of information will give the type of the defect and its place of appearance.

**Keywords**—Artificial Neuron Networks (ANN), Effective Value (RMS), Experimental results, Failure detection Indicating values, Motor-converter unit.

## I. INTRODUCTION

THE electric drives use more and more the asynchronous motors because of their robustness, specific power and low construction cost. However, it happens that these machines present electric or mechanical defects. Our objective is to detect these failures during their appearance and evolution [1, 2]. The three-phase asynchronous motor is now largely used in applications requiring a variable speed. It can use scalar or vector controls. These machines have the reputation of being robust and to be adapted to applications of high power. However, in spite of evoked qualities, it is not rare that these motors present some failures emanating of a premature ageing. The malfunctions of the asynchronous machine can be modelled mathematically, the total model being able to be obtained with simplifying assumptions. However, when this machine is associated with an electronic converter, the total model is valid only around the operating point [3, 4]. The experimental study of the behaviour of motor-converter association will give us the exact values of the parameters, thing which will make it possible to provide exact indicating values. For this purpose, we have carried out an experimental study of the defects of the wound rotor asynchronous machine associated to a SIMOVERT-SIEMENS electronic converter.

Djalal-eddine Khodja is with the Faculty of Sciences and Engineering Sciences, University Muhamed Boudiaf of M'sila, B.P N° 116 Ichebilila (28000), Algeria, Tel/Fax: +213 35 55 18 36, E-mail: djalal\_ed@yahoo.fr And with Research laboratory on the Electrification of industrial enterprises, University of Boumerdès Avenue de l'indépendance, Boumerdès (35000), Algeria, Tel/fax : 213 24 81 70 50,

This last is provided with a system of control which makes it possible to control the machine with several types of controllers and to carry out its diagnosis in the event of defect presence or if a bad parameterization is introduced. Then, after the study of the internal architecture of this converter, we proposed an architecture of a diagnosis system of this association provided with an interpretation system of information by the use of the artificial neuron networks.

## II. DIAGNOSTIC PROBLEMS

To avoid solving an opposite problem of diagnosis badly posed, it is essential to be based on relations of purpose cause. In general, the problem of the diagnosis returns primarily to a problem of knowledge on the deterministic model between the cause and the effect; more precisely it is necessary to find the deterministic variables of the defects, then to choose the signatures which “characterize” better these defects by the signal processing of these variables. For that, there are several diagnosis methods and their applications primarily depend on the nature of the problem to be solved [1, 4].

In addition, the highly strategic concept of predictive maintenance which pushed researchers to contribute to it variously requires the knowledge of the significant variables being measured to have a close idea of the state of the machine. The follow-up system of the machine should be able [5, 6, 7]:

- To interfere the least possible with the system (can the variables be measured “on line”?, problem of safety, etc);
- To be able to follow several variables;
- To be evolutionary;
- To be remote controllable;
- To store the data to allow a trend analysis.

As for the adopted strategy, it consists [6, 8, 9, 10, 11, 12]:

- To count the defects and the breakdowns being able to occur;
- To find the measurable variables related to these defects (indicating variables);
- To choose the nearest method of the criteria defined above;
- To define the thresholds “of alarm” from which it will be necessary to intervene.

Indeed, the problem to be solved in term of diagnosis has contributed to the choice of the diagnosis methods of the industrial processes and their implementation in the diagnosis system.

For this purpose, we have examined a starting (from 0 to 1 pu), an initiation of flux then the answer with a disturbance of exerted load from 13 to 16 (sec.). We noticed that when the application of the level of load generates an influence on speed (see figure.3). This last decreases slightly and it restores after a short time (a time which is equal to that of the starting of the machine).

### III. EVOLUTION OF THE PARAMETERS OF THE CONVERTER –MOTOR UNIT CONTROL

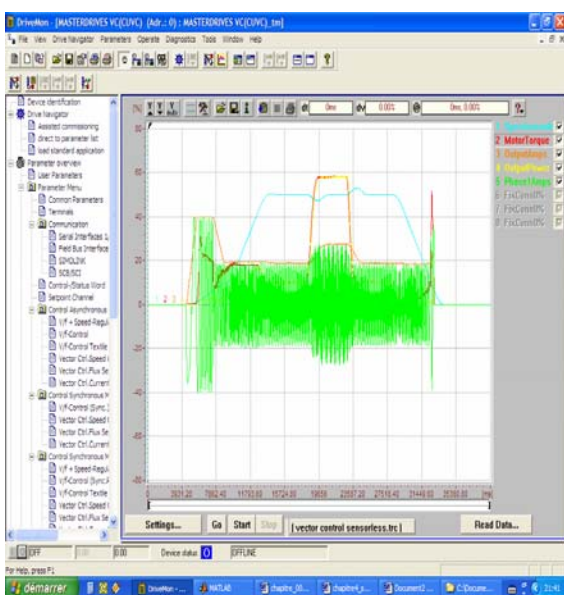

Fig. 1 Presentation of the experimental results of the machine under study by the MASTERDRIVE software of SIMOVERT Converter

The simovert masterdrive software enabled us to show the behaviour of the machine to validate the applied control (vector control by orientation of rotor flux without velocity pick-up) to the converter-motor unit (see figure 2).

For this purpose, we have examined a starting (from 0 to 1 pu), an initiation of flux then the answer with a disturbance of exerted load from 13 to 16 (sec.). We noticed that when the application of the level of load generates an influence on speed (see figure.3). This last decreases slightly and it restores after a short time (a time which is equal to that of the starting of the machine).

### IV. EXPERIMENTAL STUDY OF THE ASYNCHRONOUS MACHINE IN THE PRESENCE OF DEFECTS

The defects under study in this part, relate to the defects of voltage such as the cut and the imbalance of the phases as well as the rotor defects; such as: cut of one or two rotor phases. The considered defects are classified as follows:

- 1 - Single-phase cut of the supply voltage;
- 2 - Two-phase cut of the supply voltage;
- 3 - Cut of a rotor phase unloaded;
- 4 - Cut of a rotor phase in load;
- 5 - Cut of two rotor phases unloaded;
- 6 - Cut of two rotor phases in load.

In fact, all the characteristics of these defects (see fig.4 and fig.5) were taken in the following way: each defect was applied after the flow of the transient state (after starting) then it will be eliminated after a sufficient time after its appearance. The duration of each measurement is 15 seconds. In addition, the characteristics of these defects can be stored in numerical forms so that one can use them as signatures of references to work out the diagnosis system of the asynchronous machine.

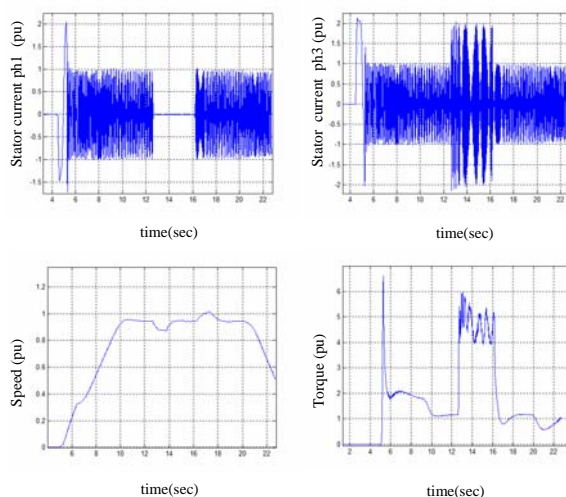

Fig. 2 Defect in the stator part in the case of a single-phase cut of the voltage in the inverter output

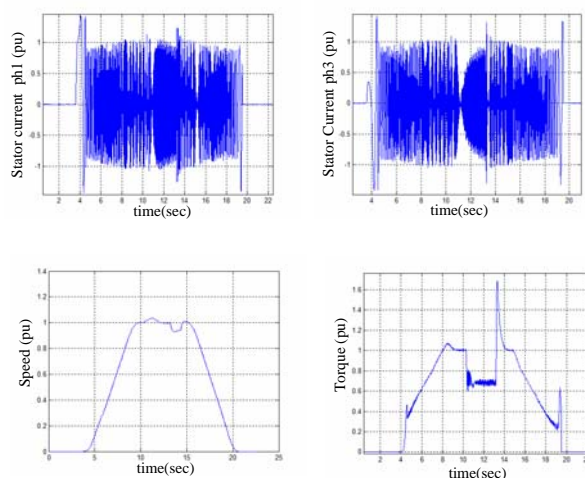

Fig. 3 Defect in the rotor part in the case of cut of a rotor phase in load

### V. INTERPRETATION OF THE SIMULATION RESULTS (NORMAL AND ABNORMAL MODE)

Using Simovert MasterDrive software, one could study the behaviour of the three-phase wound rotor asynchronous motor in the normal and abnormal modes. For this purpose, the curves of evolution of the various parameters representing the various quoted known modes were obtained. The results are presented in (Fig.2 et Fig.3). These last represent the curves of evolution of the various variables: the stator current and its effective value, speed, the developed power and torque.

The character of the graphs shows that in launching phase, the motor undergoes a lengthening of the transient state. As example, let us consider the electromagnetic torque: the evolution of this last is characterized at the beginning by a series of high amplitude oscillations of diminishing as the motor accelerates. At the end of the mode of starting, the torque reaches its maximum value, while approaching the value of the load (resistive torque), and the speed of the engine reaches its permanent value (established mode).

In the abnormal modes, the electric quantities are characterized in terms of the normal mode by an abrupt variation at the time of appearance of the defect. In our case, the defect is created when the motor is in established mode.

### VI. STRATEGY ADOPTED FOR IDENTIFICATION OF THE DEFECTS

Before the ANN block construction system for the failure detection of the electromechanical systems (identification of the acquired signals), one must first of all reach the phase of data acquisition (training bases) from which the ANN will be able to learn. This one can be always put in the form of file or of table. To build a nonparametric model (ANN) describing the behaviour of the electromechanical system (normal and abnormal operations), one must build a data base as detailed as possible. The training base the ANN is put in the form of file or table (matrix). This last is represented by vector classes, where each class represents an operation type, and each vector is represented by the effective values. In this case each vector is consisted of the 7 parameters as quoted above ( $I_a, I_b, I_c, V_a, V_b, V_c$  and  $W$ ). The latter represent the ANN input layer. In fact, to pass to the classification stage, we dispose for each parameter, 7 operating types, including normal operation (see table 1) [17, 18, 19, 20].

TABLE.I  
 DEFECT CLASSIFICATION

Category	Defect Type	Symbol
0	Without defect	NF
1	Single phase cut	CMS
2	Two phase cut	CBS
3	Rotor phase cut	CMR
4	Rotor two phase cut	CBR

The neuron network: its inputs are the effective values ( $I_a, I_b, I_c, V_a, V_b, V_c$  and  $W$ ), which means that the number of inputs of this network is equal to 7 (see figure.4). In addition, a standardization will be carried out to bring back all the values of the inputs in the interval [0,1]; this operation is carried out to adapt the effective values to the input neurons.

Indeed, each effective value is connected to an network input neuron which accepts only values ranging between zero and one (see Tab.2) [6, 20, 21, 22, 23, 24]. We decided to associate a code to each defect, i.e. each defect is represented by the four output neuronst. Each defect is represented in various forms (vectors). These vectors represent a class; in a clearer way, we have associated a code to each class. During the detection of a defect, the network must indicate an unspecified binary number (for example 010) to its output, which corresponds to this type of defect (two stator phases defect cut).

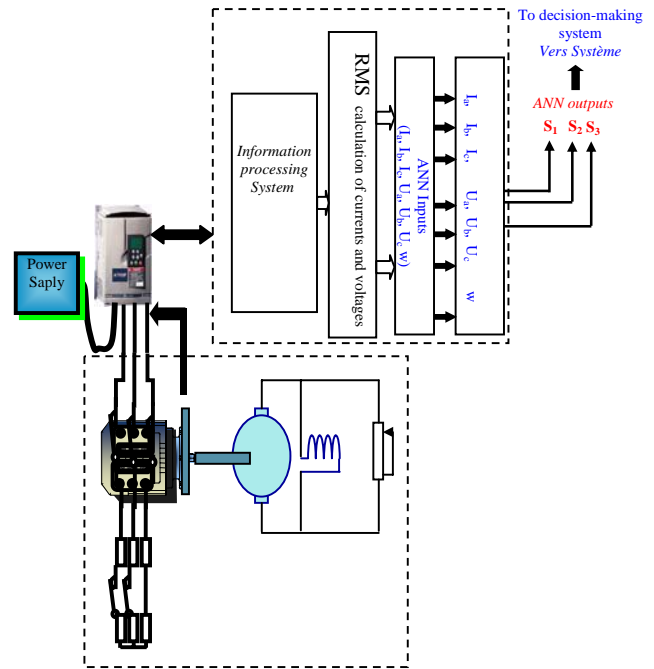

Fig. 4 Development of the defect automatic diagnosis system architecture of the asynchronous machine for an experimental realization

I.e. each output network must have only one figure either 1 or 0. The defects are represented in tableau.II; with their associated symbols and codes. The number of outputs for each network is equal to 3 [16, 17, 18].

TABLE.II  
 ANN TRAINING DATA BASE

Code	defects/stator			defects /rotor			unloaded / loaded (condition)	S <sub>3</sub>	S <sub>2</sub>	S <sub>1</sub>
	Ph1	ph2	ph3	ph1	ph2	ph3				
NF	1	1	1	1	1	1	0/1	0	0	0
CMS	0	1	1	1	1	1	0/1	0	0	1
CMS	1	0	1	1	1	1	0/1	0	0	1
CMS	1	1	0	1	1	1	0/1	0	0	1
CBS	0	0	1	1	1	1	0/1	0	1	0
CBS	0	1	0	1	1	1	0/1	0	1	0
CBS	1	0	0	1	1	1	0/1	0	1	0
CMR	1	1	1	0	1	1	0/1	0	1	1
CMR	1	1	1	1	0	1	0/1	0	1	1
CMR	1	1	1	1	1	0	0/1	0	1	1
CBR	1	1	1	0	0	1	0/1	1	0	0
CBR	1	1	1	1	0	0	0/1	1	0	0
CBR	1	1	1	0	1	0	0/1	1	0	0

### VII. TRAINAING OF THE SELECTED ANN

The network used is a multi layer network, an input layer which corresponds to the retina, an output layer which corresponds to the decision, and a certain number of layers known as hidden. These hidden layers constitute the variables of internal representation of the problems [6, 21, 22, 23, 24].

The selected network is trained by the retro propagation algorithm. The retro propagation is the most used paradigm of the ANN. The term refers to an algorithm to adjust the weights in a multi layer ANN, this paradigm was applied successfully in various fields such as military, medical, synthesis speech, signal processing, etc The retro propagation is based on mathematical principles. This method gave good results in

many applications. To apply it, it is enough to have input and output data.

### VIII. INTERPRETATION OF THE RESULTS

From the representation on line of the ANN inputs, we notice that the graphs change their characteristics at the moment of the application of the defect. In our case the defect is created at the moment  $t = 13s$ . At this moment, for example, inputs: S3, S2, S1, indicate respectively the values: 0, 1, 0, therefore the defect corresponding is: cut of a stator phase (See figure 5 ). The other applied defect, gave the same values as the desired values where the code of the defects: (the cut of two rotor phases, is S3, S2, S1) it corresponds to 1, 0, 0 (see Figure 6).

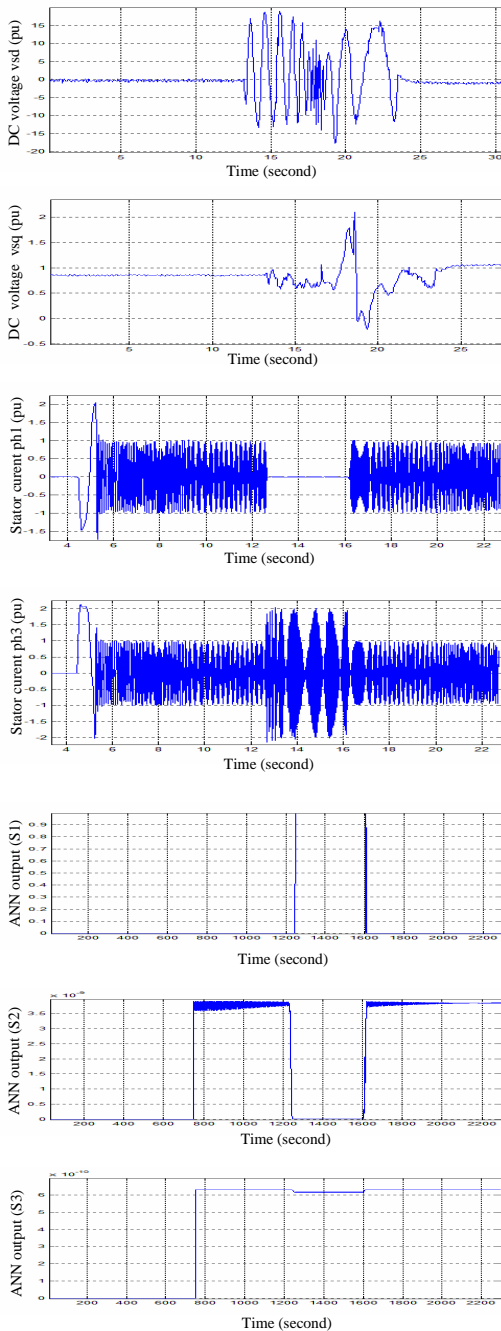

Fig. 5 ANN test performance, cut of an unloaded stator phase

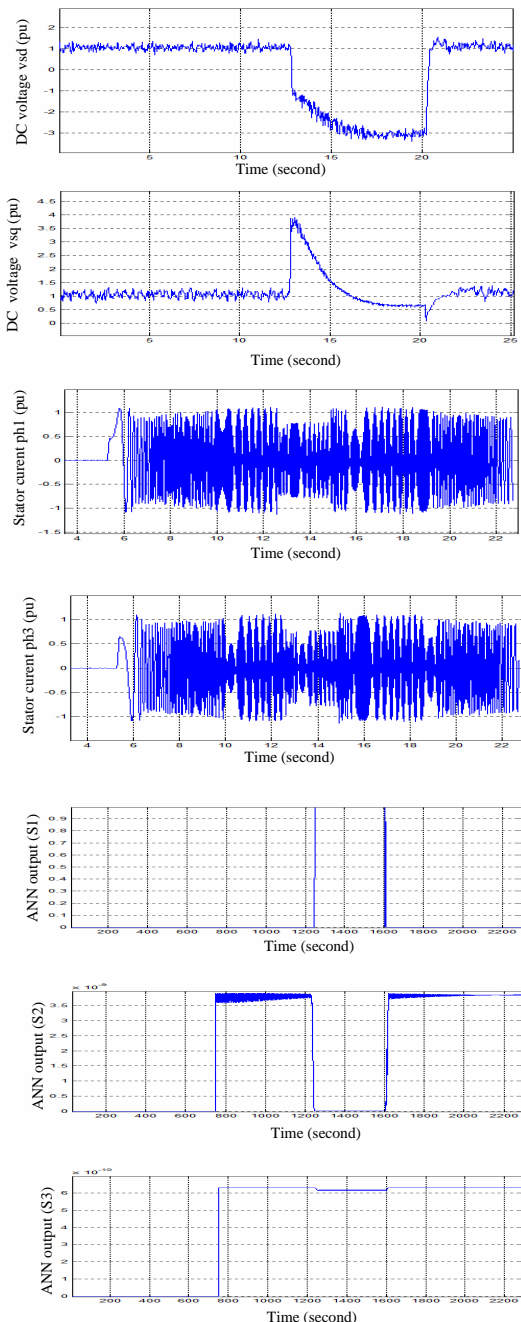

Fig. 6 ANN Test performance, cut of loaded two phase rotor

### IX. CONCLUSION

An experimental study of the defects of the wound rotor asynchronous machine was carried out. Using the Simovert MasterDrive software, we could obtain the curves of the various parameters of the machine during normal operation and in the event of presence of the defects. The same software makes it possible to obtain the values of the indicating variable in real time, thing which allows us after having stored the values of reference to diagnose the defects of the asynchronous machine in real time. For this purpose, the automatic diagnosis system architecture of the electromechanical system is proposed. The latter is provided

with a decision-making system which will allow, on one hand, to detect the defects by the artificial neuron networks and, on the other hand, the interpretation of these defects in order to deliver a diagnosis protocol which gives the description of the defects, their localizations and their remedies. The early failure diagnosis, takes place in two stages: in the first phase, one carries out the detection of a situation of anomaly, then one identifies the cause of the failure and one locates his place. Indeed, after the presentation of the automatic diagnosis system, in order to work out the interpretation module of information, we studied the network of neurons which has inputs easily accessible such as the effective values from the three stator currents and those of the supply voltage and as well as the instantaneous value speed. In addition, for the implementation of the interpretation subsystem of information with neuron networks, several parametric studies were carried out (choice of the network type, choice of the inputs, choice of the outputs, etc). These studies were preceded by the operation of the data acquisition, the purpose of which is to establish the base of ANN training in order to define during the training phase the number of hidden layers and numbers of neurons by hidden layer (dimensioning of the network final architecture). Lastly, the obtained results in the phase of test of the two networks enabled us to select the ANN to implement it in the automatic diagnosis system. The choice of this last is justified by its simplicity, because the of the neuron network inputs come directly from the current and voltage sensors, and the rotation speed (i.e., effective values of the currents and the voltages and the directly measured value of the rotation speed).

#### REFERENCES

- [1] F.Felippetti, G.francescini,C.Tassoni, S.zond, P.vas ; «AI Techniques in induction machines diagnosis including the speed ripple Effect », IEEE Transaction on industries applications, vol.34, n°1,junuary /February 1998,PP.98-108.
- [2] S.Nandi, H.A.Tolyat, « Condition monitoring and fault diagnosis of electrical machines : A review », Industry applications conference, thirty-fourth IAS annual meeting conference record of the 1999 IEEE,vol.1 ,PP.197-202.
- [3] G.Rostaing, « Diagnostic de défauts dans les entraînements électriques », Thèse de Doctorat, laboratoire d'électrotechnique de Grenoble, 1997/ sous la Direction de J.C.Trigeassou.
- [4] A.Murry, J.Penman, «Extracting usefull higher order features for condition monitoring using artificial neural network», IEEE transaction on signal processing, Vol, 45, N°11, November 1997, PP. 2821-2828.
- [5] A.R.Sadeghian, Z.Ye, B.Wu, «Induction motor mechanical fault on-line Diagnostic with the application of neural networks», IEEE Proceeding 2001, PP. 1015-1020.
- [6] G.Zwinnelsten, « Diagnostic des défaillances: théorie et pratique pour les systèmes industriels », Ed. Hermès Paris. 1995.
- [7] G. Didier and H. Razik, «Sur la détection d'un défaut au rotor des moteurs asynchrones», revue 3EI no27, December 2001, pp. 53-62. ISSN :1252-770X.
- [8] J.N. Chatain ; « Diagnostic par système expert », Ed, Hermès, Paris 1993.
- [9] B.Dubuisson ; « Détection et diagnostic des pannes sur processus », Technique de l'ingénieur. R7597,1992.
- [10] J.Morel ; « Vibrations des machines et diagnostic de leur état mécanique », Ed. Eyrolles, 1996.
- [11] J.Richalet, « Modélisation et identification des processus », Technique de l'ingénieur R7140, Avril 1987.
- [12] R.Casimir, «Diagnostic des défauts des machines asynchrones par reconnaissance des formes», Thèse de doctorat, l'école doctorale d'électronique, d'électrotechnique et d'automatique de Lyon, Décembre 2003.
- [13] Siemens 'Manuel', «Vector Control 'conpodium» , Simovert-Masterdrive 1998. Edition AF order no : 6SE7D87-6QX60.
- [14] B.Chetate, DJ.Khodja, « Diagnostic en temps réel des défaillances d'un ensemble Moteur asynchrone-convertisseur électronique en utilisant les réseaux de neurones artificiels », Journal Electrotechnika, Moscou 12/2003, pp:16-20.
- [15] DJ.Khodja, B.Chetate, «ANN system for identification and localisation of faillures of anatomawed electric asynchronous drives», 2<sup>nd</sup> International Symposium on Electrical, Electronic and Computer engineering en Exhibition, March, 11-13, NEU-CEE 2004, NICOSIA, TRNC pp : 156-161.
- [16] DJ.Khodja, B.Chetate, «Development of Neural Network module for fault identification in Asynchronous machine using various types of reference signals», 2<sup>nd</sup> International Conference PHYSICS and CONTROL, August,24-26, Physcon 2005, S' Ptersburg, Russia. pp : 537-542.
- [17] M.E.Hawary ; « Detection and localization of shorted turns in the DC field winding of turbine-generator rotors using novelty detection and fuzzified neural networks », Electronic Power Applications of Fuzzy Systems, Ed IEEE press, 1998, PP.85-111.
- [18] N.Kandil, V.K.Sood, K.Khorasani, RV.Patel ; « Fault identification in AN AC-DC transmission using neural networks », IEEE .Transaction on power systems, May 1992, Vol.7 .n°2, 1992, PP.812-819.
- [19] F.Filippetti, G.Franceschini, C.Tassoni ; « Neural Networks approach to electric machine on-line diagnostics ». EPE BRIGHTON 93, pp.213-218.
- [20] V.I.Komachinski, D.A.Omirnov, «Réseaux de Neurones et leurs utilisations dans les systèmes de commande et de connexion», Ed, Ligne Chaude, telecom, Moscou, 2002.
- [21] V.A.Tolovka. « Réseaux de neurones : Apprentissage, Organisation et Utilisation », Ed, Entreprise de rédaction de journal 'Radiotekhnika' Moscou, 2001.
- [22] T.Sorsa, HN.Koivo, « Neural networks in process fault diagnosis », IEEE transaction on systems , vol. 21,n° 4, july-august 1991.pp.815-825.
- [23] M.J.Boeck ; «Experiments in the application of Neural Networks to Rotating machine fault diagnosis», IEEE Intern. Juin conf on neural network, vol.1, 1992, pp.769-774.