

# Investigation of Heat Loss in Ethanol-Water Distillation Column with Direct Vapour Recompression Heat Pump

Christopher C. Enweremadu and Hilary L. Rutto

**Abstract**—Vapour recompression system has been used to enhance reduction in energy consumption and improvement in energy effectiveness of distillation columns. However, the effects of certain parameters have not been taken into consideration. One of such parameters is the column heat loss which has either been assumed to be a certain percent of reboiler heat transfer or negligible. The purpose of this study was to evaluate the heat loss from an ethanol-water vapour recompression distillation column with pressure increase across the compressor (VRC<sub>AS</sub>) and compare the results obtained and its effect on some parameters in similar system (VRC<sub>CS</sub>) where the column heat loss has been assumed or neglected. Results show that the heat loss evaluated was higher when compared with that obtained for the column VRC<sub>CS</sub>. The results also showed that increase in heat loss could have significant effect on the total energy consumption, reboiler heat transfer, the number of trays and energy effectiveness of the column.

**Keywords**—Compressor, distillation column, heat loss, vapour recompression.

## I. INTRODUCTION

IN the last few years, a growing importance of ethanol in the area of liquid fuels has been observed [1]. This importance is strengthened by concerns over prices and availability of crude oil as well as greenhouse gas emissions which have stimulated interest in alternatives to crude oil to provide for automotive power. Production of fuel ethanol from lignocellulosic materials has the potential to reduce world dependence on petroleum while decreasing net emissions of carbon dioxide, the principal greenhouse gas. The production of ethanol from primary agricultural products is often not cost effective as these materials find several applications in food and pharmaceutical industries, which makes it expensive. To speed up the substitution of petroleum with bioethanol, it must be made at competitive costs by the use of energy efficient processes; otherwise, there will be no market for it even though it is made from renewable resources.

The economic competitiveness of the ethanol production process strongly depends on the amount of used heat and

power. To increase the economic efficiency of ethanol as liquid fuel compared to the fuel production from crude oil, a number of optimization steps have been proposed concerning the purification of ethanol, because essentially concentration and dewatering of ethanol by distillation requires a high amount of thermal energy [2]. Distillation consumes half of the total production energy 5.6 MJ/Liter out of 11.1 – 12.5 MJ/Liter. To cope with this high energy demand and improve the benefits from the process, the concept of polygeneration and hydrothermal treatment especially when dealing with small scale ethanol plants is fast gaining interest. However, the analysis of the bioethanol process shows that distillation is still the most widely used. Heat integration of distillation and rectification is known to give the largest reduction of heat demand.

Heat pumping has been known as an economical energy integration technology for reduction in consumption of primary energy and to minimize negative impact of large cooling and heating demands to the environment. Literature is replete with studies on distillation column with direct vapor recompression heat pump and distillation column assisted by an external heat pump [3]-[5]. Most of these concluded that heat pumping is an effective means of saving energy and reducing column size without estimating the actual energy consumption and the parameters that are likely to have significant effect on energy consumption.

Estimating the actual energy consumption is an important aspect towards the determination of the viability of the system in ethanol-water separation. Few works have been done on the combined effect of these parameters [6], [7]. Hence the purpose of this study is to estimate heat loss and its direct and indirect effect on reboiler heat transfer rate, total energy consumption, thermodynamic efficiency and heat pump condenser distribution factor on column with combined effects of pressure increase across the compressor and the overall heat transfer coefficient as an explicit function of dimensionless Prandtl, Reynolds and Nusselt numbers.

## II. MODEL DEVELOPMENT

### A. Calculation of Column Parameters

The system consists of a distillation column with heat exchangers, auxiliary reboiler, reboiler-condenser and

C.C.Enweremadu is with the Mechanical Engineering Department, Vaal University of Technology, 1900 South Africa (phone: +27 16 950 9158; fax: +27 16 950 9797; e-mail: chrise@vut.ac.za).

H.L.Rutto is with the Department of Chemical Engineering, Vaal University of Technology, 1900 South Africa (e-mail: hilaryr@vut.ac.za).

compressor, (Fig. 1). In this vapour recompression distillation system there is a direct coupling between the distillation column and the rest of the system. Also the heat pump working fluid is the column's own fluid which is a binary mixture of ethanol and water at composition  $X_D$ .

where

$$R_{\min} = \frac{1}{(\alpha - 1)} \left[ \frac{X_D}{X_F} - \frac{\alpha(1 - X_D)}{(1 - X_F)} \right] \quad (7)$$

$k$  is described as a function of optimum reflux ratio which corresponds to a fraction of the distillate ( $D$ ) that returns to the column.

$\alpha$  is the relative volatility. Therefore,

$$L_1 = R_r \cdot D \quad (8)$$

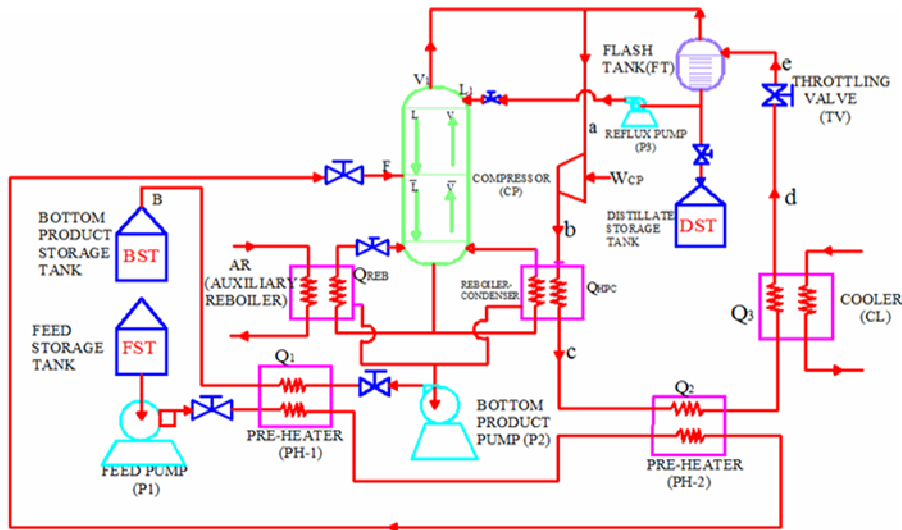

Fig.1 Schematic diagram of vapour recompression distillation column

Considering an overall material and component material balance,

$$F = D + B \quad (1)$$

$$FX_F = DX_D + BX_B \quad (2)$$

where  $F$  is the feed flow rate,  $D$  is the distillate flow rate,  $B$  is the bottom flow rate,  $X_B$  is the mole fraction of the bottom product and  $X_F$  is the mole fraction of the most volatile component in the feed (liquid-phase composition of the feed). From equation (1), the mass flow rate of the bottom product is given as

$$B = F - D \quad (3)$$

From (2) and (3), the mass flow rate equation for the distillation column becomes

$$FX_F = DX_D + BX_B = DX_D + FX_B - DX_B \quad (4)$$

Thus, the mass flow rate of the distillate product is given as

$$D = \frac{F(X_F - X_B)}{(X_D - X_B)} \quad (5)$$

An important part of the design of any distillation column is the choice of the actual reflux ratio,  $R_r$ . This is calculated as a function of minimum reflux ratio,  $R_{\min}$ . Then,

$$R_r = kR_{\min} \quad (6)$$

$L_1$  is the saturated liquid molar flow rate which returns to the top of the column.

From a material balance on the condenser, it can be stated that

$$V_1 = L + D \quad (9)$$

where,  $V_1$  is the vapour molar flow rate which leaves the top of the column and feeds the condenser.

The overall energy balance equation applied to a control volume comprising the column and the feed pre-heaters provides the total energy demand in the reboiler:

$$Q_{reb} = Dh_D + Bh_B + L_1h_{LV,e} + Q_{losses} - Fh_F - Q_1 - Q_2 \quad (10)$$

where  $Q_{reb}$  is the total heat load added to the reboiler;  $Q_{losses}$  represent the heat losses in the column, which are to be determined;  $Q_1$  and  $Q_2$  are the heat loads of the pre-heaters;  $h_{LV,e}$  is latent heat of vaporisation downstream of throttling valve;  $h_D$ , is the enthalpy of the distillate;  $h_B$  is the enthalpy of the bottom product;  $h_F$ , is the enthalpy of the feed.

The mass balance variables are determined as follows:

The vapour molar flow rate, leaving the reboiler is given as

$$V_2 = \frac{Q_{reb}}{h_{LV,cev}} \quad (11)$$

where  $h_{LV,cev}$  is the latent heat of vaporization of the liquid having composition  $X_B$  of the bottom product. Since the column is fed with a mixture primarily containing water, the heat of vaporization of water is used.

The feed vapour flow rate is expressed as

$$V_F = V_1 - V_2 \quad (12)$$

The feed conditions can be defined by  $q$ , which is the feed vapour fraction that enters the column. Thus,

$$q = \frac{V_F}{F} \quad (13)$$

where  $q < 0$ , subcooled liquid;  $q = 0$ , saturated liquid;  $0 < q < 1$ , vapour – liquid mixture;  $q = 1$ , saturated vapour;  $q > 1$ , superheated vapour.

Thus, the liquid molar flow rate of the feed  $F$  becomes:

$$L_F = F - V_F \quad (14)$$

Also, the vapour molar flow rate remaining at the bottom of the column is given as:

$$L_2 = L_1 + L_F \quad (15)$$

At the rectifying section of the column, the liquid molar flow rate and the vapour molar flow rate are expressed, respectively as:

$$L = L_1 \quad (16a)$$

$$V = V_1 \quad (16b)$$

and, at the stripping section

$$\bar{L} = L_2 \quad (17a)$$

$$\bar{V} = V_2 \quad (17b)$$

The design procedure for a tray distillation column consists of determining the liquid and vapour composition from top to bottom, along the column. The compositions at the top ( $X_D$ ) and bottom ( $X_B$ ) of the column are previously pre-established data. In this study, the number of theoretical stages ( $N_{min}$ ) is calculated using Fenske's equation [8]:

$$N_{min} + 1 = \frac{\log\left(\frac{X_D}{1 - X_D} \cdot \frac{1 - X_B}{X_B}\right)}{\log \alpha} \quad (18)$$

where  $\alpha$  is expressed as

$$\alpha = \frac{A_{H_2O}}{A_{EtOH}} \quad (19)$$

$A_{H_2O}$  is the activity coefficient for water and  $A_{EtOH}$  is the activity coefficient for ethanol. The activity coefficients are determined using Vaan Laar equation [9]:

$$A_{H_2O} = \exp\left[A_{21}\left(\frac{A_{12}X_D}{A_{12}X_D + A_{21}X_B}\right)^2\right] \quad (20)$$

$$A_{EtOH} = \exp\left[A_{12}\left(\frac{A_{12}X_B}{A_{12}X_D + A_{21}X_B}\right)^2\right] \quad (21)$$

The actual number of plates is given by

$$N = \frac{N_{min}}{\eta_T} \quad (22)$$

where  $\eta_T$  is the tray efficiency.

### B. Determination of Column Heat Loss

In determining the heat loss from the distillation column, it is assumed that the temperature is uniform in the space between two plates; thermal capacitance of the column wall material is negligible and convective thermal resistance of the vapour side inside the column is negligible.

The heat transfer between the column wall and the surrounding is then determined from the relationship for overall heat transfer coefficient.

$$Q_{Losses} = U_p A_o \Delta T_p \quad (23)$$

where  $U_p$ , the overall heat transfer coefficient is given by Gani, Ruiz and Cameron [10] as

$$U_p = f(h_o, h_i, K_p, A_o, A_i, A_m, t_{ins}) \quad (24)$$

The temperature difference,  $\Delta T_p$  is given as

$$\Delta T_p = T_p - T_{amb} \quad (25)$$

$h_o$ , the heat transfer coefficient between the surroundings and the column external surface, is given as

$$h_o = f(Nu, K_{ins}, d_o, t_{ins}) \quad (26)$$

$h_i$  is the the heat transfer coefficient inside the column;  $K_p$  is the thermal conductivity of the tray material;  $A_o$  is the external areas of heat exchange;  $A_i$  is the internal areas of heat exchange;  $A_m$  is the logarithmic mean area;  $t_{ins}$  is the thickness of insulation.

The heat output is calculated with the general expression for convection around cylindrical objects.

$$Q_{loss} = \frac{T_p - T_{amb}}{\frac{1}{h_i A_i} + \frac{\ln(r_{owall}/r_{wall})}{K_{wall} \cdot A_{wall}} + \frac{\ln(r_{ins}/r_{owall})}{K_{ins} \cdot A_m} + \frac{1}{h_o A_o}} \quad (27)$$

The column inner surface heat transfer resistance is neglected as the heat transfer coefficient for condensing vapor is large and therefore will have little effect on the overall heat transfer.

For the case considered in this study, the column is hot and extra reboiler duty is used. Based on the earlier assumptions the heat transfer due to free convection between the surroundings and the external column wall and due to conduction through the insulation materials is predicted. Also, from geometry of the insulated cylinder (Fig.2), the external diameter of insulation is given as:

$$d_{ins} = d_o + 2t_{ins} \quad (28)$$

The logarithmic mean diameter of the insulating layer is also defined as:

$$d_{ins,m} = \frac{d_{ins} - d_o}{\ln \frac{d_{ins}}{d_o}} = \frac{2t_{ins}}{\ln\left(1 + \frac{2t_{ins}}{d_o}\right)} \quad (29)$$

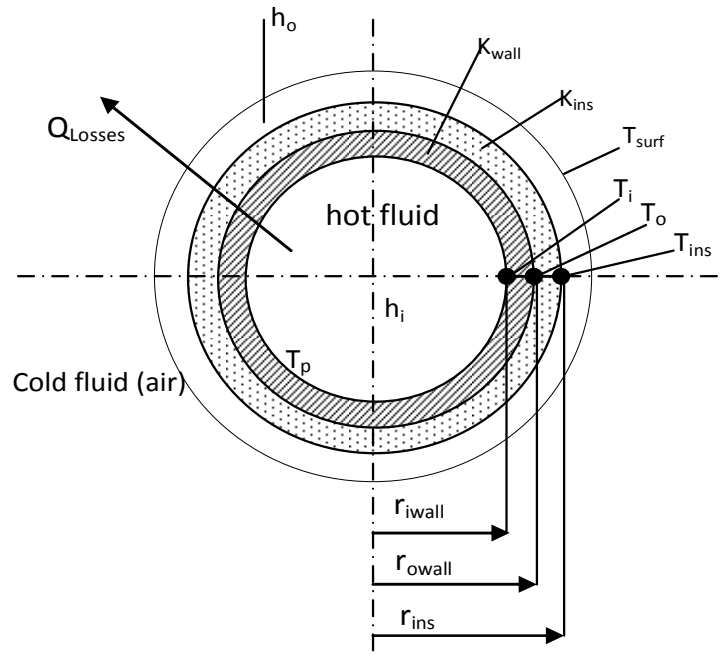

Fig. 2 Section of distillation column with insulation

Hence the external areas of heat exchange is expressed as

$$A_o = \pi d_{ins,m} P_s \quad (30)$$

where  $P_s$  is the tray (plate) spacing

Therefore, the logarithmic mean area ( $A_m$ ) is given as

$$A_m = \frac{2\pi P_s \cdot t_{ins}}{\ln\left(1 + \frac{2t_{ins}}{d_o}\right)} \quad (31)$$

Using dimensional analysis,

$$h_o = \frac{K_{ins} \cdot Nu}{d_o + 2t_{ins}} \quad (32)$$

where,  $t_{ins}$  is the thickness of insulation

$K_{ins}$  is thermal conductivity of the insulation materials;  $Nu$ , Nusselt number;  $d_o$ , external diameter of column;  $T_{amb}$ , temperature of the surrounding;  $T_p$ , plate temperature.

For vertical cylinders, the commonly used correlations for free convection are adapted from Holman [11] as:

For laminar flow,

$$Nu = 0.59(Gr.Pr)^{1/4} \text{ for } (10^4 < Gr.Pr < 10^9) \quad (33)$$

For turbulent flow,

$$Nu = 0.10(Gr.Pr)^{1/3} \text{ for } (10^9 < Gr.Pr < 10^{12}) \quad (34)$$

where  $Gr$  is the Grashof number defined as

$$Gr = \frac{H^3 g \beta \Delta T}{\nu^2} \quad (35)$$

where the coefficient of thermal expansion of the fluid is

$$\beta = \frac{1}{273 + T_f} \quad (36)$$

Mean film temperature is

$$T_f = \frac{T_{wall} + T_{amb}}{2} \quad (37)$$

$$\Delta T = T_{wall} - T_{amb} \quad (38)$$

$T_{wall}$  is the wall surface temperature;  $T_{amb}$  is the ambient temperature;  $H$  is the column height while  $\nu$  is the kinematic viscosity;  $g$  is the acceleration due to gravity. Prandtl number

$$Pr = \frac{\mu C_p}{K_f} \quad (39)$$

$\mu$  is the fluid dynamic viscosity,  $C_p$  is the specific heat of the boiling liquid and  $K_f$  is the fluid thermal conductivity.

Based on the assumptions of neglecting  $h_i$ ,  $A_i$  and the effect of thermal resistance, (24) reduces to:

$$U_p = f(h_o, K_p, A_o, A_m, t_{ins}) \quad (40)$$

and (27) is given as

$$Q_{losses} = \frac{(T_p - T_{amb}) \pi P_s N}{\frac{\ln(r_{ins}/r_{owall})}{K_p \cdot A_m} + \frac{1}{h_o A_o}} \quad (41)$$

where

$$U_p = \frac{1}{\frac{\ln(r_{ins}/r_{owall})}{K_p \cdot A_m} + \frac{1}{h_o A_o}} \quad (42)$$

The heat loss from the column trays is given by

$$Q_{\text{lossfromtrays}} = \frac{(T_p - T_{\text{amb}})2\pi P_s N}{\frac{\ln(r_{\text{ins}}/r_o)}{K_p} + \frac{1}{\frac{2\pi P_s t_{\text{ins}}}{\ln(1 + \frac{2t_{\text{ins}}}{d_o})} + \frac{K_{\text{ins}} \cdot Nu}{d_o + 2t_{\text{ins}}} \cdot (\pi l_{\text{ins}, m} P_s)}} \quad (43)$$

The total heat loss from the column is expressed as:

$$Q_{\text{loss}} = Q_{\text{lossfromtrays}} + \text{Heatlossfromthetwocylinderheads} \quad (44)$$

Based on the assumptions made, heat loss through the cylinder heads is given by

$$Q_{\text{lossatcylinderheads}} = \frac{2(T_p - T_{\text{amb}})\pi a_o^2}{\frac{t_{\text{ins}}}{K_p} + \frac{1}{h_o}} \quad (45)$$

Therefore,

$$Q_{\text{loss}} = \frac{(T_p - T_{\text{amb}})2\pi P_s N}{\frac{\ln(r_{\text{ins}}/r_o)}{K_p} + \frac{1}{\frac{2\pi P_s t_{\text{ins}}}{\ln(1 + \frac{2t_{\text{ins}}}{d_o})} + \frac{K_{\text{ins}} \cdot Nu}{d_o + 2t_{\text{ins}}} \cdot (\pi l_{\text{ins}, m} P_s)}} + \frac{2(T_p - T_{\text{amb}})\pi a_o^2}{\frac{t_{\text{ins}}}{K_p} + \frac{1}{h_o}} \quad (46)$$

### C. Determination of Overall Heat Transfer Coefficient

The overall heat transfer coefficient between the condenser and the reboiler is expressed as a function of the energy yield by the heat pump to the distillation column and temperature drop in the reboiler-condenser:

$$(UA)_{\text{HPC}} = \frac{Q_{\text{HPC}}}{\Delta T_{\text{CHP}}} \quad (47)$$

However, a more careful analysis reveals that U is an explicit function of Prandtl, Reynolds and Nusselt numbers. The overall heat transfer coefficient referenced to inner surface is given by

$$\frac{1}{U_i} = \frac{1}{h_i} + (r_i/r_o) \frac{1}{h_o} + \frac{r_i \ln(r_o/r_i)}{2K_{\text{wall}}} \quad (48)$$

As thermal resistance of the wall is negligible, ( $K_w$  is large and  $\ln(r_o/r_i) \approx 0$ , it is then compared with the inner tube diameter ( $r_i/r_o \approx 1$ )

Then

$$\frac{1}{U_i} = \frac{1}{h_{i_{\text{ex}}}} + \frac{1}{h_{o_{\text{ex}}}} \quad (49)$$

where

$$h_{o_{\text{ex}}} = \frac{0.023K_m}{d_{o_{\text{ex}}}} (\text{Re}_m)^{0.8} (\text{Pr}_m)^{0.4} \left(\frac{\mu_{\text{wall}}}{\mu_m}\right)^{0.14} \quad (50)$$

where  $\mu_m$  is the mean bulk fluid viscosity and  $\mu_{\text{wall}}$  is the viscosity of the liquid at the wall.

Reynolds number is defined as:

$$\text{Re}_m = \frac{\rho u d_{o_{\text{ex}}}}{\mu_m} \quad (51)$$

Prandtl number is defined as:

$$\text{Pr}_m = \frac{C_{pm} \mu_m}{K_m} \quad (52)$$

The expression for condensation inside tubes is adapted from Holman [8].

$$h_{i_{\text{ex}}} = 0.555 \left[ \frac{\rho_L (\rho_L - \rho_V) K_L^3 g h'_{fg}}{\mu_L d_{i_{\text{ex}}} (T_{\text{CHP}} - T_{\text{wall}})} \right]^{0.25} \quad (53)$$

where

$$h'_{fg} = h_{fg} + 0.375 C_{pL} (T_{\text{CHP}} - T_{\text{wall}}) \quad (54)$$

where  $K_L$  is thermal conductivity of the liquid,  $d_{i_{\text{ex}}}$  is the inside diameter of the reboiler-condenser tubes and  $\mu_L$  is the density of the condensate (liquid). Since  $\rho_V \ll \rho_L$ , then  $\rho_V$  is neglected. Therefore, the overall heat transfer coefficient may be determined from

$$\frac{1}{UA_{\text{HPC}}} = \frac{1}{\frac{0.023K_m}{d_{o_{\text{ex}}}} \left(\frac{\rho_m d_{o_{\text{ex}}}}{\mu_m}\right)^{0.8} \left(\frac{C_{pm}}{K_m}\right)^{0.4} \left(\frac{\mu_{\text{wall}}}{\mu_m}\right)^{0.14}} + \frac{1}{0.555 \left[ \frac{\rho_L (\rho_L - \rho_V) K_L^3 g h'_{fg}}{\mu_L d_{i_{\text{ex}}} (T_{\text{CHP}} - T_{\text{wall}})} \right]} \quad (55)$$

Hence the energy yield by the heat pump to the distillation column  $Q_{\text{HPC}}$  is determined as:

$$Q_{\text{HPC}} = (UA)_{\text{HPC}} \cdot \Delta T_{\text{CHP}} \quad (56)$$

The heat pump distribution factor (the factor by which the heat pump contributes to the heat load of the reboiler) is given by:

$$f = \frac{Q_{\text{HPC}}}{Q_{\text{reb}}} \quad (57)$$

### E. Calculation of Heat Pump Parameters

The calculation of heat pump parameters begins with the estimation of the working fluid condensation temperature obtained from the reboiler temperature and temperature drop across the heat exchangers as:

$$T_{\text{CHP}} = T_{\text{CEV}} + \Delta T_{\text{CHP}} \quad (58)$$

where  $T_{\text{CEV}}$  is the column vaporization (reboiler) temperature and  $\Delta T_{\text{CHP}}$  is the temperature drop in the reboiler-condenser.

The relevant working fluid thermodynamic parameters such as pressures, temperatures, enthalpies, specific volumes, vapour pressures and vapour dryness fraction, etc, were determined from thermodynamic correlations and calculated using POLYMATH Numerical Solution for Scientific Problems [12]

where necessary. These are presented in detail in Enweremadu[13].

The energy balance, applied to the heat pump working fluid, yields the available energy for exchange at the condenser, as follows:

$$Q_{cd} = \dot{M}[C_p(T_b - T_{CHP}) + (1 - \beta_c)h_{LV,CHP}] \quad (59)$$

In order to control the heat load, a comparison is made between the energy available at the condenser,  $Q_{cd}$ , with the energy required by the column reboiler,  $Q_{reb}$  in accordance with Oliveira et al [14]:

$$\text{If } Q_{cd} > Q_{reb} \text{ then } Q_{HPC} = Q_{reb} \quad (60)$$

$$\text{if } Q_{cd} \leq Q_{reb} \text{ then } Q_{HPC} = Q_{cd} \quad (61)$$

The following compressor parameters were calculated thus:  
Compressor power input

$$\dot{W}_{cp} = \frac{\dot{M}}{\eta_{pol}} \frac{n}{n-1} P_a v_a \left[ \left( \frac{P_b}{P_a} \right)^{\frac{n}{n-1}} - 1 \right] \quad (62)$$

The pressure ratio  $\frac{P_b}{P_a}$  (pressure increase to be provided by the compressor) is crucial to the power requirement and is influenced by the following:

1. Pressure drop in vapour ducts, and over valves and fittings,  $\Delta P_p$ .
2. Pressure drop across the column,  $\Delta P_{cl}$ .
3. The pressure difference in boiling points between the top and bottom products,  $\Delta P_b$ .
4. Temperature-difference in the reboiler can be expressed by means of the vapour pressure equation as a pressure difference,  $\Delta P_{CHP}$ .

The detailed calculations of each of these pressure components are given by [13].

The necessary pressure drop across the compressor becomes:

$$\Delta P = \Delta P_b + \Delta P_{cl} + \Delta P_{CHP} + \Delta P_p \quad (63)$$

Thus, the pressure ratio is

$$\frac{P_b}{P_a} = \frac{P_{CHP} + \Delta P}{P_{TOP}} \quad (64)$$

Hence, equation (52) becomes

$$\dot{W}_{cp} = \frac{\dot{M}}{\eta_{pol}} \frac{n}{n-1} RT_{TOP} \left[ \left( \frac{P_{CHP} + \Delta P}{P_{TOP}} \right)^{\frac{n}{n-1}} - 1 \right] \quad (65)$$

where n is the polytropic index determined from

$$\frac{n}{n-1} = \eta_{pol} \frac{\gamma}{\gamma-1} \quad (66)$$

#### F. Determination of Energy Effectiveness and Total Energy Consumption

Since vapour recompression uses refrigeration cycle, the heat pump coefficient of performance is defined according to the following relation:

$$\text{COP} = \frac{Q_{HPC} + Q_{23}}{\dot{W}_{cp}} \quad (67)$$

Also, distillation column with vapour recompression uses the column working fluid as refrigerant and does not execute a closed cycle. Hence the excess heat which may occur is not assessed by an overall energy balance but according to Oliveira et al [15]:

$$\text{if } Q_{cd} > Q_{reb} \text{ then } Q_{23} = Q_{cd} - Q_{reb}$$

$$\text{if } Q_{cd} \leq Q_{reb} \text{ then } Q_{23} = 0 \quad (68)$$

The distribution of the excess heat rate,  $Q_{23}$  between the pre-heater ( $Q_2$ ) and cooler ( $Q_3$ ) is accomplished by controlling the feed condition pre-heated by  $Q_2$  i.e. the value of  $Q_2$  should be such that the feed reaches a prescribed condition. The preheating of the feed is carried by  $Q_1$  and  $Q_2$ . Heat  $Q_1$  results from the heat exchanged between the bottom product and the feed, while heat  $Q_2$  results from that exchanged between the heat pump working fluid and the feed. It is verified to ascertain if  $Q_1$  is sufficient to preheat the feed to reach the desired condition. This heat is determined as:

$$Q_1 = B.Cp_B(T_{CEV} - T_{BE}) \quad (69)$$

where  $T_{CEV}$ , is the column evaporation temperature  $C_{PB}$  is the specific heat of the bottom product.  $T_{BE}$  is the temperature at the bottom product flow exit. Otherwise the amount of heat that should be withdrawn from the pre-heater  $Q_2$ , is determined as:

$$Q_w = F.Cp_F(T_{sat,F} - T_F) + 0.5Fh_{LV,F} \quad (70)$$

The value,  $Q_2$  should be, at the most equal to  $Q_w$  to prevent the feed reaching 50% dry. Therefore, a convenient heat load control is made as follows:

$$\text{If } Q_{23} > Q_w, \text{ then } Q_2 = Q_w \quad Q_3 = Q_{23} - Q_2$$

$$\text{if } Q_{23} < Q_w \text{ then } Q_2 = Q_{23}, Q_3 = 0 \quad (71)$$

For a vapour recompression distillation column, the energy required for separation process (total energy consumption) is composed of the reboiler heat load and the compressor power input

$$Q_T = Q_{reb} + \dot{W}_{cp} \quad (72)$$

For the separation of a binary mixture by distillation the minimum thermodynamic energy required to achieve complete separation is given by Liu and Quian [16]:

$$W_{min} = -RT_{TOP}(X_F \ln(X_F) + (1 - X_F) \ln(1 - X_F)) \quad (73)$$

The thermodynamic efficiency is expressed as:

$$\eta_{VRC} = \frac{W_{min}}{Q_T} \quad (74)$$

### G. Solution Method and Error Analysis

In the vapour recompression distillation system considered, the distillation column and the heat pump are not working as independent units. Therefore, the set of equations are not solved separately as in distillation column assisted by an external heat pump.

The equations that model the system were grouped together and the resultant set of non-linear algebraic equations were coded in VISUAL BASIC to evaluate the unknowns. A control programme (column with negligible heat loss) was written to compare the actual system (column with heat loss). The solution was truncated at the desired error tolerance of 1%.

Error analysis was carried out using the following relationship:

$$\epsilon_a = \frac{X_{i+1} - X_i}{X_{i+1}} \times 100\% \quad (75)$$

## III. RESULTS AND DISCUSSIONS

### A. Direct Effects of Column Heat Loss

The effect of column heat loss could be seen from (46). From the equation, it follows that, for a given reboiler heat load, fewer trays are required for a given separation if heat losses are reduced.

The column heat losses for the two vapour recompression distillation columns are compared in Table I. The results obtained for the VRC<sub>AS</sub> system (column with heat loss) showed a difference as high as 74.3% when compared with that of the VRC<sub>CS</sub> system (column with negligible heat loss) calculated according to Oliveira et al., [14]. Also, the values of main reboiler heat transfer rate in both systems shows the VRC<sub>AS</sub> having a higher value compared to the VRC<sub>CS</sub> system.

TABLE I  
COMPARISON OF THE (ACTUAL) COLUMN WITH HEAT LOSS AND (CONTROL) WITH NEGLIGIBLE HEAT LOSS

Parameter	Actual column (VRC <sub>AS</sub> )	Control column (VRC <sub>CS</sub> )
Column heat loss (kW)	2.62	0.68
Reboiler heat transfer rate (kW)	8.74	6.77
Total energy consumption (kW)	9.26	7.26
Heat pump condenser distribution factor	0.35	0.45
Overall heat transfer coefficient (kW/m <sup>2</sup> K)	1.36	0.34
Coefficient of performance	5.91	6.23
Thermodynamic efficiency (%)	15.8	20.2
Reflux ratio	5.033	7.5

### B. Indirect Effects of Column Heat Loss

In the control system, the reflux ratio was as high as 7.5 compared with 5.033 obtained for the actual system. Therefore if heat losses are properly accounted for, there may not be any need for downward review of the number of plates in order to reduce the reflux ratio.

The energy consumption of the VRC<sub>AS</sub> system relative to VRC<sub>CS</sub> system differ greatly by 27.5% despite the small increase in  $\Delta P$  which increased the compressor power input slightly. The VRC<sub>CS</sub> system has a slightly lower compression ratio and consumes less energy than VRC<sub>AS</sub> system. In addition, the energy consumption appears to depend more on the rate of heat transfer in the reboiler. Obviously, the total energy consumption,  $Q_T$ , appears to be indirectly related to column heat loss and pressure increase across the compressor through  $Q_{reb}$  and compressor power input respectively.

The results also show that the thermodynamic efficiency of the VRC<sub>AS</sub> system is lower than that of VRC<sub>CS</sub> system. This could be explained by the fact that the total energy

consumption in the VRC<sub>AS</sub> system is higher than in the VRC<sub>CS</sub> system.

Analysis of the overall heat transfer coefficient,  $U$  of the heat pump reboiler-condenser revealed an increase in the value of  $U$ . This was expected as the value of  $U$  in boiling and condensation processes are high. Also, the value of the heat transfer coefficient of the condensing ethanol dominated the relationship used in determining  $U$ .

The heat pump distribution factor,  $f$  for the VRC<sub>AS</sub> system is slightly less than that for the VRC<sub>CS</sub> system. Low value of heat load taken by the heat pump implies lower thermal conductance ( $UA$ ). Also for better performance of any heat transfer system, the thermal resistance which is the inverse of thermal conductance should be as low as possible. Therefore the value of the heat transfer area for the VRC<sub>AS</sub> system will be smaller compared to the VRC<sub>CS</sub> system.

## IV. CONCLUSION

In this study, the column heat loss of an ethanol-water vapour recompression distillation column was reported. The

effect was significant for realistic values of total energy consumption, reboiler heat transfer rate and energy effectiveness. The results showed that increase in column heat loss brings about an increase in reboiler heat transfer rate and total energy consumption while the thermodynamic efficiency decreases. Where heat loss occurs, more vapour has to be produced in the reboiler, since the reboiler must provide not only the heat removed in the condenser but also the heat loss. The effect of this is a decrease in process and energy efficiency.

Also, as the heat loss from the column increases, the number of trays increases which in turn increases the column size (height). It is concluded that heat loss calculated for the VRC<sub>AS</sub> system (column with heat loss) showed a remarkable difference when compared with that of the VRC<sub>CS</sub> system (column with negligible heat loss or where the heat loss is assumed to be a certain percent of the reboiler heat transfer rate).

#### REFERENCES

- [1] McMillan, J.D. 1997. Bioethanol production: Status and prospects. *Renewable Energy*, Vol.10. No.2/3, pp. 295-302.
- [2] Pfeffer, M, Wukovits W, Beckmann G & Friedl, A. 2007. Analysis and decrease of the energy demand of bioethanol production by process integration. *Applied Thermal Engineering*. Vol. 27. pp. 2657-2664.
- [3] Null, HR. 1976. Heat Pumps in Distillation. *Chemical Engineering Progress*. pp.58 –64.
- [4] Meili, A. 1990. Heat pumps for distillation columns. *Chemical Engineering Progress*. Vol.6. pp. 60 – 65.
- [5] Fonyo, Z, Benko, N. 1998. Comparison of various heat pump-assisted distillation configurations. *Transactions of Institution of Chemical Engineers*. No.76. Part A. pp. 348-60.
- [6] Enweremadu, CC, Waheed, MA & Ojediran, JO. 2008. Parametric study of pressure increase across a compressor in ethanol-water vapour recompression distillation. *Scientific Research and Essay*. Vol. 3. No.9, pp.231-241.
- [7] Enweremadu, CC, Waheed, MA & Ojediran, JO. 2009. Parametric study of an ethanol-water distillation column with direct vapour recompression heat pump. *Energy for Sustainable Development*. Vol. 13. pp. 96-105.
- [8] Hanley, B. 2001. Calculation of the HETP at total reflux: generalization of the Fenske equation. *Proceedings of the 2001 AIChE Annual meeting: distillation equipment and application*. Wichita, Kansas.
- [9] Jevric, J, Fayed, ME. 2002. Shortcut distillation calculations via spreadsheets. *Reactions and separations*. pp. 60–67.
- [10] Gani R, Ruiz CA & Cameron, IT. 1986. A generalised model for distillation column I: model description and applications. *Computers and Chemical Engineering*. Vol.10. No.3. pp.181-98
- [11] Holman, JP. 2005. *Heat transfer*. 9<sup>th</sup> edition. New York: McGraw-Hill.
- [12] Cutlip, MB, Shacham, M & Elly M. 2006. POLYMATH numerical solution for scientific problems. Professional Release 6.10, 2006.
- [13] Enweremadu, CC. 2007. Simulation of an ethanol-water distillation column with direct vapour recompression heat pump. PhD thesis. Ladoke Akintola University of Technology, Ogbomoso, Nigeria.
- [14] Oliveira, SBM, Marques, RP & Parise, JAR. 2001. Modelling of an ethanol – water distillation column with vapor recompression. *International Journal of Energy Research*. Vol. 25. pp. 845 –58.
- [15] Oliveira, SBM, Marques RP & Parise, JAR. 2002. Modelling of an ethanol – water distillation column assisted by an external heat pump. *International Journal of Energy Research*. Vol. 26. pp.1055 –72.
- [16] Liu X, Quian, J. 2001. Modelling, control and optimization of ideal internal thermally coupled distillation columns. *Chemical Engineering and Technology*. Vol. 23. No.3. pp. 235 – 41.