

Matlab/Simulink-Based Transient Stability Analysis Of A Sensorless Synchronous Reluctance Motor

Mostafa.A. Fellani, Daw .E. Abaid

Abstract—This paper deals with stability analysis for synchronous reluctance motors drive. Special attention is paid to the transient performance with variations in motor's parameters such as L_d and R_s . A study of the dynamic control using d-q model is presented first in order to clarify the stability of the motor drive system. Based on the experimental parameters of the synchronous reluctance motor, this paper gives some simulation results using MATLAB/SIMULINK software packages. It is concluded that the motor parameters, especially L_d , affect the estimator stability and hence the whole drive system.

Keywords—Dynamic Simulation, MATLAB, PWM-inverter, Reluctance Machine, Sensorless Control

I. INTRODUCTION

THE Synchronous reluctance motors have simple construction and are suited for very high speed applications, such as aircraft accessories, robotics, computer peripherals and automotive applications. They are ideal candidates as generators for wind energy conversion systems.

The synchronous reluctance motor is a singly salient machine with its principle of operation based on the existence of variable reluctance in the air gap, high reluctance in the quadrature axis and low reluctance in the direct axis. All the attempts to improve the performance of the synchronous reluctance motor had been focused on modifying rotor magnetic circuit so as to achieve a high saliency ratio L_d / L_q . In recent years, other aspects of performance i.e dynamic and control aspects are attracting much attention [1-4].

In recent years, sensorless vector controlled drive Systems for synchronous reluctance motors become more and more attractive for high-performance servo drive systems (5-7). Unlike the induction motor, the synchronous reluctance motor does not have slip frequency, which is difficult to control precisely due to variation of rotor time constant of the induction motor. It is rather easy to achieve a robust drive system for a synchronous reluctance motor due to the synchronous nature of its operation. Further, the synchronous reluctance motor is inexpensive due to the absence of permanent magnets and a simple rotor structure without cage windings.

rotor position signal for startup and normal operation. The position signal can be obtained from a sensor or an estimator. Extensive research efforts have been devoted to studying the closed-loop control performance of the synchronous reluctance motor with speed and position sensors. However, the sensor brings about several disadvantages e.g. cost, reliability, machine size and noise immunity. Over the last few years, many researchers have focused on the so-called sensorless or indirect sensor control of synchronous reluctance motors to improve the reliability and reduce the cost of such drive systems.

Sensorless control techniques broadly fall into two categories. Firstly, speed sensorless control drive system measures two terminal voltage and current sensors. The speed and/or position is estimated from the measured voltages and currents. Secondly, current sensorless control drive system employs two terminal voltage sensors and a speed/position sensor. The reference current amplitude is derived from stabilization feed forward signal and the primary frequency is increased slowly to keep the motor in synchronism.

With the help of MATLAB & SIMULINK, many kinds of motor-inverter control systems can be easily made, by using the simulating model and control blocks. All parameters can also be changed on line so the better controlling parameters are conveniently determined.

MATLAB is used in controller design and optimization, but does not include sensorless synchronous reluctance motor. The model of sensorless synchronous reluctance motor-drive System is a very complete high orders, non-linear, multiple variables and time-varying system, so there is no general implement in form of MATLAB & SIMULINK and report about this is not seen. It is necessary therefore to implement sensorless synchronous reluctance motor-drive system using MATLAB& SIMULINK.

This paper deals with the stability analysis for senseless synchronous reluctance motors drive system using Matlab. Generally, the motor parameters vary with the; Operating conditions such as temperature, saturation etc. As an example, the d-axis inductance L_d varies from 1.2H to 0.4H with the flux current I_d . It is necessary to investigate the system stability under various operating conditions.

The drive system is modeled using MATLAB and SIMULINK. The dynamic equations and simulation results are given. The parameters of an experimental machine are used as base parameters to simulate the system and study the dynamic performance. The simulation is based on the ideal model of the reluctance synchronous motor with saliency ratio of 5. This ratio is a nominal one selected for the simulation purpose, though higher ratio can be achieved with modem designs of RSMs.

D.E. Abaid is with the Control Engineering department Higher Institute of Electronics, Beni-Walid, Libya Phone No. +218927115265 E-Mail: Dawabaid@gmail.com.

M.A. Fellani is with the Control Engineering department, Higher Institute of Electronics, Beni-Walid, Libya Phone No.+218913774297 Email: Fellani2006@yahoo.com

The cageless synchronous reluctance motor needs an absolute

In the simulation, the dynamic and transient performances are studied using synchronously rotating reference frame.

II. SYNCHRONOUS RELUCTANCE MACHINE DYNAMIC EQUATION

The well-known d-q model of AC machines is widely used for simulation purposes. Based on the assumption that the stator windings are sinusoidally distributed the d-q model is a powerful tool for dynamic simulation of most AC machines including the reluctance synchronous machine.

The equation which describes the behavior of the reluctance synchronous motor can be derived from its d-q axis equivalent circuit Fig. 1.

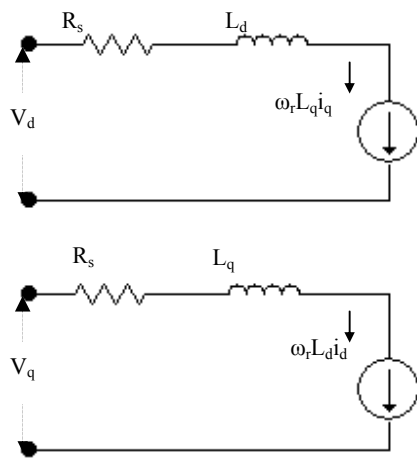

Fig.1 Synchronous reluctance motor d-q axis equivalent circuit

The d-q reference frame equations describing the motor are:

$$V_d = R_s I_d + L_d \frac{dI_d}{dt} - \omega_r L_q I_q \quad (1)$$

$$V_q = R_s I_q + L_q \frac{dI_q}{dt} + \omega_r L_d I_d \quad (2)$$

Where L_d and L_q are the direct and quadrature axis winding self inductance (H), R is the stator winding resistance (Ω) and ω_r is the rotor angular speed in (rad Per second) and it is equal to $\dot{\theta}^*$.

The electromagnetic torque equation is:

$$T_e = \frac{3}{2} p(L_d - L_q)i_d i_q \quad (3)$$

The torque equation in Laplace domain is

$$T = \frac{3}{2} p(L_d - L_q)i_d i_q - (B + JS)\theta^* \quad (4)$$

Where, B and J are the damping fraction and the motor moment of inertia respectively and p is the number of pole pairs and $\dot{\theta}^* = \omega_r$.

III. MATLAB IMPLEMENT OF MOTOR MODEL

In order to simulate any machine the electrical parameters must be known. They can be either measured or calculated. The parameters required for the RSM motor simulation are: the stator resistance R_s , the moment of inertia J, motor damping friction B, the number of pole pairs P and the direct and quadrature-axes self inductances L_d and L_q respectively. The RSM motor model employed in this simulation is a d-q model in synchronously rotating reference frame. Therefore the stationary three phase system of the motor has to be transformed into synchronously two phase system, i.e. d-q model, or vice versa.

The simulation model for the motor was formed from the dynamic equations, which describe the motor (Equations 1-4) and it's as shown in figure 2.

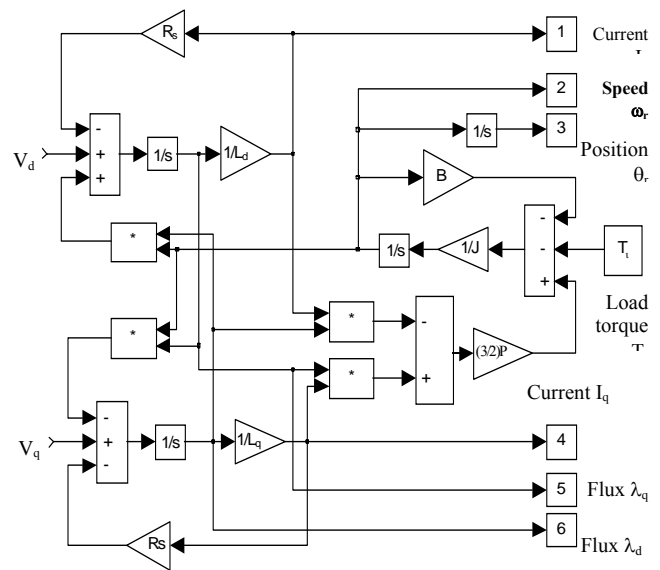

Fig. 2 Simulated motor in the d-q reference frame

IV. SENSORLESS SYNCHRONOUS RELUCTANCE MOTOR DRIVE SIMULATION

To simulate the sensorless synchronous reluctance motor drive using Matlab & Simulink software, the required voltage to produce maximum torque per ampere should be calculated from equations 1-3 as follow:

For maximum torque per ampere $I_d = I_q$, therefore the currents I_d, I_q can be obtained from equation 3 as follows:

$$I_d = \sqrt{\frac{T_e}{\frac{3}{2}P(L_d - L_q)}} \quad (5)$$

$$I_q = \sqrt{\frac{T_e}{\frac{3}{2}P(L_d - L_q)}} \quad (6)$$

Substituting equations (5-6) into equations (1-2) the voltage equations are obtained as follows:

$$V_d = (R_s + SL_d - \omega_r L_q) \sqrt{\frac{T_e}{\frac{3}{2}P(L_d - L_q)}} \quad (7)$$

$$V_q = (R_s + SL_q + \omega_r L_d) \sqrt{\frac{T_e}{\frac{3}{2}P(L_d - L_q)}} \quad (8)$$

Where absolute value of the torque is limited to $(T_e)_{I_{dmax}}$. Figure 3 shows the overall control strategy for controlling the speed and torque of a synchronous reluctance motor based on speed measurement, the values of the voltages V_d, V_q are obtained and the simulation block diagram for the system is as shown in figure 4.

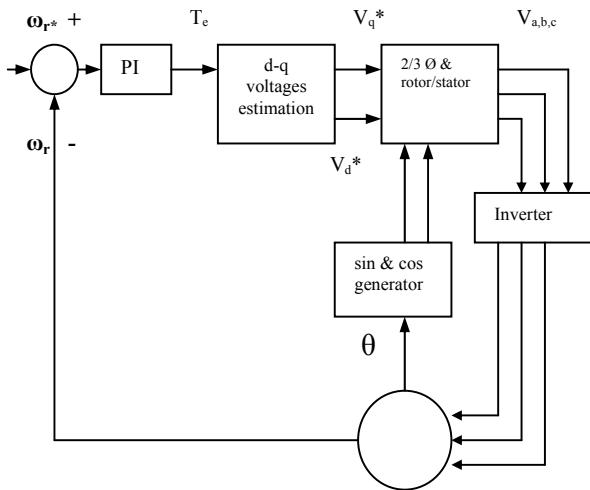

Fig. 3 Sensorless synchronous reluctance motor drive control block diagram.

The voltage command signals which are obtained in the synchronous rotating d-q reference frame are transformed back to the stator reference frame and then used to switch the voltage source PWM inverter.

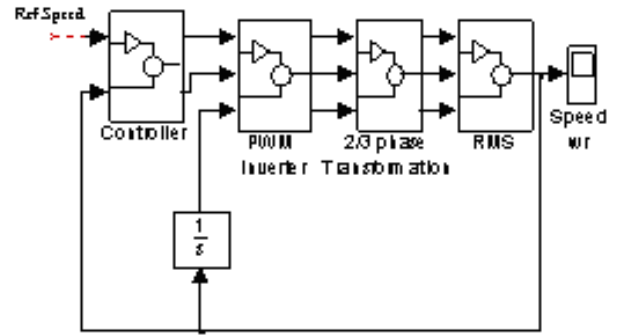

Fig. 4 Simulation block diagram for the SRM drive system

Figure 5. shows the voltage reference controller block diagram details based on equations (7-8) for the sensorless SRM drive system.

In the simulation, the various parameters are obtained from a practical synchronous reluctance machine. The control aspects are studied using synchronously rotating reference frame. The motor parameters L_d and R_s are used both for the motor's model and the estimator. The motor rated parameters are as shown in Appendix. Fixed parameters for estimator are used while the motor parameters are changed according to the operation conditions.

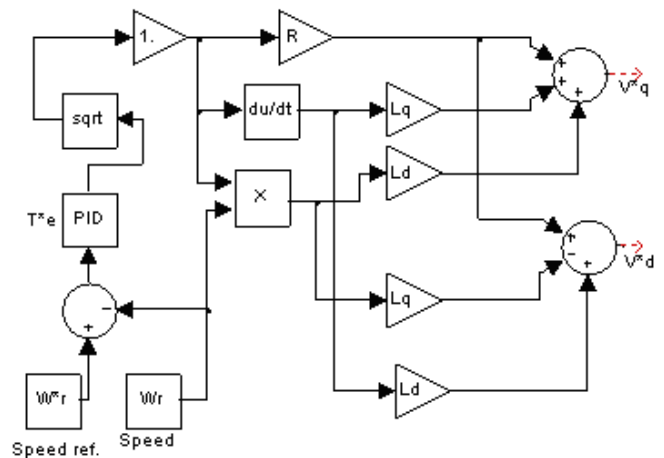

Fig. 5 The voltage reference controller block diagram

Using the simulation diagrams of figure 4-5, the effects of machine parameters detuning specially the d-axis inductance L_d and the stator resistance R_s on the drive transient performance are studied.

V. SENSORLESS DRIVE SIMULATION RESULTS

Sensorless synchronous reluctance motor drive without speed or position sensors has been simulated using Matlab &

Simulink software packages and the dynamic responses have been obtained. The simulation results is based on a 2-pole ALA-rotor RSM model, whose L_d and L_q inductances are measured experimentally. L_q is found to be fairly independent on the current I_q , while L_d strongly dependent on the current I_d as shown in table I.

TABLE I
 SYNCHRONOUS RELUCTANCE MOTOR INDUCTANCES MEASUREMENTS

I_d (A)	L_d (H)	L_q (H)
0.3	1.2	0.08
0.4	1.1	0.08
0.5	1.0	0.08
0.6	0.9	0.08
0.7	0.8	0.08
0.8	0.7	0.08
0.9	0.6	0.08
1.0	0.55	0.08
1.2	0.51	0.08
1.4	0.48	0.08
1.6	0.45	0.08
1.8	0.42	0.08
2.0	0.4	0.08

To test the transient stability of the proposed sensorless synchronous reluctance motor drive, the inductance L_d value varies between $\pm 15\%$ of the nominal value of $L_d=0.4H$ at reference speed of $\omega_r=200$ rad per second. Figure 6 shows different speed responses for different values of motor inductance L_d .

Figure 7 shows the speed responses for different values of stator resistance R_s varied between $\pm 15\%$ of the nominal value of $R_s=18 \Omega$ at reference speed of $\omega_r=200$ rad per second.

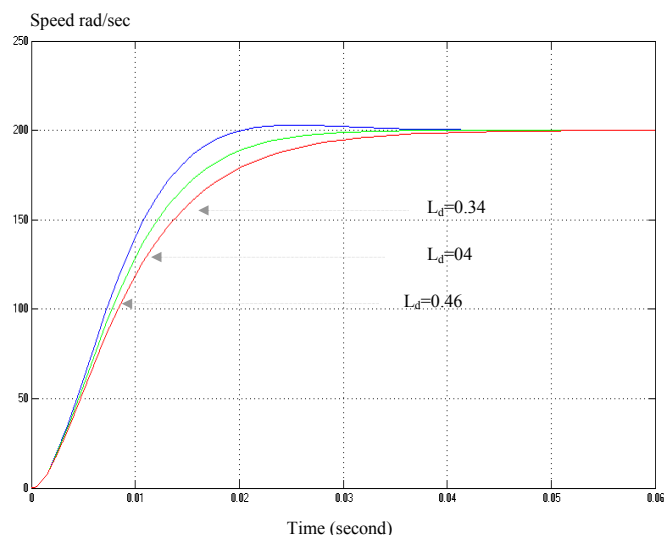

Fig. 6 speed responses for different values of motor inductance L_d .

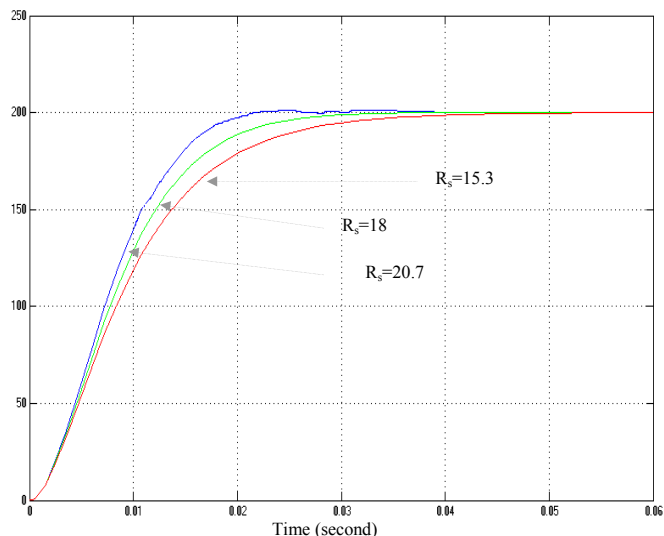

Fig. 7 speed responses for different values of stator resistance R_s

VI. CONCLUSIONS

The performance of sensorless reluctance motor-inverter control system has been analyzed by using MATLAB & SIMULINK. Although the model of the reluctance motor is complicated, the implement produced in this paper is accurate and useful. The experimental parameters are used as base parameters.

With MATLAB & SIMULINK facilities, sensorless reluctance motor-inverter control drive systems can be directly implemented and simulated. The configuration and all parameters of control systems can be easily changed on line.

The simulation results shows that L_d and R_s affect the dynamic performance of the drive system, especially L_d should be giving more attention as it varies a lot. Further investigation should be done to eliminate these sensitivities of the drive system to the motor parameters detuning.

APPENDIX

TABLE II
 PARAMETERS OF THE BASE MACHINE

Parameters	Values	Units
L_d	0.4	H
L_q	0.08	H
R	18	Ω
j	0.001	$K_g m^2$
K	0.007	Nm-sec/rad
P	1	
Switching frequency	5	KHz
V_{dc}	200	Volts
T_r (A)	0	Nm

REFERENCES

- [1] O. Lagerquist, R., Boldea, I., and Miller, T.J.E., "Sensorless control of the synchronous reluctance motor", *IE Transactions on Industry Applications*, vol. 30, no. 3, pp. 673–682, May/June 1994.
- [2] Matsuo, T., and Lipo, T.A., "Rotor position detection scheme for synchronous reluctance motor based on current measurements", *IEEE Transactions on Industry Applications*, vol. 31, pp. 860–868, July/August 1995.
- [3] Schroedl, M., and Weinmeier, P., "Sensorless control of reluctance machines at arbitrary operating conditions including standstill", *IEEE Transactions on Power Electronics*, vol. 9, no. 2, pp. 225–231, March 1994.
- [4] Arefeen, M.S., Ehsani, M., and Lipo, T.A., "Elimination of discrete position sensor for reluctance synchronous motor", *IEEE Power Electronics Specialists Conference – PESC*, pp. 440–445, 1993.
- [5] Jansen, P.L., and Lorenz, R.D., "Transducerless position and velocity estimation in induction and salient A.C machines", *IEEE Transactions on Industry Applications*, Vol. 31, no. 2, pp. 240–247, March/April 1995.
- [6] Xiang, Y.Q., and Nasar, S.A., "Estimation of rotor position and speed of a synchronous reluctance motor for servo-drives", *IEE Proc.-Electr.Power.Appl.* Vol. 142, no. 3, pp. 201–205, May 1995.
- [7] Bowman, R., and Platt, D., "Estimation of rotor position from terminal measurements for a stationary reluctance motor", *Australasian Universities Power Engineering Conference*, pp. 45–49, 1993.
- [8] Bolognani, S., "Torque angle calculator for sensorless reluctance motor drives", *EPE Firenze*, pp. 4013-4017, 1991.
- [9] Boldea, Z. I., and Nasar, S.A., "Torque vector control (TVC) of axially-laminated anisotropic (ala) rotor reluctance synchronous motors", *Electric Machines and Power Systems*, vol. 19, pp. 381–398, 1991.
- [10] Sawata, T., Kjaer, P.C., Cossar C., Miller THE. [1998] "A study on operation under faults with the single-phase SR Generator", *13th Annual Applied Power Electronics Conference*, Anaheim, USA, 15-19 February 1998, Vol.2, pp.1040-1046, 1998.
- [11] Aihara, T; Toba, A.; Yanase, T; Mashimo, A.; Endo, K. "Sensorless torque control of salient-pole synchronous motor at zero-speed operation", *IEEE Transactions on Power Electronics*, Volume: 4, Page(s): 202-208, Jan. 1999.
- [12] Luk, P.C. -K.; Jinupun, P. "Direct torque sensorless control for switched reluctance motor drives", *Electric Machines and Drives*, *International Conference IEMD'99*, Page(s): 28-30, 1999.
- [13] The Math Works Inc., "SIMULINK User's Guide", April 1996.
- [14] Math Works Inc; "MATLAB User's Guide", March 1997.