

Various Information Obtained from Acoustic Emissions Owing to Discharges in XLPE Cable

Tatsuya Sakoda, Yuta Nakamura, Junichiro Kitajima, Masaki Sugiura, Satoshi Kurihara, Kenji Baba, Koichiro Kaneko, Takayoshi Yarimitsu

Abstract—An acoustic emission (AE) technique is useful for detection of partial discharges (PDs) at a joint and a terminal section of a cross-linked polyethylene (XLPE) cable. For AE technique, it is not difficult to detect a PD using AE sensors. However, it is difficult to grasp whether the detected AE signal is owing to a single discharge or not. Additionally, when an AE technique is applied at a terminal section of a XLPE cable in salt pollution district, for example, there is possibility of detection of AE signals owing to creeping discharges on the surface of electric power apparatus. In this study, we evaluated AE signals in order to grasp what kind of information we can get from detected AE signals. The results showed that envelop detection of AE signal and a period which some AE signals were continuously detected were good indexes for estimating state-of-discharge.

Keywords—acoustic emission, creeping discharge, partial discharge, XLPE cable

I. INTRODUCTION

THE stable power supply is strongly demanded for the latest advanced information society. From such a viewpoint, the monitoring or the diagnostic apparatus which can be applied even to a power transmission and distribution system in operation should be established. Such apparatus should also be simple to operate and cost less in their installation.

Incidentally, at joint and terminal sections of cross-linked polyethylene insulated vinyl sheath (XLPE) cables, partial discharges (PDs) may occur in defects of insulating materials.

T. Sakoda is with Department of Electrical System Engineering, University of Miyazaki, 1-1 Gakuenkibanadai-Nishi, Miyazaki 889-2192 Japan (e-mail: sakoda@cc.miyazaki-u.ac.jp).

Y. Nakamura is with Department of Electrical System Engineering, University of Miyazaki, 1-1 Gakuenkibanadai-Nishi, Miyazaki 889-2192, JAPAN (e-mail: tc11022@student.miyazaki-u.ac.jp).

J. Kitajima is with Department of Electrical System Engineering, University of Miyazaki, 1-1 Gakuenkibanadai-Nishi, Miyazaki 889-2192, Japan (e-mail: tc12012@student.miyazaki-u.ac.jp).

M. Sugiura is with Department of Electrical System Engineering, University of Miyazaki, 1-1 Gakuenkibanadai-Nishi, Miyazaki 889-2192, Japan (e-mail: tc12012@student.miyazaki-u.ac.jp).

S. Kurihara is with Miyazaki Customer Service Center, Kyushu Electric Power Co., Inc., 4-2-23, Tachibanadorinishi, Miyazaki 880-8544, Japan (e-mail : Satoshi_Kurihara@kyuden.co.jp)

K. Baba is with Miyazaki Customer Service Center, Kyushu Electric Power Co., Inc., 4-2-23, Tachibanadorinishi, Miyazaki 880-8544, Japan (e-mail : Kenji_Baba@kyuden.co.jp)

K. Kaneko is with Miyazaki Customer Service Center, Kyushu Electric Power Co., Inc., 4-2-23, Tachibanadorinishi, Miyazaki 880-8544, Japan (e-mail : Kouichirou_Kaneko@kyuden.co.jp)

T. Yarimitsu is with Miyazaki Customer Service Center, Kyushu Electric Power Co., Inc., 4-2-23, Tachibanadorinishi, Miyazaki 880-8544, Japan (e-mail : Takayoshi_Yarimitsu@kyuden.co.jp)

Because PDs generally lower the insulation performance of XLPE cables, the diagnostics is very important. We focused on the PD detection at joint and terminal sections, made of ethylene propylene rubber (EPR), of a XLPE cable because defects at joint and terminal sections occupy approximately 30% of electric failures in XLPE cables. To detect PDs, we utilize an acoustic emission (AE) technique [1]-[6].

AE wave consists of sound and ultrasonic waves as elastic waves and can be observed when stress or energy is released in materials. The AE signals are detected by a piezoelectric AE sensor set on the surface of a test material. From the detection of AE signal, we can grasp occurrence of PDs even under systems in operation.

As with an electromagnetic wave detection technique [7], a noise removal is required even for an AE technique. On the other hand, because AE sensors are directly attached to power apparatus, a complicated removal technique is not required. In the case of measurement on a XLPE cable, most noise components owing to vibration of the XLPE cable are excluded, easily. Thus, the AE sensor can easily detect elastic waves owing to a PD in dielectric material when a PD locates near an AE sensor.

Portable diagnostic instruments with an AE sensor have been sold, recently. The deterioration may be diagnosed even by such instruments; however, diagnosis may not be enough because evaluation of PD location is not carried out. For example, diagnostic instruments which do not locate a PD using several sensors may not be judge whether detected AE signal is from the inside of a XLPE cable or not. In salt pollution area, electric power apparatus is easily damaged by briny air. Creeping discharges may occur at the surface of a joint or a terminal section of a XLPE cable in the salt pollution district, i.e., there is possibility of detection of AE signals owing to creeping discharges.

Also, there is much possibility of occurrence of several PDs at the initial stage of deterioration. Until now, it has not been investigated that detected AE signal is owing to a single discharge or not. To settle the problems, it is desired to pick various information up only from AE signals detected by using a low cost diagnostic instrument.

In this study, we first focused on whether the AE technique can distinguish between PDs and creeping discharges. Additionally, we tried to distinguish between single and plural PDs in material by using an AE technique.

II. EXPERIMENTAL METHODS

A. Generation of inside and outside discharges

Instead of creeping discharge occurred outside a XLPE cable, we here generated discharges at the surface of a plate-like EPR and inside a sandwiched EPR plates. Figure 1 shows the experimental setup for measurements of AE signal and PD current, and Fig. 2 shows electrode arrangements for generation of discharges at the surface of a plate-like EPR and inside a sandwiched EPR plates. A plate-like EPR (200 mm × 200 mm) with thickness of 10 mm, density of 1.19 g/cm³, dielectric constant of 3.0 and volume resistivity of $5 \times 10^{15} \Omega \cdot \text{cm}$ was used here. A couple of copper needle-like electrodes 10 mm in width was arranged on the surface of an EPR plate with length of 110 mm. The gap length of the electrode system was 3 mm. When discharges were generated in EPR, a couple of copper needle-like electrodes was sandwiched by a 20 mm-thick-EPR plate and two EPR plates with a total thickness of 40 mm. AC voltage with frequency of 60 Hz was applied until discharges were generated, and its range was 2 - 4 kV.

A piezoelectric AE sensor with a diameter of 10 mm and the wide frequency sensitivity in the range of 20 kHz to 1000 kHz was arranged at the surface of a CV cable. In the case when AE signals owing to outside discharges were measured, an AE sensor was arranged on the surface of an EPR plate. The distance between the AE sensor and the center of the gap axis of an electrode system was 20 mm. The AE signal detected by the AE sensor was amplified by a preamplifier of 30 dB (Maximum gain: 40 dB) with a frequency band of 2 kHz - 1.2 MHz and a main amplifier of 50 dB (Maximum gain: 40dB) with a low pass filter of 500 kHz, i.e., a total amplification was 80 dB. The signal from the amplifier system was sent to a digital oscilloscope with a sampling frequency of 1 MHz or 50 MHz and then recorded with a computer for further analyses including a fast Fourier transform (FFT).

PD current with a pulse width of several tens ns was detected with a CT sensor and was sent to a digital oscilloscope with a sampling frequency of 100 MHz, which triggered a digital oscilloscope used for recording AE signals. The measurements of the AE signal and the PD current against time (t) elapsed from the voltage application were continuously carried out.

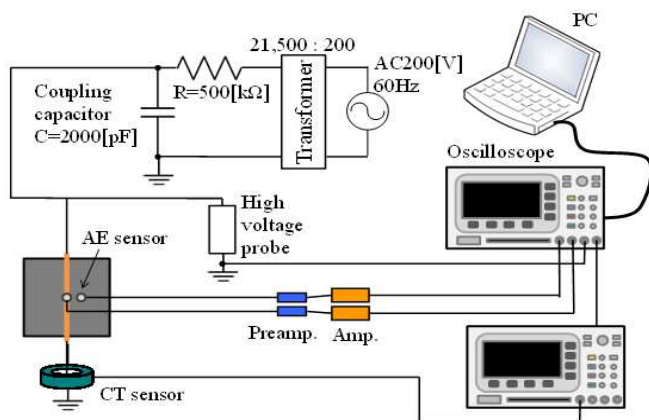

Fig. 1 Experimental setup for AE measurement



(a) Electrode arrangement for outside discharge



(b) Electrode arrangement for inside discharge

Fig. 2 Electrode arrangement for generation of discharges

B. Generation of single discharge and plural discharges

Figure 3 shows our used T-branch joint of XLPE cable for a 22 kV distribution system. Figure 4 shows the experimental setup for measurements of AE signal and PD current, and Fig. 5 shows the arrangement of AE sensors on the surface of a T-branch joint with outer diameter of 86 mm. The insulation taps were connected to the T-branch joint, and two copper needle-like electrodes mentioned in Sec. A were arranged on the surface of the connected insulation tap. The distance between the tip of the copper electrode and the tip of the conductor of T-branch joint was 20 mm. AC voltage with 60 Hz was applied to conductor of the T-branch joint in order to generate discharges and its range was 5 - 10 kV.

AE sensors, preamplifiers, and main amplifiers were the same as those mentioned in Sec. A. Two AE sensors and two earth electrodes were placed every 90 degrees. The sensitivity of "Sensor B" system is about 40% lower than that of "Sensor A" system.



Fig. 3 T-branch joint for a 22 kV distribution system

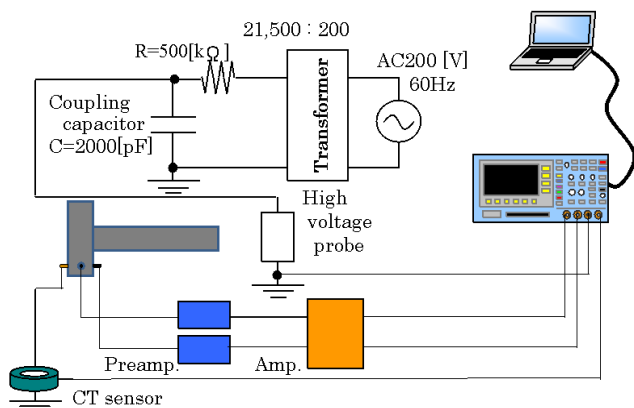

Fig. 4 Experimental setup for generating single or plural discharges on insulation tap connected to a T-branch joint

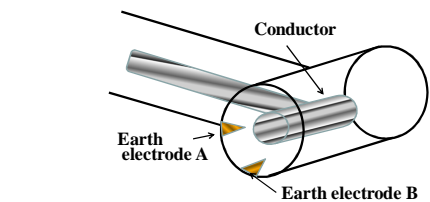
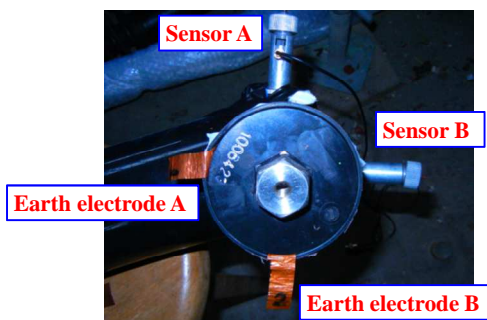
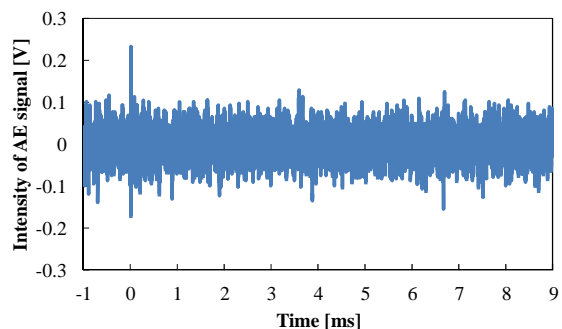

Fig. 5 Arrangement of AE sensors and earth electrodes

III. EXPERIMENTAL RESULTS

A. Distinction between inside and outside discharges

Figure 6 shows AE signals obtained when outside and inside discharges were generated. “0 ms” in this figure means the ignition of discharge. The applied voltages for the outside and the inside discharge were 2.6 kV and 3.7 kV, respectively. However, the leakage currents were the almost same. The maximum current values for the outside and the inside discharge were 2.2 mA and 2.3 mA, respectively. Although the current values were the same, it seemed that waveforms of AE signals were extremely different. The signal decay time in the case of the outside discharge is much shorter than that in the case of the inside discharge. Then, we carried out envelop detection of AE signal. Fig. 7 shows envelopes obtained for the cases of outside and inside discharges. The decay for the case of outside discharge is obviously short.



(a) AE signal in the case of outside discharge

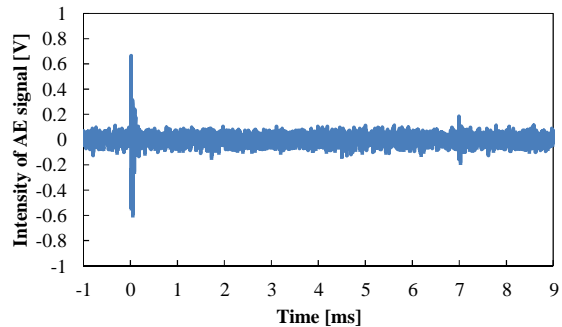

(b) AE signal in the case of inside discharge

Fig. 6 AE signals obtained when outside and inside discharges were generated

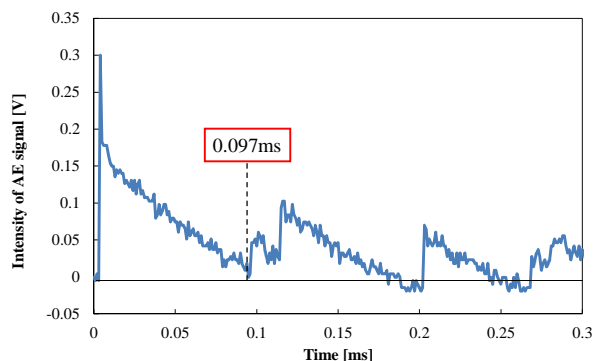

(a) AE signal in the case of outside discharge

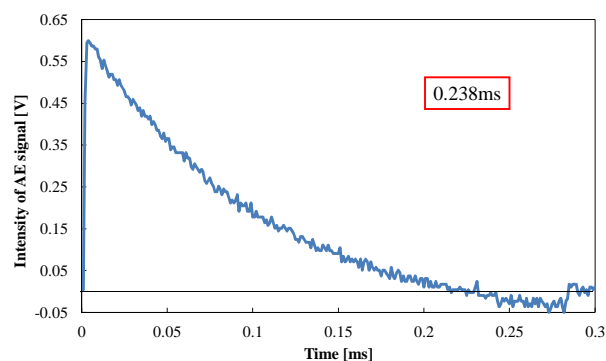

(b) AE signal in the case of inside discharge

Fig. 7 AE signals obtained when outside and inside discharges were generated

Figure 8 shows distribution of decay times for the cases of outside and inside discharges.

The number of measurements was 3 for each discharge. The decay time for the case of outside discharge is in the range of 0.1 to 0.14 ms whereas that for the case of inside discharge is in the range of 0.22 to 0.26 ms. As mentioned before, the leakage currents for both cases were the almost same, i.e., the amounts of energy release owing to discharges might be the almost same. Energy transformed into generation of elastic wave passing EPR may disperses in all directions of EPR in the case of the inside discharge. However, in the case of the outside discharge, energy transformed into generation of elastic wave passing EPR is half. Therefore, the AE signal for the case of the outside discharge is smaller than that for the case of the inside discharge. Additionally, a period which the AE signal is continuously detected is short.

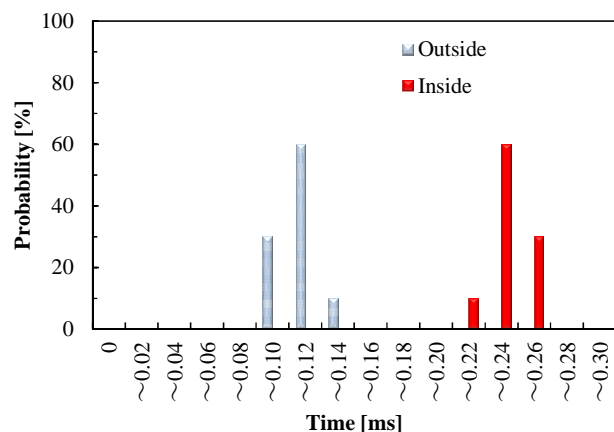
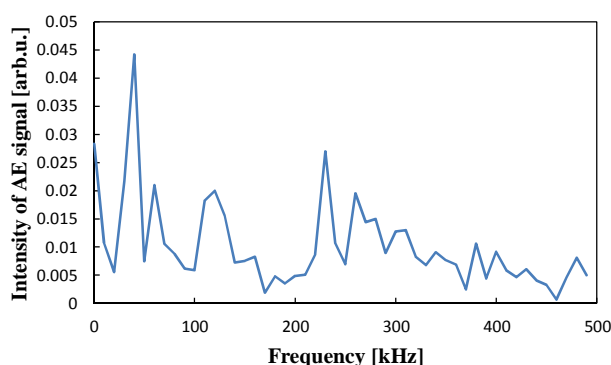

Fig. 8 Distribution of decay time for the cases of outside and inside discharges

Figure 9 shows FFT spectra of AE signals shown in Fig. 6. A frequency component around 60 kHz is extremely larger than other components for the case of the inside discharge (Fig. 9(b)). As shown in Fig. 6, the maximum intensity of AE signal owing to the inside discharge (Fig. 9(a)) is 3 times larger than that owing to the outside discharge. Thus, the large AE signal for the case of the inside discharge is mainly due to a frequency component around 60 kHz. In contrast, the intensity around 60 kHz for the case of the outside discharge is much small (about one-sixth) in comparison with that for the case of the inside discharge. Instead of frequency component of 60 kHz, frequency component around 40 kHz and higher frequency components than 200 kHz are large.

Thus, envelop detection is useful for distinguishing between the inside and the outside discharge, i.e., between PDs or creeping discharge on the surface of a joint / terminal section of a XLPE cable. If adding frequency information obtained from detected AE signal, the distinction accuracy will be higher.



(a) Outside discharge

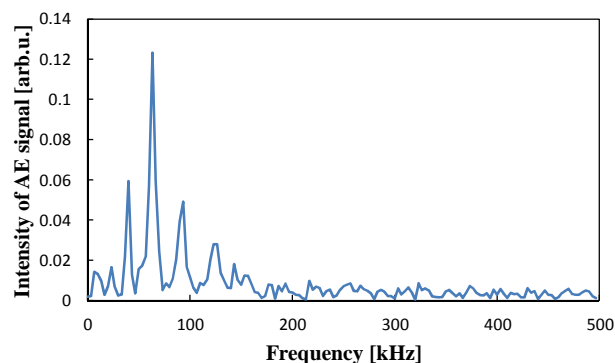

(b) Inside discharge

Fig. 9 FFT spectra obtained from AE signals for the cases of the outside and inside discharges

B. Distinction between single and plural discharges

Typical waveforms of AE signals obtained by “Sensor A” and “Sensor B” when AC voltage was applied only to “Earth electrode A” are shown in Fig. 10. “0 ms” in this figure means the ignition of discharge. There is a time difference of 0.012 ms in detection of AE signals by “Sensor A” and “Sensor B”. We have already investigated velocity of AE wave in EPR. [6] Considering the velocity of 1300 m/s, the calculated distance is 16 mm. The distance between the tip of “Earth electrode A” and “Sensor A” was 45.3 mm, and that between the tip of “Earth electrode A” and “Sensor B” was 61.3 mm. The different distance is 16 mm. Then, we first confirmed that our AE sensor system could detect a discharge generated at the tip of “Earth electrode A”, correctly. Incidentally, the maximum intensity detected by “Sensor A” was 1.06 V whereas that by “Sensor B” was 0.52 V. The reason why the detected intensity by “Sensor B” is small is that the sensitivity of “Sensor B” system is about 40% lower and that elastic waves attenuated during passing through EPR.

Next, we show FFT spectra of Fig. 10 in Fig. 11. A frequency component obtained by “Sensor A” is large at around 60 kHz. In contrast, a frequency component at around 100 kHz is larger than at around 100 kHz. This may be due to attenuation of main component of 60 kHz.

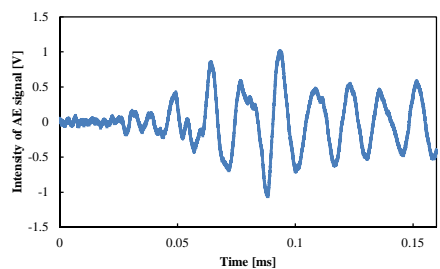

(a) AE signal waveform by "Sensor A"

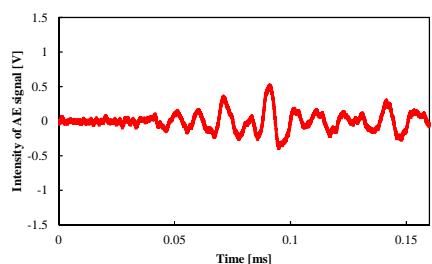

(b) AE signal waveform by "Sensor B"

Fig. 10 Typical waveforms of AE signals due to a single discharge

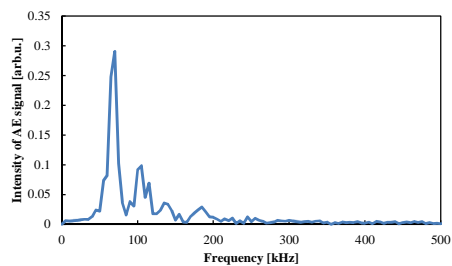

(a) AE signal waveform by "Sensor A"

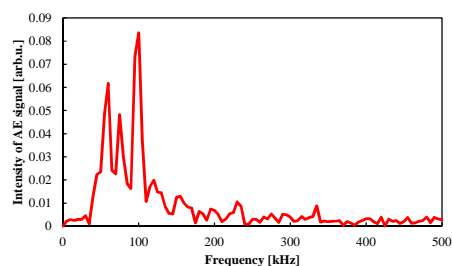

(b) AE signal waveform by "Sensor B"

Fig. 11 FFT spectra of AE signals shown in Fig. 10

AE signals obtained by arranging one or two earth electrodes are shown in Figs. 12 and 13, respectively. The maximum leakage current in the case of arranging "Earth electrode A" was 6.76 mA, and the maximum intensity of detected AE signal was 0.55 V.

Also, when arranging two earth electrodes of "Earth electrode A" and "Earth electrode B", detected leakage currents at "Earth electrode A" and "Earth electrode B" were 1.62 mA and 3.55 mA, respectively.

The intensity of AE signal detected by "Sensor A" was 0.53 mV whereas that by "Sensor B" was 0.51 mV. Because the leakage current detected at each earth electrode, we tried to convert using the leakage current and the intensity of AE signal detected under arranging one earth electrode.

The leakage current at "Earth electrode A" was 1.62 mA when two earth electrodes were arranged; therefore, the current was 0.24 times smaller than that by arranging one earth electrode (6.76mA). Until now, we have already investigated that there is linearity between the leakage current and the AE signal intensity.[8],[9] Based on the results obtained by arranging one earth electrode, the AE signal intensity for the case of arranging two earth electrodes might be 0.13 mV which corresponded to that obtained by 0.24×0.55 mV. However, the detected intensity was 0.33 mV, and it was 4 times larger than that expected intensity. In similar, the AE intensity obtained by "Sensor B" when two earth electrodes were arranged was about 1.8 times larger than that expected intensity.

Considering characteristic of "Sensor B" system whose sensitivity is about 40% smaller than "Sensor A" system, it is concluded that the AE intensity obtained by arranging two earth electrodes is about 4 times larger than by one earth electrode. Thus, in the case when the difference of ignition timing between plural discharges is small, the AE intensity becomes large by a fact that two AE waves overlap. Additionally, from analyses of fast Fourier transform of Figs.12 and 13, it was found that spectral distributions of FFT were the almost same as that shown in Fig. 11.

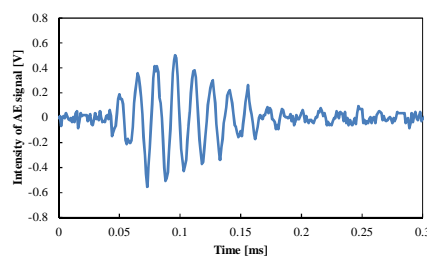
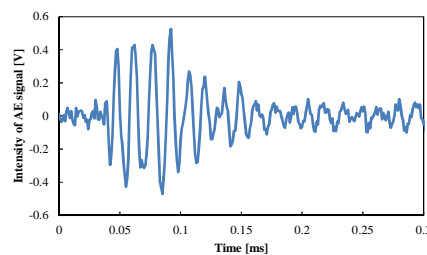
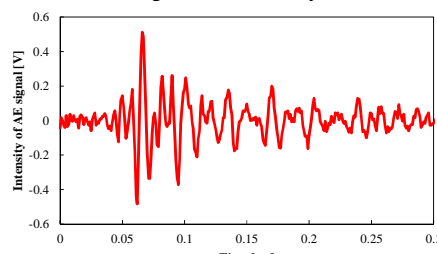

Fig. 12 AE signal by "Sensor A" for a single discharge



(a) AE signal waveform by "Sensor A"



(b) AE signal waveform by "Sensor B"

Fig. 13 AE signals by Sensors A and B for two discharges

By the way, the difference in ignition timing between plural discharges is usually large. The typical AE signal detected by "Sensor A" is shown in Fig. 14.

As can be seen from this figure, two AE waves are continuously detected. Therefore, a period which AE signal was continuously detected becomes long. The period is about 0.5 ms when two discharges were generated and overlapped whereas that when one earth electrode was arranged was about 0.25 ms. However, FFT spectra of Fig. 14 is the almost same as that of Fig. 11(a). Thus, the results indicated that we can distinguish between single and plural discharges by paying attention to a period which AE signal is continuously detected.

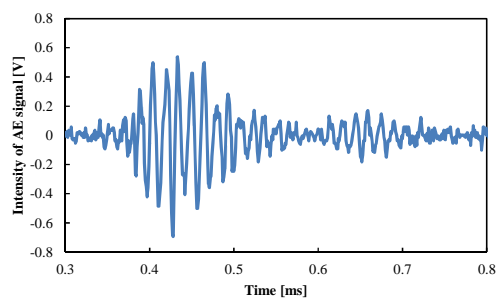

Fig. 14 AE signals when two discharges occurred

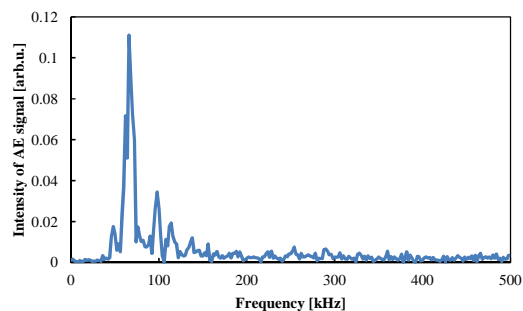

Fig. 15 FFT spectra of AE signal shown in Fig. 14

In this study, we attempted to pick various information up from AE signals detected by piezoelectric AE sensors. The results showed that an envelop detection technique is useful for distinguishing between the inside and the outside discharge, i.e., between PDs or creeping discharge on the surface of a joint / terminal section of a XLPE cable. Additionally, if we refer FFT spectra obtained from detected AE signal, the distinction accuracy might be higher. Additionally, a period which some AE signals were continuously detected was a good index for estimating whether plural discharges occurred or not.

REFERENCES

- [1] T. Sakoda, T. Arita, H. Nieda, K. Ando, M. Otsubo, and C. Honda, "Studies of Elastic Waves Caused by Corona Discharge in Oil", IEEE Transactions on Dielectrics and Electrical Insulation, Vol. 6, No.6, pp. 825-830, Dec. 1999.
- [2] Y. Tian, P. L. Lewin, A. E. Davies, and Z. Richardson, "Acoustic Emission Detection of Partial Discharges in Polymeric Insulation", High Voltage Engineering Symposium, Conference Publication, No. 467, pp. 1.82.S23-1.85.S23, 1999.
- [3] B. T. Phung, R. E. James, T. R. Blackburn, and Q. Su, "Partial discharge ultrasonic wave propagation in steel transformer tanks", 7th International Symposium on High Voltage Engineering, pp. 131-134, 1991.
- [4] T. Sakoda, H. Nieda, and K. Ando, "Characteristics of Elastic Waves Caused by Corona Discharges in an Oil-immersed Pole Transformer", IEEE Transactions on Dielectrics and Electrical Insulation, Vol. 8, No.2, pp. 276-283, Apr. 2001.

- [5] R. T. Harrold, "Acoustical Technology Applications In Electrical Insulation And Dielectrics", IEEE Transactions on Electrical Insulation, Vol.20, pp.3-19, 1985.
- [6] Masanori Takaoka, Tatsuya Sakoda, Masahisa Otsubo, Shigeru Akaiwa, Masatoshi Iki, and Shigeharu Nakano, "Studies of Elastic Waves in Ethylene Propylene Rubber Using Acoustic Emission Sensor", IEEJ Trans. FM, Vol. 128, No. 10, pp.641-645, Oct. 2008.
- [7] H. Borsi, "Digital Location of Partial Discharges in HV Cables", IEEE Trans. on Electrical Insulation, Vol. 27, No. 1, pp. 28-36, 1992.
- [8] Tatsuya Sakoda, Toshihiko Nakashima, Masahisa Otsubo, Satoshi Kurihara, Shinya Nagasato, and Takayoshi Yarimitsu: "Diagnostics of Insulation Deterioration of Ethylene Propylene Rubber Using an Acoustic Emission Technique", IEEE Transactions on Dielectrics and Electrical Insulation, Vol. 17, No. 4, pp.1242-1248, 2010.
- [9] Takuya Yamamoto, Toshihiko Nakashima, Tatsuya Sakoda, Masahisa Otsubo, Satoshi Kurihara, Shinya Nagasato, Takayoshi Yarimitsu: "Studies on Acoustic Emission Signals Detected in an Oil-immersed Pole Transformer, Institute of Electrical Engineers of Japan Transactions on Electrical and Electronic Engineering, Vol. 130, No. 11, pp. 1031-1036, 2010.