

An Impulse-Momentum Approach to Swing-Up Control of Double Inverted Pendulum on a Cart

Thamer Ali Albahkali

Abstract—The challenge in the swing-up problem of double inverted pendulum on a cart (DIPC) is to design a controller that bring all DIPC's states, especially the joint angles of the two links, into the region of attraction of the desired equilibrium. This paper proposes a new method to swing-up DIPC based on a series of rest-to-rest maneuvers of the first link about its vertically upright configuration while holding the cart fixed at the origin. The rest-to-rest maneuvers are designed such that each one results in a net gain in energy of the second link. This results in swing-up of DIPC's configuration to the region of attraction of the desired equilibrium. A three-step algorithm is provided for swing-up control followed by the stabilization step. Simulation results with a comparison to an experimental work done in the literature are presented to demonstrate the efficacy of the approach.

Keywords—Double Inverted pendulum, Impulse, momentum, underactuated

NOMENCLATURE

For the following nomenclature, $i \in \{1, 2\}$.

l_i	Length of the i th link, (m).
d_i	Distance between the i th joint and center of mass of the i th link, (m).
m_i	Mass of the i th link, (kg).
m_0	Mass of the cart, (kg).
I_i	Mass moment of inertia of the i th link about its center of mass, (kgm^2).
x	Distant traveled by the cart, (m).
\dot{x}	Velocity of the cart, (m/s).
θ_i	Angular displacement of the i th, (rad).
$\dot{\theta}_i$	Angular velocity of the i th link, (rad/s).
$\dot{\theta}_i^-$	Angular velocity of the i th link, immediately before the first link is stopped, (rad/s).
$\dot{\theta}_2^+$	Angular velocity of the second link, immediately after the first link is stopped, (rad/s).
v_2	velocity of the center of mass of the second link, (m/s).
v_2^-	Velocity of the center of mass of the second link, immediately before the first link is stopped, (m/s).
v_2^+	Velocity of the center of mass of the second link, immediately after the first link is stopped, (m/s).
xy	Cartesian reference frame fixed to the second link.
XY	Inertial reference frame with unit vectors \vec{i} and \vec{j}

	along the X and Y axes, respectively.
F_x	Force acting on the second link at the second joint along the x -direction, (N).
F_y	Force acting on the second link at the second joint along the y -direction, (N).
F_{imp}	Impulsive force acting on the second link at the second joint, (N).
F	Force acting on the second link at the second joint along the direction of motion of the second joint; it does positive work on the second link (N).
u_{1b}	External force required for braking, i.e., causing exponential decay in the velocity of the cart. Also, maintain $\dot{x} = 0$, (N).
u_{2b}	External torque required for braking, i.e., causing exponential decay in the velocity of the first link. Also, maintain $\dot{\theta}_1 = 0$, (N.m).
u_{2c}	Control torque applied during rest-to-rest maneuver prior to braking, (N.m).
M_{imp}	Impulsive moment acting on the second link at its center of mass, (N.m).
E_2	Total energy of the second link, (J).
E_{2T}	Potential energy of the second link when $(\theta_1, \theta_2) = (\pi/2, 0)$, (J).
g	Acceleration due to gravity, (9.81 m/s^2).
S_i	$\sin \theta_i$.
C_i	$\cos \theta_i$.
S_{12}	$\sin (\theta_1 + \theta_2)$.
C_{12}	$\cos (\theta_1 + \theta_2)$.
R_A	Region of attraction of the desired equilibrium $(x, \dot{x}, \theta_1, \dot{\theta}_1, \theta_2, \dot{\theta}_2) = (0, 0, \pi/2, 0, 0, 0)$.

I. INTRODUCTION

UNDERACTUATED mechanical systems are systems that have fewer control inputs than degrees of freedom. These systems have generated significant interest in the control community since underactuation reduces cost and weight can help deal with actuator failure, and since many systems are naturally underactuated. Underactuated systems pose challenging problems in control because many of the methods developed for completely actuated systems (such as feedback linearization, Lyapunov theory, passivity, etc.) are not directly applicable to underactuated systems.

The double inverted pendulum on a cart (DIPC) is one of the benchmark problems in the nonlinear control field which is considered an underactuated system. Its control problem is similar to many classic underactuated problems such as the inverted pendulum [11], the single pendulum on a cart [35],

T. A. Albahkali is with the Department of Mechanical Engineering, King Saud University, P. O. Box 800, Riyadh 11421, Saudi Arabia (phone: +966-(50)-043-4477; fax: +966(1)-467-6652; e-mail: talbahkali@ksu.edu.sa).

the pendubot [15], and the acrobot [34]. However, the work done on DIPC in the literature is relatively less than that on the mentioned problems. This is mainly due to the limited rail length of the cart.

Nevertheless, Bradshaw and Shao [7] proposed an open-loop unstable, nonminimum-phase, and interactive multi-input multi-output pendulum system which is actively linearized and decoupled about a neutrally stable equilibrium by the partial-state feedback control. In addition, a passivity-based approach is presented by Huang and Fu [9] and Zhong and Rock [5]. They combined their approach with partial feedback linearization. Rubi *et al.* [3] used a technique to design controlled trajectories which is obtained as a result of the optimization of an initial trajectory defined through interpolation by splines. This reference is tracked using a gain scheduling linear quadratic optimal controller specifically designed for the reference trajectory because the obtained trajectory is only an approximate solution for the swing-up problem since the torques acting at the free joints are not identically zero. Simulation and experimental results are provided. Takahashi *et al.* [6] proposed an integrator neural network acquires suitable switching and integration of several controllers for a different local purpose by calculating the fitness function based on the system objective using the genetic algorithm. An integrated controller with three sub-linear quadratic regulator (LQR) controllers is built to stabilize the double pendulum and they provided simulation and experimental results. Niemann and Poulsen [8] studied the problem with H_∞ and the μ methodology. They showed in their study how the limitations of the control signal and the cart movement affect the design of H_∞ and μ controllers. Graichen *et al.* [10] adopted an inversion-based feedforward control design which treats the transition task as a nonlinear two-point boundary value problem of the internal dynamics by providing free parameters in the desired output trajectory for the cart position. They provided experimental results. Xin [12] proposed an energy based swing-up control using a Lyapunov function and stability criteria. Tao *et al.* [4] presented a complicated adaptive fuzzy switched swing-up and sliding controller. It consists of a fuzzy switching controller, an adaptive fuzzy swing-up controller, and an adaptive hybrid fuzzy sliding controller.

Although DIPC swing-up problem can be achieved by one actuator on the cart, it is hard to restrict the cart travel on the rail way to be a very short one because the cart takes the entire burden to pump energy to the system and to balance it at the equilibrium configuration with the highest potential energy. Hence, in this paper we will introduce another actuator at the first joint to share this burden and we will show that the cart travel is going to be very short comparable to that in the literature. Moreover, the first link do not need to make an enormous work and we will illustrate that it is going to pump the energy needed for the swing-up process with only small amplitude of oscillation.

All swing-up methods essentially aim to increase the energy

of the DIPC. Our method is no exception, but we focus on the force of interaction between the two links and the work done by this force on the second link. For swing-up of the DIPC, we instinctively take the cart to origin and hold it there while we take the first link to the vertically upright position and conduct a series of rest-to-rest maneuvers about this configuration that results in swing-up of the second link. Our approach is based on the energy of the system, but it does not impose restrictions on the initial conditions or suffer from any singularity. Furthermore, the rest-to-rest maneuvers allow swing-up in the presence of joint limit restrictions on the first link and the cart travel can also be restricted. A salient feature of our approach is the use of impulsive inputs for the rest-to-rest maneuvers. The idea of using impulsive forces as control inputs is not new, and some of the early work can be credited to Pavlidis [20], Gilbert and Harasty [10], and Menaldi [15]. In recent years, researchers have investigated the problems of stability, controllability, observability, optimality, etc. (see [5], [23], [28], and the references therein), but interestingly, there has been some work on impulse control of underactuated systems. For example, Weibel *et al.* [27] investigated impulse control of a pendulum on a cart, and Aoustin *et al.* [2] investigated control of a biped robot. Wang *et al.* [26] addressed swing-up control of the Furuta pendulum, but a step pulse in the control action, which is a deviation from the standard terminology, is referred to as impulse control. The use of impulsive force provides the scope for a large change in velocity over a short time interval, and this property is exploited in this paper for swing-up of the second link with joint limit restrictions imposed on the first link and the cart travel. Our impulse-momentum approach can be profitably applied to control problems of other underactuated systems, such as the the pendubot [1], acrobot and biped robots [2], but we do not discuss these problems here to focus on the DIPC problem.

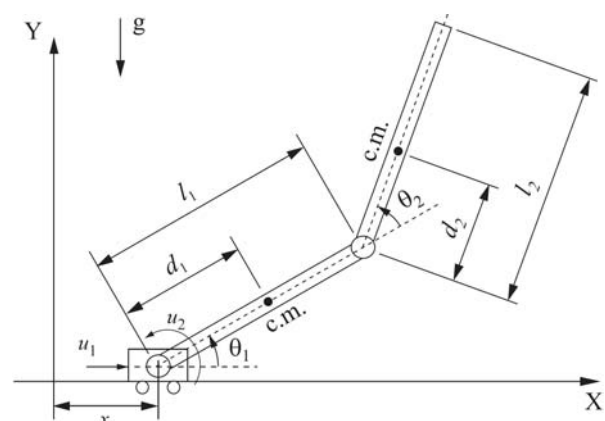

Fig. 1 DIPC in an arbitrary configuration

This paper is organized as follows. In Section II, we present the dynamics of DIPC and derive expressions for the force of interaction between the two links. In Section III, we show the core idea of the paper by explaining the concept of the rest-to-rest maneuver of the first link about its vertically upright

position and the calculations that shows net gain in energy of the second link. It is assumed that the first link is quickly brought to rest at the end of each maneuver by the application of an impulsive braking torque while the cart is hold fixed at the origin by a force. The calculations of the control inputs are shown in section IV. Section V provides the algorithm for swing-up control and stabilization of the desired equilibrium. Section VI presents simulation results based on DIPC parameters in the literature. In addition, we compare the control effort required by our algorithm with that in literature. Finally, we end with concluding remarks at section VII.

II. SYSTEM DYNAMICS

A. Equation of Motion

Consider DIPC in Fig. 1. Assuming no friction on the system, the equation of motion can be obtained using the Lagrangian formulation as follows [14]:

$$A(q)\ddot{q} + B(q, \dot{q}) + G(q) = U \quad (1)$$

where

$$q = \begin{bmatrix} x \\ \theta_1 \\ \theta_2 \end{bmatrix}, \quad U = \begin{bmatrix} u_1 \\ u_2 \\ 0 \end{bmatrix} \quad (2)$$

$$A(q) = \begin{bmatrix} a_{11} & a_{12} & a_{13} \\ a_{12} & a_{22} & a_{23} \\ a_{13} & a_{23} & a_{33} \end{bmatrix} \quad (3)$$

$$B(q, \dot{q}) = \begin{bmatrix} b_1 \\ b_2 \\ b_3 \end{bmatrix}, \quad G(q) = \begin{bmatrix} 0 \\ g_2 \\ g_3 \end{bmatrix} \quad (4)$$

$$\begin{aligned} a_{11} &= m_0 + m_1 + m_2 \\ a_{12} &= -(m_1 d_1 S_1 + m_2 l_1 S_1 + m_2 d_2 S_{12}) \\ a_{13} &= -m_2 d_2 S_{12} \\ a_{22} &= I_1 + m_1 d_1^2 + I_2 + m_2 d_2^2 + m_2 l_1^2 + 2m_2 l_1 d_2 C_2 \\ a_{23} &= I_2 + m_2 d_2^2 + m_2 l_1 d_2 C_2 \\ a_{33} &= I_2 + m_2 d_2^2 \\ b_1 &= -(m_1 d_1 C_1 + m_2 l_1 C_1 + m_2 d_2 C_{12}) \dot{\theta}_1^2 - m_2 d_2 C_{12} \dot{\theta}_2^2 \\ b_2 &= -m_2 (2\dot{\theta}_1 + \dot{\theta}_2) \dot{\theta}_2 l_1 d_2 S_2 \\ b_3 &= m_2 \dot{\theta}_1^2 l_1 d_2 S_2 \\ g_2 &= m_1 g d_1 C_1 + m_2 g (l_1 C_1 + d_2 C_{12}) \\ g_3 &= m_2 g d_2 C_{12} \end{aligned}$$

B. The Force Acting on the Second Link

In order to find the force of interaction between the two links, Newton-Euler method [14] is applied and the force is computed as follows:

$$F_x = m_2 \left[\ddot{x} C_{12} - d_2 (\dot{\theta}_1 + \dot{\theta}_2)^2 + l_1 (\ddot{\theta}_1 S_2 - \dot{\theta}_1^2 C_2) + g S_{12} \right] \quad (5)$$

$$F_y = m_2 \left[-\ddot{x} S_{12} + d_2 (\ddot{\theta}_1 + \ddot{\theta}_2) + l_1 (\ddot{\theta}_1 C_2 - \dot{\theta}_1^2 S_2) + g C_{12} \right] \quad (6)$$

where the directions of F_x and F_y are shown in Fig. 2. The

resultants of F_x and F_y is F_R , which can be decomposed into a workless constraint force along the length of the first link and the component F that does work on the second link. The force F can be expressed in terms of F_x and F_y as follows:

$$F = F_x S_2 + F_y C_2 = m_2 \left[-\ddot{x} S_1 + l_1 \ddot{\theta}_1 + g C_1 + d_2 (\ddot{\theta}_1 + \ddot{\theta}_2) C_2 - d_2 (\dot{\theta}_1 + \dot{\theta}_2)^2 S_2 \right] \quad (7)$$

and since in our swing-up algorithm we will depend on holding up the cart from moving at all during the non-linear controller process, equation (7) reduces to:

$$F = m_2 \left[l_1 \ddot{\theta}_1 + d_2 (\ddot{\theta}_1 + \ddot{\theta}_2) C_2 - d_2 (\dot{\theta}_1 + \dot{\theta}_2)^2 S_2 + g C_1 \right] \quad (8)$$

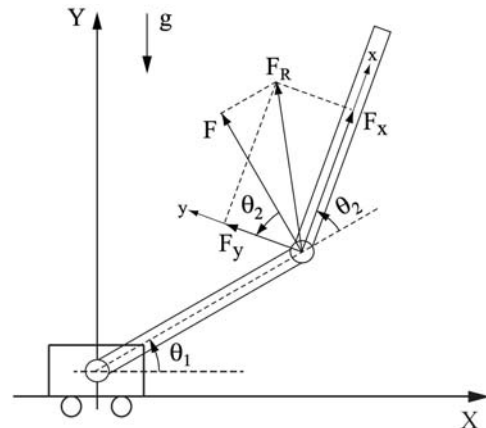

Fig. 2 Force of interaction between the two links of the DIPC

The total energy of the second link can be expressed as follows:

$$E_2 = \frac{1}{2} I_2 (\dot{\theta}_1 + \dot{\theta}_2)^2 + \frac{1}{2} m_2 v_2^2 + m_2 g (l_1 S_1 + d_2 S_{12}) \quad (9)$$

where v_2 is given by the expression

$$\begin{aligned} \vec{v}_2 &= \left[\dot{x} - l_1 \dot{\theta}_1 S_1 - (\dot{\theta}_1 + \dot{\theta}_2) d_2 S_{12} \right] \vec{i} \\ &\quad + \left[l_1 \dot{\theta}_1 C_1 + (\dot{\theta}_1 + \dot{\theta}_2) d_2 C_{12} \right] \vec{j} \end{aligned} \quad (10)$$

By differentiating the expression for E_2 , and taking into consideration that \dot{x} and \ddot{x} is always going to be zero during the swing-up process, we get

$$\begin{aligned} \dot{E}_2 &= m_2 l_1 \dot{\theta}_1 \left[l_1 \ddot{\theta}_1 + d_2 (\ddot{\theta}_1 + \ddot{\theta}_2) C_2 \right. \\ &\quad \left. - d_2 (\dot{\theta}_1 + \dot{\theta}_2)^2 S_2 + g C_1 \right] \end{aligned} \quad (11)$$

Comparing (8) and (11) we can deduce that $\dot{E}_2 = F l_1 \dot{\theta}_1$. This is a confirming results that the rate change in the total energy of the second link is equal to the velocity of the point of application of the force F and has the same direction as that of F .

III. ENERGY CONSIDERATION OF THE SECOND LINK

A. Effect of Suddenly Stopping the First Link

During the swing-up process, while the cart is constantly hold fixed, the first link is going to do a series of rest-to-rest

maneuvers to pump energy to the second link. This means that the first link is going to brake after moving at some time. In our algorithm we will ensure that this braking is going to be extremely fast. Therefore, the action of suddenly stopping the first link has the effect of application of an impulsive force and an impulsive moment on the second link, as shown in Fig. 3. The impulsive force results in a change in the linear momentum of the second link and the impulsive moment results in a change in its angular momentum. The change in the linear and angular momentum of the second link can be expressed as follows:

$$\vec{F}_{imp} \Delta t = m_2 (\vec{v}_2^+ - \vec{v}_2^-) \quad (12)$$

$$\vec{M}_{imp} \Delta t = \vec{r}_2 \times \vec{F}_{imp} \Delta t = I_2 \dot{\theta}_2^+ - I_2 (\dot{\theta}_1^- + \dot{\theta}_2^-) \quad (13)$$

where Δt is the short interval of time over which the impulsive force and impulsive moment act, and \vec{v}_2^+ , \vec{v}_2^- and \vec{r}_2 are given by the expressions - noting that the cart velocity is always going to be zero during this process (i.e. the cart can be treated as a fixed pin joint)-

$$\vec{v}_2^+ = d_2 \dot{\theta}_2^+ (-S_{12} \vec{i} + C_{12} \vec{j}) \quad (14)$$

$$\vec{v}_2^- = -[l_1 \dot{\theta}_1^- S_1 + d_2 (\dot{\theta}_1^- + \dot{\theta}_2^-) S_{12}] \vec{i} + [l_1 \dot{\theta}_1^- C_1 + d_2 (\dot{\theta}_1^- + \dot{\theta}_2^-) C_{12}] \vec{j} \quad (15)$$

$$\vec{r}_2 = -d_2 (C_{12} \vec{i} + S_{12} \vec{j}) \quad (16)$$

By substituting (12), (14), (15) and (16) into (13), we get

$$\dot{\theta}_2^+ = \dot{\theta}_2^- + \left(1 + \frac{m_2 l_1 d_2 C_2}{I_2 + m_2 d_2^2} \right) \dot{\theta}_1^- \quad (17)$$

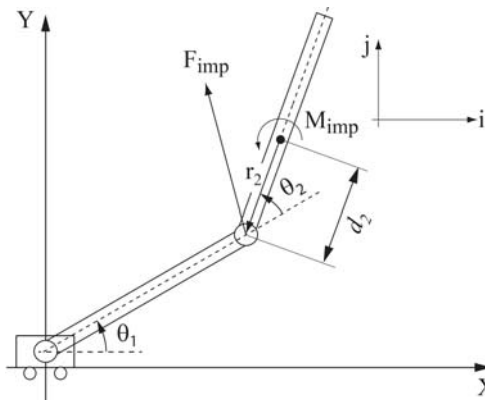

Fig. 3 Effect of suddenly stopping the first link of DIPIC

Since there is no change in the potential energy of the second link over the Δt time interval, the change in the total energy of the second link is due to the change in its kinetic energy alone, and is equal to

$$\Delta E_2 = KE_2^+ - KE_2^- = \frac{1}{2} (I_2 + m_2 d_2^2) (\dot{\theta}_2^+)^2 - \frac{1}{2} I_2 (\dot{\theta}_1^- + \dot{\theta}_2^-)^2 - \frac{1}{2} m_2 \left[l_1^2 (\dot{\theta}_1^-)^2 + 2 l_1 d_2 \dot{\theta}_1^- (\dot{\theta}_1^- + \dot{\theta}_2^-) C_2 + d_2^2 (\dot{\theta}_1^- + \dot{\theta}_2^-)^2 \right] \quad (18)$$

By substituting (17) into (18), the change in second link energy can be expressed as follows:

$$\Delta E_2 = \frac{1}{2} m_2 l_1^2 \left[\frac{m_2 d_2^2 C_2^2}{I_2 + m_2 d_2^2} - 1 \right] (\dot{\theta}_1^-)^2 \quad (19)$$

Since $m_2 d_2^2 C_2^2 < (I_2 + m_2 d_2^2)$, $\Delta E_2 \leq 0$ and $\Delta E_2 = 0$ if only if $\dot{\theta}_1^- = 0$. Clearly, the total energy of the second link decreases whenever the first link is suddenly stopped.

B. Rest-to-Rest Maneuver of the First Link

Consider a maneuver in which the first joint starts from rest and is brought back to rest through the application of a braking torque. Taking into account the loss of energy due to sudden stopping, given by (19), the net work done on the second link due to the rest-to-rest maneuver can be computed as follows:

$$\Delta E_2 = \int F l_1 d\theta_1 + \frac{1}{2} m_2 l_1^2 \left[\frac{m_2 d_2^2 C_2^2}{I_2 + m_2 d_2^2} - 1 \right] (\dot{\theta}_1^-)^2 \geq \int F l_1 \dot{\theta}_1 dt - \frac{1}{2} m_2 l_1^2 (\dot{\theta}_1^-)^2 \quad (20)$$

where F is given by the expression in (8). If we choose to impose the constraint

$$d_2 (\ddot{\theta}_1 + \ddot{\theta}_2) C_2 - d_2 (\dot{\theta}_1 + \dot{\theta}_2)^2 S_2 + g C_1 = k_1 l_1 \ddot{\theta}_1, \quad k_1 > 0 \quad (21)$$

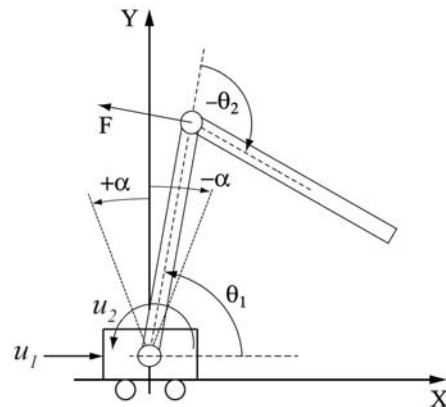

Fig. 4 Rest-to-rest maneuver of the first link while the cart is held fixed at the origin

We get from (8), (20) and (21)

$$\begin{aligned} \Delta E_2 &\geq l_1 \int F \dot{\theta}_1 dt - \frac{1}{2} m_2 l_1^2 (\dot{\theta}_1^-)^2 \\ &= l_1 \int m_2 \left[(1 + k_1) l_1 \ddot{\theta}_1 \right] \dot{\theta}_1 dt - \frac{1}{2} m_2 l_1^2 (\dot{\theta}_1^-)^2 \\ &= \left[\frac{1 + k_1}{2} \right] m_2 l_1^2 \int 2 \dot{\theta}_1 \ddot{\theta}_1 dt - \frac{1}{2} m_2 l_1^2 (\dot{\theta}_1^-)^2 \\ &= \left[\frac{1 + k_1}{2} \right] m_2 l_1^2 (\dot{\theta}_1^-)^2 - \frac{1}{2} m_2 l_1^2 (\dot{\theta}_1^-)^2 \\ &= \frac{1}{2} k_1 m_2 l_1^2 (\dot{\theta}_1^-)^2 > 0 \end{aligned} \quad (22)$$

Clearly, as we illustrated above, the net energy of the second link will increase if we apply the rest-to-rest maneuver procedure.

It is important to note that at any time during a rest-to-rest maneuver, while the first link is still in motion, it is possible to compute:

- E_2 from the values of \dot{x} , θ_1 , $\dot{\theta}_1$, θ_2 , and $\dot{\theta}_2$.
- Energy loss that would result from stopping the first link instantaneously, using (19).

When the difference of the energy values in (a) and (b) is equal to E_{2T} , the motion of the first link can be quickly stopped to have $E_2 \approx E_{2T}$.

IV. INPUT CONTROLLERS CALCULATIONS

The swing-up control algorithm depends mainly on two cases in which the controller will keep switching between them until E_2 reaches approximately E_{2T} level. These two cases are as follows:

A. Case I

The cart is constantly hold fixed by the force u_{1b} while the first link is driven by the controlling torque u_{2c} . In order to bring the velocity of the cart to zero and hold it fixed, we consider braking action that results in exponential decay of the motion of the cart to zero. Thus, we assume

$$\dot{x} = -k_2 \dot{x}, \quad k_2 > 0 \quad (23)$$

where k_2 is a positive constant that will control the rate of decay \dot{x} . Meanwhile, the first link is driven by a torque that satisfies the constraint illustrated in (21). Hence, to compute the control inputs, u_{1b} and u_{2c} , required for this process, we multiply (1) with the inverse of inertia matrix to obtain

$$\ddot{q} = A^{-1}(q)U - A^{-1}(q)[B(q, \dot{q}) + G(q)] \quad (24)$$

where

$$A^{-1}(q) = \begin{bmatrix} a_{11}^{-1} & a_{12}^{-1} & a_{13}^{-1} \\ a_{12}^{-1} & a_{22}^{-1} & a_{23}^{-1} \\ a_{13}^{-1} & a_{23}^{-1} & a_{33}^{-1} \end{bmatrix} = \frac{1}{\det[A(q)]} \begin{bmatrix} a_{22}a_{33} - a_{23}^2 & -(a_{12}a_{33} - a_{13}a_{23}) \\ -(a_{12}a_{33} - a_{13}a_{23}) & a_{11}a_{33} - a_{13}^2 \\ a_{12}a_{23} - a_{13}a_{22} & -(a_{11}a_{23} - a_{12}a_{13}) \\ a_{12}a_{23} - a_{13}a_{22} & -(a_{11}a_{23} - a_{12}a_{13}) \\ a_{11}a_{22} - a_{12}^2 & \end{bmatrix} \quad (25)$$

$$\det[A(q)] = a_{11}(a_{22}a_{33} - a_{23}^2) - a_{12}(a_{12}a_{33} - a_{13}a_{23}) + a_{13}(a_{12}a_{23} - a_{13}a_{22}) \quad (26)$$

or (24) can be expressed as follows:

$$\begin{bmatrix} \ddot{x} \\ \ddot{\theta}_1 \\ \ddot{\theta}_2 \end{bmatrix} = \begin{bmatrix} a_{11}^{-1}u_1 + a_{12}^{-1}u_2 \\ a_{12}^{-1}u_1 + a_{22}^{-1}u_2 \\ a_{13}^{-1}u_1 + a_{23}^{-1}u_2 \end{bmatrix} + \begin{bmatrix} h_1 \\ h_2 \\ h_3 \end{bmatrix} \quad (27)$$

where

$$\begin{bmatrix} h_1 \\ h_2 \\ h_3 \end{bmatrix} = -A^{-1}(q)[B(q, \dot{q}) + G(q)] \quad (28)$$

By substituting the three equations in (27) into (21) and (23) and solving for the control inputs u_1 and u_2 (for this case the names will be u_{1b} and u_{2c} , respectively) we will get

$$u_{1b} = \frac{N_1 + N_2}{N_3 + N_4} \quad (29)$$

$$u_{2c} = \frac{-1}{a_{12}^{-1}}(k_2 \dot{x} + h_1 + a_{11}^{-1}u_{1b}) \quad (30)$$

where

$$N_1 = d_2 C_2 (h_2 + h_3) - d_2 (\dot{\theta}_1 + \dot{\theta}_2)^2 S_2 + g C_1 - k_1 l_1 h_2$$

$$N_2 = \frac{[k_1 l_1 a_{22}^{-1} - d_2 C_2 (a_{22}^{-1} + a_{23}^{-1})](k_2 \dot{x} + h_1)}{a_{12}^{-1}}$$

$$N_3 = k_1 l_1 a_{12}^{-1} - d_2 C_2 (a_{12}^{-1} + a_{13}^{-1})$$

$$N_4 = -\frac{a_{11}^{-1}}{a_{12}^{-1}} [k_1 l_1 a_{22}^{-1} - d_2 C_2 (a_{22}^{-1} + a_{23}^{-1})]$$

B. Case II

The first link will brake suddenly, after moving as we mention in case I, using an exponential decay torque u_{2b} . In order to achieve that, we assume

$$\ddot{\theta}_1 = -k_3 \dot{\theta}_1, \quad k_3 > 0 \quad (31)$$

where k_3 is a positive constant that will control the rate of decay $\dot{\theta}_1$. In the meantime, the cart continues to be hold by the force u_{1b} . Thus, we consider again the condition (23). Hence, to compute the control inputs, u_{1b} and u_{2b} , required for this process, we substitute the three equations in (27) into (23) and (31) and solve for the control inputs u_1 and u_2 (for this case the names will be u_{1b} and u_{2b} , respectively) we will get

$$u_{1b} = \frac{-a_{12}^{-1}(k_3 \dot{\theta}_1 + h_2) + a_{22}^{-1}(k_2 \dot{x} + h_1)}{(a_{12}^{-1})^2 - a_{11}^{-1}a_{22}^{-1}} \quad (32)$$

$$u_{2b} = \frac{-1}{a_{12}^{-1}}(k_2 \dot{x} + h_1 + a_{11}^{-1}u_{1b}) \quad (33)$$

V. ALGORITHM FOR SWING-UP CONTROL

A three step algorithm is proposed for swing-up control of DIPC followed by asymptotic stabilization of the desired equilibrium. These steps are as follows:

1. Initialization

- Linearize the dynamic equations of the DIPC in (1) about the desired equilibrium $(x, \dot{x}, \theta_1, \dot{\theta}_1, \theta_2, \dot{\theta}_2) = (0, 0, \pi/2, 0, 0, 0)$.
- Using the model of the linearized system, design a linear controller to render the desired equilibrium of DIPC locally asymptotically stable. Let R_A define the region of attraction of the desired equilibrium.
- Choose a small angle α , $\alpha > 0$ such that the configuration $(x, \dot{x}, \theta_1, \dot{\theta}_1, \theta_2, \dot{\theta}_2)$ lies always in R_A .

2. Swing-up control of the first link

Drive the first link from its initial configuration to any configuration that satisfies $(\pi/2 - \alpha) \leq \theta_1 \leq (\pi/2 + \alpha)$,

$\dot{\theta}_1 = 0$. In the same time, drive the cart from its initial configuration to $(x, \dot{x}) = (0, 0)$, as shown in Fig. 4.

3. Swing-up control of the second link

- Conduct rest-to-rest maneuvers of the first link about the vertically upright configuration with θ_1 satisfying $(\pi/2 - \alpha) \leq \theta_1 \leq (\pi/2 + \alpha)$, meanwhile, the cart is hold fixed at the origin. As we discussed in section III, E_2 level will increase at each rest-to-rest maneuver. In particular, the following procedure will be adopted: The cart and the first link will be hold fixed using the control inputs in (32) and (33), respectively. To initiate the motion of the first link in the counterclockwise direction, the control inputs (29) and (30) will be used when $u_{2c} > u_{2b}$. Similarly, to initiate the motion of the first link in the clockwise direction, the control inputs (29) and (30) will be used when $u_{2c} < u_{2b}$. As the first link approaches the boundary of the interval $[(\pi/2 - \alpha), (\pi/2 + \alpha)]$, the control inputs (32) and (33) will be invoked in order to stop the first link and keep the cart hold.
- Terminate the rest-to-rest maneuvers with $E_2 \approx E_{2T}$.

From our discussion in section III, we know that this can be accomplished by monitoring the states of DIPC.

4. Stabilization

With $(\pi/2 - \alpha) \leq \theta_1 \leq (\pi/2 + \alpha)$, $\dot{\theta}_1 = 0$, $(x, \dot{x}) = (0, 0)$, and $E_2 \approx E_{2T}$, the second link will behave like a pendulum. When the second link reaches the highest potential energy, the DIPC configuration will be inside R_A . Invoke the linear controller, which is designed in the first step of the algorithm, to stabilize the desired equilibrium.

VI. NUMERICAL SIMULATIONS

For the simulation of the algorithm we have selected the kinematic and dynamic parameters of DIPC from Rubi *et al.* [3] because it has experimental results, noting that the changes of some values are due to the inclusion of the lumped masses on the joints:

$$\begin{aligned} m_0 &= 1.1 \text{ kg}, & d_1 &= 0.312 \text{ m} \\ m_1 &= 0.2 \text{ kg}, & d_2 &= 0.237 \text{ m} \\ m_2 &= 0.1 \text{ kg}, & I_1 &= 0.0028392 \text{ kg.m}^2 \\ l_1 &= 0.39 \text{ m}, & I_2 &= 0.00166427 \text{ kg.m}^2 \\ l_2 &= 0.395 \text{ m}, & & \end{aligned}$$

For these parameters, E_{2T} was evaluated to be 0.615087 J. The gains are selected to be: $k_1 = 1$, $k_2 = 1$, $k_3 = 1000$. As a part of the initialization (first step of the algorithm), a linear controller is designed to stabilize the desired equilibrium. Through repeated simulations the maximum value for α are found to be 0.2 rad. The initial configuration for DIPC is chosen to be

$$(x, \dot{x}, \theta_1, \dot{\theta}_1, \theta_2, \dot{\theta}_2) = (0, 0, 1.45, 0, -2\pi/3, 0) \quad (34)$$

where the units are radian and radian per second. The choice of initial configuration eliminates the need for the second step

of the algorithm, which is trivial. The simulation results for the third and fourth steps of the algorithm are shown in Fig. 5. The plots show the cart and links states, the control inputs and the energy of the second link.

It can be seen in Fig. 5 that $E_2 \approx E_{2T}$ at $t = 2.36$ sec. After that, the second link reaches its vertically upright configuration at $t = 2.95$ sec and the linear controller is invoked for stabilization. The swing-up control of the second link is achieved over the interval $t \in [0, 2.95]$ sec through a series of rest-to-rest maneuvers separated by periods of time over which the first link is held fixed. Fig. 5 illustrate that E_2 increases for each rest-to-rest maneuver, but remains constant during times when the first link is held fixed. In addition, Fig. 5 shows that the increase of E_2 during each rest-to-rest maneuver is achieved through positive work done by the first link followed by energy loss due to braking. During braking, the control inputs peak, but the peak inputs act over a short interval of time. This is expected since the braking inputs are impulsive in nature due to the choice of a large value of gain k_3 . Despite its impulsive nature, the maximum of force done on the cart is 22.3 N which is comparable to 23 N required by the algorithm proposed by [3]. The maximum cart travel in our approach reaches 0.15 m, and this happened only in the stabilization process. Comparing this distant to that proposed in [3] we find it crossed 0.3 m. Moreover, the maximum torque required at the first joint is 6.35 N.m which can easily be supplied by a motor used for a system with this kinematic and dynamic parameters.

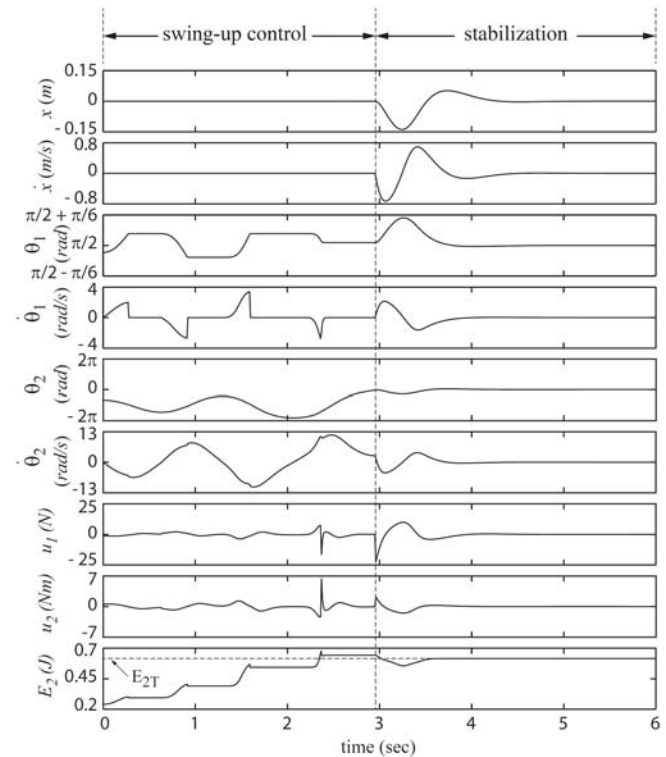

Fig. 5 Plot of DIPC states, control inputs, and energy of second link

It is worth to mention that although the inputs we required in our algorithm are impulsive in nature, they will be limited

to peak torques of the motor and not the maximum continuous torque. The peak torque of a motor is greater than the maximum continuous torque by a factor that varies from motor to motor. This factor can be between 2 to 10, and is equal to 4 for a specific example worked out in the Handbook of Electric Motors [30].

VII. CONCLUSION

This paper presents a new solution to the swing-up control of DIPC. The solution is based on bringing the cart from its initial configuration to the origin and hold it fixed there during the swing-up time. At the same time, the first link is taken from its initial configuration to the upright position. Then, it makes a series of rest-to-rest maneuvers with small amplitude of oscillation. The rest-to-rest maneuvers are designed in a way to increase the energy of the second link in each move based on principles of work-energy and impulse and momentum. Once the energy of the second link becomes approximately equal to its maximum potential energy, DIPC configuration enters the neighborhood of the desired equilibrium at which stabilization is achieved using linear controller. Simulation results are presented to demonstrate the feasibility of the proposed approach. Moreover, this work can be extended in the future to swing-up other benchmark system. In fact, the algorithm has the potential to solve the swing-up problem of n -link system with $(n-1)$ actuators.

REFERENCES

- [1] T. Albahkali, R. Mukherjee, and T. Das, "Swing-Up Control of the Pendubot: An Impulse-Momentum Approach," *IEEE Trans. On Robotics*, vol. 25, No. 4, August 2009, pp. 975–982.
- [2] T. Albahkali, "An Impulse-Momentum Approach to Control of a Class of Underactuated Mechanical Systems," Ph.D thesis, Dept. Mech. Eng., Michigan State Univ., 2009.
- [3] J. Rubi, A. Rubio, and A. Avello, "Swing-Up Control Problem for a Self-Erecting Double Inverted Pendulum," *IEE Proc. –Control Theory Appl.*, Vol. 149, No. 2, March 2002, pp. 169–175.
- [4] C. W. Tao, J. Taur, J. H. Chang, and S.-F. Su., "Adaptive Fuzzy Switched Swing-Up and Sliding Control for Double-Pendulum-and-Cart System," *IEEE Trans. On Systems, Man, and Cybernetics Part B: Cybernetics*, Vol. 40, No. 1, February 2010, pp. 241–252.
- [5] W. Zhong, and H. Rock, "Energy and Passivity Based Control of the Double Inverted Pendulum on a Cart," Proc. IEEE Inter. Conf. on Control Applications, September 2001, Mexico, pp. 896-901.
- [6] M. Takahashi, T. Narukawa, and K. Yoshida, "Intelligent Stabilization Control to An Arbitrary Equilibrium Point of Double Pendulum," *Proc. American Control Conference*, Boston, Massachusetts, June 2004, pp. 5772-5777.
- [7] A. Bradshaw and J. Shao, "Swing-Up Control of Inverted Pendulum Systems," *Robotica.*, Vol. 14, pp. 397-405, 1996.
- [8] H. Niemann, J. K. Poulsen, "Design and Analysis of Controllers for a Double Inverted Pendulum," *The Instrumentation, Systems, and Automation Society*, 2005.
- [9] C. -I. Huang, and L. -C. Fu, "Passivity Based Control of the Double Inverted Pendulum Driven by a Linear Induction Motor," *Proc. IEEE Conf. Control Appl.*, Vol. 2, August 2003, pp. 797–802.
- [10] K. Graichen, M. Treuer, M. Zeitz, "Swing-Up of the Double Pendulum on a Cart by Feedforward and Feedback Control with Experimental Validation," *Automatica*, No. 43, 2007.
- [11] K. J. Astrom, and K. Furuta, "Swinging Up a Pendulum by Energy Control," *IFAC 13th World Congress*, San Francisco, California, 1996.
- [12] X. Xin, "Analysis of the Energy Based Swing-Up Control for a Double Pendulum on a Cart," *Proc. Of 17th IFAC World Congress*, pp. 4828-4833.

- [13] I. Fantoni, R. Lozano and M. W. Spong, "Energy based control of the pendubot," *IEEE Trans. Automat. Contr.*, Vol. 44, No. 4, pp. 725-729, 2000.
- [14] K. S. Fu, R. C. Gonzalez and C. S. G. Lee, *Robotics: control, sensing, vision and intelligence*, McGraw-Hill, Inc., 1987.
- [15] M. W. Spong and D. J. Block, "The pendubot: A mechatronic system for control research and education," in *34th IEEE Conf. Decision and Control*, New Orleans, pp. 555-556, 1995.
- [16] A. S. Shiriaev and O. Kolesnichenko, "On Passivity Based Control for partial Stabilization of Underactuated Systems," in *39th IEEE Conf. Decision and Control*, 2000.
- [17] H. Arai and S. Tachi, "Position Control of a Manipulator with Passive Joints Using Dynamic Coupling," *IEEE Trans. On Robotics and Automation*, vol.7, pp.528-534, 1991.
- [18] L. T. Aguilar, I. Boiko, L. Fridman and R. Iriate, "Generation of periodic motions for underactuated mechanical system via second-order sliding-modes," *American Control Conference*, pp. 5396-5400, 2006.
- [19] Y. Aoustin, D. T. Romero, C. Chevallereau and S. Aubin, "Impulsive Control for a Thirteen-Link Biped," *IEEE International Workshop on Advanced Motion Control*, Istanbul, Turkey, pp. 439-444, 2006.
- [20] J. Chudoung and C. Beck, "The Minimum Principle for Deterministic Impulsive Control Systems," *40th IEEE Conference on Decision and Control*, Orlando, FL, pp. 3569-3574, 2001.
- [21] L. Freidovich, A. Robertsson, A. Shiriaev and R. Johansson, "Periodic Motions of the Pendubot via Virtual Holonomic Constraints: Theory and Experiments," *Automatica*, Vol. 44, pp. 785-791, 2008.
- [22] E. G. Gilbert and G. A. Harasty, "A Class of Fixed-Time Fuel-Optimal Impulsive Control Problems and an Efficient Algorithm for Their Solution," *IEEE Transactions on Automatic Control*, Vol.16, No.1, pp. 1-11, 1967.
- [23] O. Kolesnichenko and A. S. Shiriaev, "Partial Stabilization of Underactuated Euler-Lagrange Systems via a Class of Feedback Transformations," *Systems and Control Letters*, Vol.45, pp. 121-132, 2002.
- [24] X. -Z. Lai, J. -H. She, S. X. Yang and M. Wu, "Unified Treatment of Motion Control of Underactuated Two-Link Manipulators," *IEEE/RSJ Conference on Intelligent Robots and Systems*, pp. 574-579, 2006.
- [25] J. -L. Menaldi, "The Separation Principle for Impulse Control Problems," *American Mathematical Society*, Vol.82, No.3, pp.439-445, 1981.
- [26] Y. Orlov, L. T. Aguilar, L. Acho, and A. Ortiz, "Swing up and Balancing Control of Pendubot via Model Orbit Stabilization: Algorithm Synthesis and Experimental Verification," *IEEE Conference on Decision and Control*, pp.6138-6143, 2006.
- [27] T. Pavlidis, "Stability of Systems Described by Differential Equations Containing Impulses," *IEEE Transactions on Automatic Control*, Vol.12, No.1, pp.43-45, 1967.
- [28] M. W. Spong, "Underactuated Mechanical Systems," *Control Problems in Robotics and Automation*, B. Siciliano and K. P. Valavanis Eds., LNCIS, Vol.230, pp.135-150, Springer Verlag, London, 1998.
- [29] J. Sun, Y. Zhang and Q. Wu, "Less Conservative Conditions for Asymptotic Stability of Impulsive Control Systems," *IEEE Transactions on Automatic Control*, Vol.48, No.5, pp.829-831, 2003.
- [30] H. A. Toliyat and G. B. Kliman, "Handbook of Electric Motors," Second Edition, Marcel Dekker, Inc., New York, NY, pp.354, 2004.
- [31] Z. Wang, Y. Chen and N. Fang, "Minimum-time Swing-up of a Rotary Inverted Pendulum by Iterative Impulsive Control," *American Control Conference*, pp.1335-1340, 2004.
- [32] S. Weibel, G. W. Howell and J. Baillieul, "Control of Single-Degree-of-Freedom Hamiltonian Systems with Impulsive Inputs," *IEEE Conference on Decision and Control*, Kobe, Japan, pp.4661-4666, 1996.
- [33] G. Xie and L. Wang, "Necessary and Sufficient Conditions for Controllability and Observability of Switched Impulsive Control Systems," *IEEE Transactions on Automatic Control*, Vol.49, No.6, pp.960-966, 2004.
- [34] J. Hauser and R. M. Murray, "Nonlinear controllers for nonintegrable systems: the acrobot example," *Proceedings of American Control Conference*, San Diego, California, May 1990, pp. 669–671.
- [35] A. Ohsumi, T. Izumikawa, "Nonlinear Control of Swing-Up Stabilization of an Inverted Pendulum," *Proc. Of 34th Conf. on Decision and Control*, New Orleans, LA, December 1995, pp. 3873-3880.