

Development of a Novel Pneumatic Hybrid Engine

Yu-Ta Shen, Yean-Ren Hwang

Abstract—Although electrical motors are still the main devices used in vehicular exhaust comprises more than 95 percent of the air pollution in Taiwan's largest city, Taipei. On average, all commuters in Taipei travel 13.6 km daily, while motorcycle commuters travel 12.2 km. The convenience and mobility of motorcycles makes them irreplaceable in Taiwan city traffic but they add significantly to air pollution problems. In order to improve air pollution conditions, some new types of vehicles have been proposed, such as fuel cell driven and hybrid energy vehicles. In this study, we develop a model pneumatic hybrid motorcycle system and simulate its acceleration and mileage (km/L) performance. The results show that the pneumatic hybrid motorcycle can improve efficiency.

Keywords—vehicular, exhaust, air pollution, pneumatic, hybrid, motorcycle.

I. INTRODUCTION

Taiwan's heavy traffic volume and high concentration of industry makes air pollution one of the most alarming problems in the country. The Environmental Protection Administration (EPA) reported in 2007 that there were about 2-3 registered factories and more than 450 motor vehicles for every square kilometer in the Taiwan area. According to the EPA, vehicular exhaust comprises more than 95 percent of the air pollution in Taipei, Taiwan's largest city [1]. On average, all commuters travel 13.6 km daily in Taipei City, while motorcycle riders need only travel 12.2 km. This difference in trip distance increases the dependence on the motorcycle [2]. The main source of air pollution in Taiwan's cities is the waste gas exhaust from scooters, especially the large number of two-stroke engine scooters [3].

One possible way to reduce air pollution is to use more of the hybrid electric vehicles now available in the car market. Automakers are aiming to develop zero-pollution engines (green energy) in future. There are many new types of vehicles under development, including fuel cell [4-5] and hybrid energy driven vehicles. Hybrid energy includes the internal combustion engine (ICE) and electrical or pneumatic motors. Another option is the Pneumatic-Hybrid Electric Vehicle, which uses a two-stroke compressed air engine for starting, acceleration and uphill climbs. The car switches to an electric motor when its speed reaches 20-25 km/h.

Yu-Ta Shen is with the Department of Mechanical Engineering, National Central University, Chung-Li, Taiwan 320, R.O.C. (phone:+886-3-4267342; fax: +886-3-4254501; e-mail: 93323095@cc.ncu.edu.tw).

Yean-Ren Hwang is with the Department of Mechanical Engineering, National Central University, Chung-Li, Taiwan 320, R.O.C.

Some researchers are also studying a possible hybrid system for motorcycles.

Huang *et al.* [6-8] has investigated other types of hybrid pneumatic power vehicles and developed a pneumatic motor combined with an ICE. The hybrid concept is to utilize an internal combustion engine connected to a compressor to propel the vehicle and refill the air tank. Their main differences from hybrid gas-electricity engines are that an air compressor replaces the generator, a pneumatic motor replaces the electric motor, a high-pressure air tank replaces the battery, and flow work replaces the electrical energy. The exhaust gas from the ICE can be merged with the compressed air to increase the pressure and temperature. Previous pneumatic hybrids [6-7] have been designed to utilize an air motor and combustion engine in a hybrid series. The problem of this pneumatic hybrid are needed to mount extra device, such as air motor, air compressor, on the motorcycle and these kinds of pneumatic hybrid conceptions need large space for motorcycle and would add the weight to affect the efficiency. In this study, we develop a mathematical model of a pneumatic hybrid motorcycle and carry out a simulation through MATLAB®. Our pneumatic motorcycle engine design uses the two cylinder structure shown in Figure 1. One cylinder is the conventional internal combustion cylinder and the other is an air-powered cylinder. The proposed pneumatic hybrid engine combines these two capabilities (air motor and internal combustion engine) into one engine. It becomes more convenient because there is no large space required on the motorcycle. This new pneumatic engine has advantages, such like the low cost of implementation, the expected lower mass added to the vehicle, higher reliability and long term durability. The design purpose is to simulate the drivability of this motorcycle. The motorcycle's performance, primarily related to the acceleration and speed needed to ride safely in ordinary city traffic, is simulated. The travelling range of the motorcycle can be mathematically modeled to understand the effects of changing parameters such as the air tank capacity, as well as all other aspects of the motorcycle design.

II. PNEUMATIC HYBRID ENGINE CONCEPT

Fig.1 shows a conceptual drawing of the pneumatic hybrid engine. There are two cylinders which are connected to one camshaft to produce torque. One is a conventional internal combustion cylinder (on the right side of the engine) and the other is a pneumatic cylinder (on the left side of the engine) which has three valves. One of them, called the charging valve, is actuated electrically and connected to the air tank.

This new pneumatic hybrid engine can be separated into two operation modes: pumping charging and motoring.

The pumping charge is a crucial operation of the pneumatic hybrid engine. As the motorcycle decelerates, the road produces torque on the wheels turning the powertrain until finally reaching the engine. The engine then acts as a compressor to pump air from the charging valve into the air tank. The braking torque as well as the mass of compressed air stored in the air tank can be continuously adjusted by varying the charging and exhausting timings of the charging valve.

As we know, internal combustion engines cannot be reversed to create chemical energy when yielding negative torque, such as in braking situations. The energy is consumed as heat caused by friction. However, the hybrid pneumatic engine takes advantage of this negative torque when a motorcycle is braking, converting the kinetic energy into pressurized gas in the air tank. Fig. 2 displays an idealized P-V diagram (TDC: Top Dead Center, BDC: Bottom Dead Center).

At point 1 in the two-stroke cycle both the tank and cylinder are at ambient temperature and pressure and the cylinder is at bottom dead center. At point 2, the cylinder compresses slightly and the charge valve is opened. At point 3, the temperature and pressure reach equilibrium, because the tank is now a part of the system, assuming the volume of the air tank is much larger than the volume of the cylinder. At point 4 the cylinder compresses more and the charge valve is closed. At point 5, the cylinder compresses to top dead center. Finally, at point 6 the charge valve is opened and the remaining compressed air is pushed into the air tank. The system then returns to its initial state only with the air tank containing the compressed air. Fig. 3 illustrates the pressure in the tank with respect to the number of compression revolutions (Rev.) and various tank sizes.

The motoring operation mode is used to propel the motorcycle forward starting from the engine in idle. If the engine is not completely stop, the motoring will not operate. In this mode, the high pressure air pushes the piston down to produce output torque that is adequate to propel the motorcycle and avoid the engine operating under low speed conditions. The size of the air tank is limited by the motorcycle's space. Since the motoring operation mode requires rapid acceleration, the timing of the opening and closing of the charging valve is important, because it determines when to smoothly switch to the combustion engine before the air runs out completely. The pneumatic hybrid engine produces torque using high pressure air to propel the motorcycle. If the capacity of the air tank is adequate for the motor, the opening timings of the charging valve ensure that the mechanical energy can be converted to the crankshaft. The motoring cycle consists of three steps: cylinder charging, expansion and exhausting. The full cycle is completed within one crankshaft revolution. Fig.4 displays a P-V diagram of the pneumatic motoring cycle. The timing of the charging valve means that it is open from points 1 to 3.

The pressure in the cylinder can be increased by discharging the air tank between points 1 and 2.

The pressure remains at a constant value from points 2 to 3 (assuming that the air tank is larger than the cylinder).

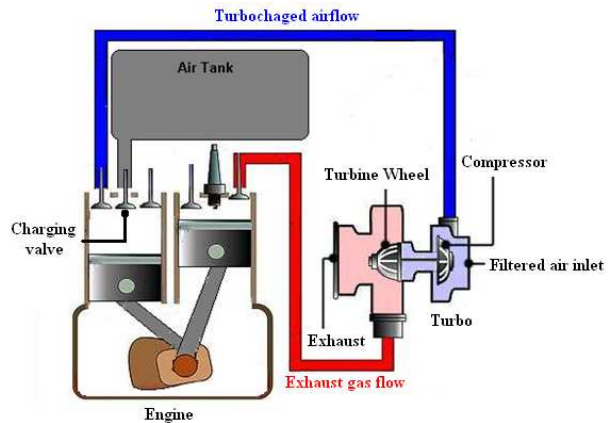

Fig.1 Conceptual drawing of the pneumatic hybrid engine

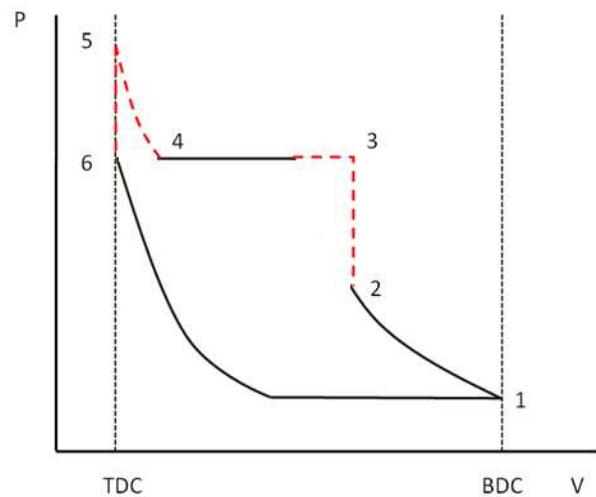

Fig. 2 P-V diagram of pneumatic pump operation

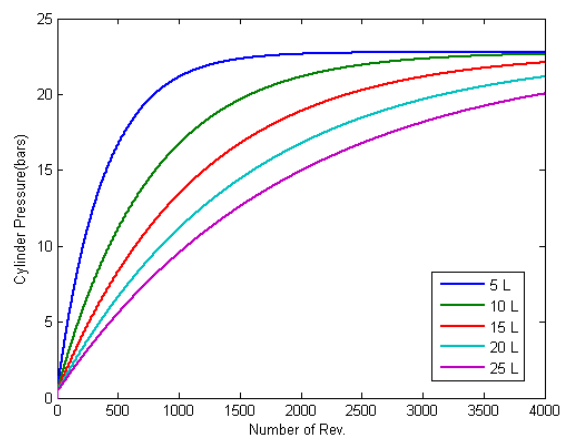

Fig. 3 Air compression pumping

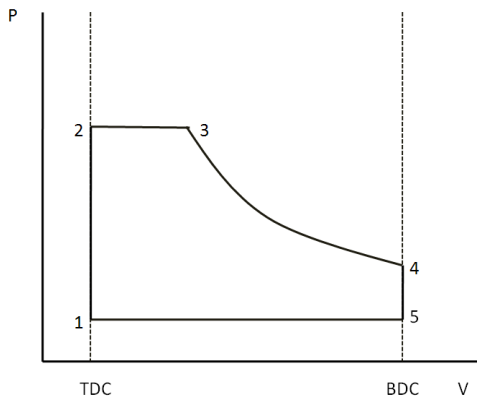

Fig. 4 P-V diagram for the pneumatic motoring cycle

The position at point 3 can be varied by choosing the timing of the charging valve closure. The expansion, from points 3 to 4 with the charging valve closure, will produce torque to the crankshaft. The closing timings of the charging valve are designed so that the torque value is significant enough to propel the motorcycle. It is important to determine the torque needed for this purpose and what the closure timing should be. Eventually, the air will be expelled from the exhaust pipe (from points 4 to 5). Motoring output torque calculations are described below.

The torque can be described as

$$Torque(\theta) = \frac{\pi}{4} B^2 R_{ck} [P_c(\theta) (\sin(\theta) + \cos(\theta) \tan(\frac{\sin^{-1}(R_{ck} \sin(\theta))}{L}))] \quad (1)$$

where $B=0.054$ m, $R_{ck}=0.0272$ m, $L=0.144$ m, Initial tank pressure=23 bars. Initial tank temperature=300 K.

III. PNEUMATIC HYBRID MOTORCYCLE MODELING AND SIMULATION RESULTS

Predicted motorcycle performance is important. The results of changes, such as the weight of the motorcycle, affecting the performance and range can be predicted through simulation with different aspects, such as motoring power, gear ratio, weight, and so on. Calculation of the tractive effort is the first step in performance modeling. This force propelling the motorcycle forward is transmitted to the ground through the drive wheels. Fig. 5 shows the force acting on a motorcycle moving along a slope.

The total tractive effort is the sum of all these forces [13], assuming no-slipping condition

$$F_{te} = F_{rr} + F_{ad} + F_{hc} + F_{la} + F_{wa} \quad (2)$$

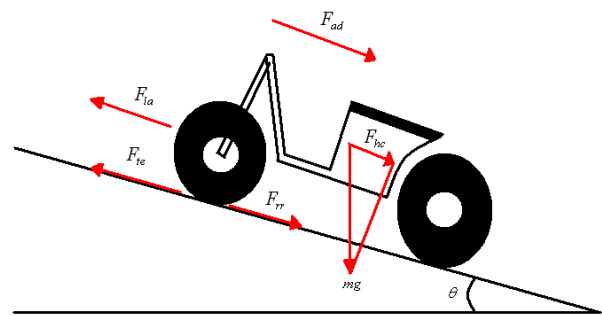

Fig. 5 Force acting on a motorcycle moving along a slope

where F_{rr} is the rolling resistance force; F_{ad} is the aerodynamic drag; F_{hc} is the uphill climbing force; F_{la} is the force required to give linear acceleration; F_{wa} is the force required to give angular acceleration to the rotating engine.

In order to simulate the pneumatic hybrid engine it is necessary to map the brake specific fuel consumption (BSFC), as a measure of fuel efficiency within a shaft reciprocating engine of the ICE. The results of BSFC allow for direct comparison of the fuel efficiency of different reciprocating engines. A contour plot of the efficiency of an existing 125 c.c. four-stroke gasoline engine (shown in Fig. 6) is considered in this study [7], where units are in grams of petrol per kilowatt-hour (g/kWh). As shown, at the optimal operation point, the output power is 3.8 kW, the output torque is 9.5 Nm and the brake specific fuel consumption is 278 g/kWh at 4000 rpm. The system is kept operating at its optimized fuel transformation efficiency. The thick red line in Figure 10 indicates the engine torque at full-throttle, which can be described by a polynomial for the purpose of simulation.

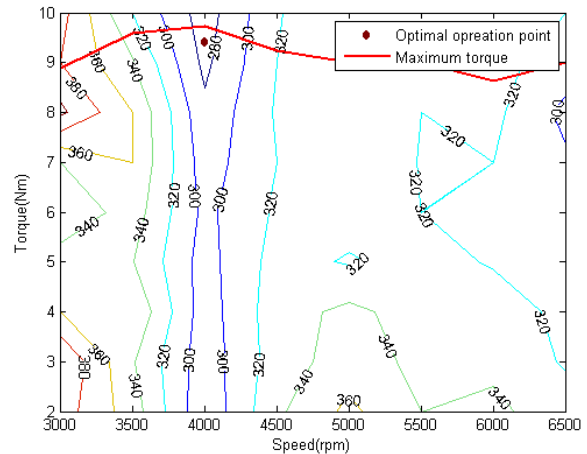

Fig. 6 Brake specific fuel consumption (grams of petrol per kilowatt-hour, g/kWh) for a 125 cc four-stroke engine

The driving cycle is indicated by vehicle speed versus time graph that must be followed by the driver. This information can allow us to simulate the pneumatic hybrid engine and to determine whether or not this hybrid engine is efficient and has the ability to drive on the road. UDDC driving cycles is simulated during the model testing:

UDDC: The Urban Dynamometer Driving Cycle (UDDC) is normally used for light-duty vehicles. This is an American driving cycle standard used to simulate city driving in the United State. The original UDDC speed unit for car simulations is a mile per hour, but this is too fast for a motorcycle. Therefore, we downscale the speed unit to km/h for motorcycle simulations. The down-rated UDDC (DUDDC) is shown in Fig. 7. Figs. 7-8 show the results for the pneumatic hybrid engine. The air pressure in the tank starts the cycle at 20 bars and finishes the cycle at 20 bars. This result ensures that the motorcycle can track the driving cycle without large errors. The results prove that the driving cycle can be followed successfully. The fuel consumption is shown in Table I. It is obvious that the pneumatic hybrid engine lowers fuel consumption with both normal and heavy drivers. The hybrid engine can work successfully to save up to 33% of fuel consumption.

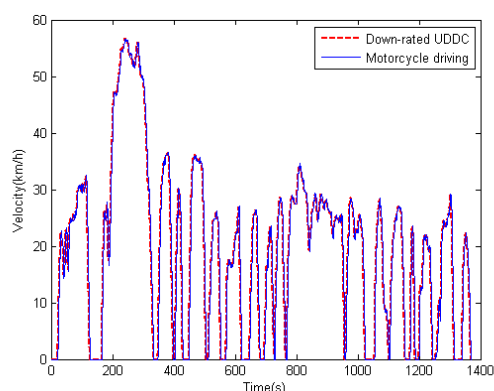

Fig. 7 Pneumatic hybrid engine driving results with down-rated UDDC (DUDDC)

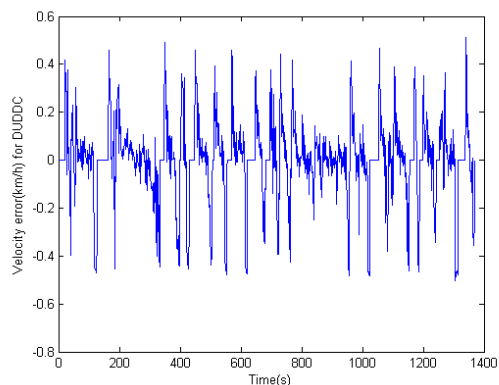

Fig. 8 Velocity error with down-rated UDDC (DUDDC)

TABLE I
 NORMAL DRIVING DRIVING CYCLES RESULT

	Mileage of ICE	Mileage of Hybrid	Fuel Improvement
DUDDC	45 km/L	60 km/L	33%

IV. CONCLUSIONS

A novel engine design for a pneumatic hybrid motorcycle is presented. Compared with previous pneumatic hybrid engines our design does not need extra air motors, compressors, mixing chambers and so on.

The technological features of this system are as follows:

- The pneumatic hybrid engine has two operation modes, pumping and motoring. Previous designs have separated these two operation modes into charging with compressors and air motors but we combine these two operation modes together, so it was not necessary to mount extra devices on the motorcycle.
- No extra space is needed on this pneumatic hybrid motorcycle to add the extra devices. In future, we will test more city driving cycles to confirm this hybrid motorcycle's drivability in the city.

REFERENCES

- [1] Taiwan EPA, <http://www.epa.gov.tw/>;2010.
- [2] Chiu YC, Tzeng G.H, The market acceptance of electric motorcycles in Taiwan experience through a stated preference analysis, Transportation Research Part D 1999;4:127-46.
- [3] Tso C, Chang SY, A viable niche market—fuel cell scooters in Taiwan, Int J Hydrogen Energy2003;28:757–62.
- [4] Wang JH, Chiang, WL, Shu JPH, The prospects: fuel-cell motorcycles in Taiwan, J Power Sources 2000; 86:151–7.
- [5] Lin, B, Conceptual design and modeling of a fuel-cell scooter for urban Asia, J Power Sources 2000; 86: 202–13.
- [6] Huang KD, Tzeng SC, Development of a hybrid pneumatic-power vehicle, Appl Energy 2005;80:47-59.
- [7] Huang KD, Tzeng SC, Ma WP, Chang WC, Hybrid pneumatic-power system which recycles exhaust gas of an internal-combustion engine, Appl Energy 2005;82:117-132.
- [8] Huang KD, Tzeng SC, Chang WC, Energy-saving hybrid vehicle using a pneumatic-power system, Appl Energy 2005;81:1-18.