

Sensitivity Analysis in Power Systems Reliability Evaluation

A.R Alesaadi , M. Nafar and A.H. Gheisari

Abstract—In this paper sensitivity analysis is performed for reliability evaluation of power systems. When examining the reliability of a system, it is useful to recognize how results change as component parameters are varied. This knowledge helps engineers to understand the impact of poor data, and gives insight on how reliability can be improved. For these reasons, a sensitivity analysis can be performed. Finally, a real network was used for testing the presented method.

Keywords—sensitivity analysis, reliability evaluation, power systems.

I. INTRODUCTION

RELIABLE electric power systems serve customer loads without interruptions in supply voltage. Generation facilities must produce enough power to meet customer demand. Transmission systems must transport bulk power over long distances without overheating or jeopardizing system stability. Distribution systems must deliver electricity to each customer's service entrance. In the context of reliability, generation, transmission, and distribution are referred to as functional zones[1].

Transmission systems transport electricity over long distances from bulk power generation facilities to substations that serve subtransmission or distribution systems. Most transmission lines are overhead but there is a growing trend towards the use of underground transmission cable (oil-filled, SF6 filled, extruded dielectric, and possibly superconducting). To increase flexibility and improve reliability, transmission lines are interconnected at transmission switching stations and transmission substations. This improves overall performance, but makes the system vulnerable to cascading failures. A classic example is the Northeastern Blackout of November 9th, 1965, which left an entire region without electricity for many hours[2].

There are several methods to perform reliability evaluation; one of these methods is cutset method. The cutset method can

be applied to systems with simple as well as complex configurations and is a very suitable technique for reliability analysis of power systems. A cutset is a set of components whose failure will cause system failures. A minimal cutset has no proper subset of components whose failure alone will cause system failure. The components of a minimal cutset are in parallel since all of them must fail in order to cause system failure. All minimal cutsets are in series as failure of any one minimal cutset can cause system failure [3]. A cutset containing 'n' components is termed as 'nth order cutset'.

In theory all minimal cutsets of a system must be found. In practice, however, it is not necessary to find all cutsets, as probability of higher order cutsets is negligible as compared to that of lower order cutsets. A good rule of thumb is to consider minimal cutsets up to order n+1 where n is the lowest-order minimal cutset of the system [4]. Since most power systems have at least some first-order minimal cutsets, only first-order and second-order cutsets are considered.

The minimal cutset method is systematic and straightforward and lends itself to either manual or computer computation. An important feature of the method is that system weak points can be readily identified, both numerically and non-numerically, thereby focusing design attention on those sections or components of the system that contribute most to service unreliability. So, in this paper the proposed method is based on minimal cutset approach[5].

In reliability studies, The basic parameters are the probability and frequency of failure at the individual load points, but additional indices can be created from these generic values. The individual load point indices can also be aggregated to produce system indices. These system indices are[6]:

$$\text{Bulk Power Interruption Index (BPII)} = \frac{\sum_k \sum_i L_{ki} \lambda_i}{L_s}$$

$$\text{Bulk Power Energy Curtailment Index (BPECI)} = \frac{\sum_k \sum_i L_{ki} U_i}{L_s}$$

$$\text{Modified Bulk Power Energy Curtailment Index (MBPECI)} = \frac{\sum_k \sum_i L_{ki} U_i}{8760 \times L_s}$$

$$\text{Bulk Power Supply Average Curtailment (BPSAC)} = \frac{\sum_k \sum_i L_{ki} \lambda_i}{\sum_i \lambda_i}$$

$$\text{Average Load Curtailment (ALC)} = \frac{\sum_k \sum_i L_{ki} \lambda_i}{C}$$

-Alireza Alesaadi is with the Islamic Azad University, Kazerun Branch, Kazerun, Iran. (Alesaadi@kau.ac.ir)

-Mehdi Nafar is with the Islamic Azad University, Marvdasht Branch, Marvdasht, Iran (mehdi nafar@miau.ac.ir)

- Amir Hosein Gheisari is with the Islamic Azad University, Fars Science and Research Branch. Marvdasht. Iran.amir.ghesari@fsriau.ac.ir

$$\text{Average Number of Curtailments (ANC)} = \frac{\sum_k \sum_i \lambda_i}{C}$$

$$\text{Average Energy Curtailment (AEC)} = \frac{\sum_k \sum_i L_{ki} U_i}{C}$$

$$\text{Average Duration of Load Curtailments (ADLC)} = \frac{\sum_k \sum_i U_{ki}}{C}$$

where:

λ is permanent forced outage failure rate, r is mean repair time, L_{ki} is load curtailed at bus k due to contingency i . L_s is the total system load. U_i is the mean duration time of contingency i and C is number of output nodes (subtransmission substations).

II. SENSITIVITY ANALYSIS

When examining the reliability of a system, it is useful to recognize how results change as component parameters are varied. This knowledge helps engineers to understand the impact of poor data, and gives insight on how reliability can be improved. For these reasons, a sensitivity analysis can be performed. The sensitivity of a function with respect to a parameter is defined as the partial derivative of the function with respect to that parameter (keeping all other parameters fixed) and represents how the function changes.

Sensitivity analyses are useful for many aspects of system analysis. First, they can be used to test the sensitivity of results to default reliability data. Concern over an uncertain data assumption may be mitigated if results are found to be insensitive to these assumptions. Second, sensitivity results can be used to efficiently calibrate systems to historical reliability data. Last, sensitivity analyses can be used to help anticipate whether certain actions can be expected to have a significant reliability impact on the system. For example, if system BPII is highly sensitive to overhead line failure rates, reducing overhead line failures will probably be an effective strategy for reducing BPII (but not necessarily cost effective).

In general the sensitivity of network reliability indexes due to changing of a reliability parameter is calculated as below:

$$S_{Index} = \frac{\frac{\Delta Index}{Index}}{\frac{\Delta PR_i}{PR_i}}$$

Where PR_i is a parameter of i th element that sensitivity analysis is performed to it (for example: failure rate, mean repair time and...), ΔPR_i is the variations of that parameter.

The *Index* is the numerical value of an index that reliability analysis is performed for it (for example: BPII, BPECI,...), $\Delta Index$ is the variations of that index after changing the purposed parameter.

III. RESULTS

A real network shown in Figure 1 is used for testing the presented method. This network is a part of Iran transmission network (Azarbayjan Transmission and Subtransmission network). This network relatively is an expanded network, it has 15 transmission substations (One 400/230kV, eight 230/132kV and six 230/63kV substations) and 85 subtransmission substations (the number of 132/20kV substation is 52 and 63/20kV is 33). For evaluating the reliability of the purposed network, all components of transmission substations are considered (2477 components including: C.T, Breaker, Arrester and etc). Substations are considered with all details. For example, Fig.2 shows a scheme for one of the substations

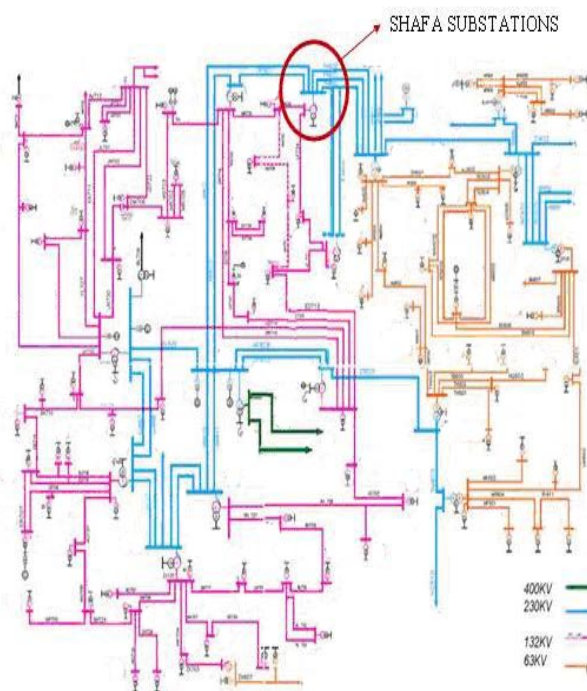

Fig. 1 Single line diagram of the test system

For sensitivity analysis two following are performed:

Case-1: The sensitivity analysis is performed to repair time parameter of three most important elements of network (transformer, transmission line and circuit breakers), because the repair time is more flexible to change in compare with other reliability parameters. To do the sensitivity analysis, the repair time of each element is reduced to 90% of present repair time and the reliability indices are calculated again. Using the related relation the sensitivity index is achieved. The results of sensitivity analysis for this case are shown in Table1, these results show that the reliability indices are more sensitive to repair time of the power transformers. In other words it's advised to decrease the repair time of the transformers (in compare whit other elements) in order to improve the network reliability.

Case-2: In this case, the failure rate of each element is reduced to 90% of present failure rate. The results of sensitivity analysis for this case are shown in Table2; these results show that the reliability indices are more sensitive to failure rate of the overhead lines. In other words it's advised to use more reliable overhead lines for improvement in the network reliability.

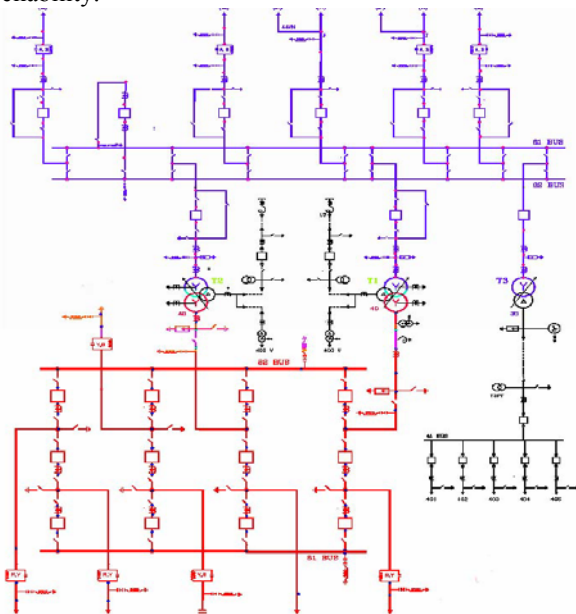

Fig. 2. Single line diagram of a sample substation (the SHAFa substation).

TABLE I
 RESULT OF SENSITIVITY ANALYSIS IN CASE-1

Element Sensitivity	Overhead line	Circuit Breaker	Transformer
S_BPII	2.12%	2.21%	2.43%
S_BPSAC	0.71%	0.73%	0.74%
S_BPECI	0.56%	0.61%	0.6.9%
S_MBPECI	0.56%	0.61%	0.6.9%
S_ANC	1.41%	1.53%	1.78%
S_ALC	2.12%	2.21%	2.43%
S_AEC	0.56%	0.61%	0.6.9%
S_ADLC	0.51%	0.58%	0.62%

TABLE II
 RESULT OF SENSITIVITY ANALYSIS IN CASE-2

Element Sensitivity	Overhead line	Circuit Breaker	Transformer
S_BPII	3.51%	2.94%	3.22%
S_BPSAC	1.84%	1.36%	1.64%
S_BPECI	1.19%	0.82%	0.91%
S_MBPECI	1.19%	0.82%	0.91%
S_ANC	1.45%	1.55%	1.73%
S_ALC	3.51%	2.94%	3.22%
S_AEC	1.19%	0.82%	0.91%
S_ADLC	0.95%	0.88%	0.92%

IV. CONCLUSION

In this paper sensitivity analysis was performed for reliability evaluation of power systems. A real network was used for testing the presented method and results were shown.

V. REFERENCES

- [1] R.Billinton, R.N.Allan; Reliability evaluation of power systems"; Boston Piton books,1984
- [2] P.M. Anderson and S.K. Agarwal; "An improved model for protective-system reliability"; IEEE Trans. On power systems, Sep. 1999, Vol. 41, No.3, pp.422-426.
- [3] P.M. Anderson, G.M. Chintaluri, S.M. Magbuhat and R.F. Ghajar; "An improved reliability model for redundant protective systems – Markov models"; IEEE Trans. On power systems, May 1997, Vol. 12, No.2, pp.573-579.
- [4] J.D. McCalley, W. Fu; "Reliability of special protection systems"; IEEE Trans. On power systems, Nov 1999; Vol. 14, No.4, pp. 1400-1406.
- [5] L.R.C.Ferreira, A. Crossely, R.N. Allan and J. Downes; "The impact of functional integration on the reliability of substation protection and control systems"; IEEE Trans. On power delivery, Jan. 2001, Vol. 16, No. 1, pp.83-88.
- [6] A. Carlos, J.J. Porta and R. Nadira; " An approach for explicitly the protective relaying system in substation reliability evaluation studies" ; IEEE Trans. On power systems, Nov 1999, Vol. 6, No.4, pp.1373-1379