

Performance of Chaotic Lu System in CDMA Satellites Communications Systems

K. Kemih and M. Benslama

Abstract—This paper investigates the problem of spreading sequence and receiver code synchronization techniques for satellite based CDMA communications systems. The performance of CDMA system depends on the autocorrelation and cross-correlation properties of the used spreading sequences. In this paper we propose the uses of chaotic Lu system to generate binary sequences for spreading codes in a direct sequence spread CDMA system. To minimize multiple access interference (MAI) we propose the use of genetic algorithm for optimum selection of chaotic spreading sequences. To solve the problem of transmitter-receiver synchronization, we use the passivity controls. The concept of semipassivity is defined to find simple conditions which ensure boundedness of the solutions of coupled Lu systems. Numerical results are presented to show the effectiveness of the proposed approach.

Keywords—About Chaotic Lu system, synchronization, Spreading sequence, Genetic Algorithm. Passive System

I. INTRODUCTION

COMMUNICATIONS satellites have redefined our world. Satellites and other modern telecommunications networks, together with TV, have now altered the patterns and even many of the goals of modern society. Satellites, for better or worse, have made our world global, interconnected, and interdependent. Worldwide access to rapid telecommunications networks via satellites and cables now creates widespread Internet links, enables instantaneous news coverage, facilitates global culture and conflict, and stimulates the formation of true planetary markets. Satellites change our world and affect our lives [1].

An increasing interest has been recently devoted to the idea of using chaotic waveforms for radio communications [2]-[3]. Among the benefits that this approach should carry there is the possibility to design systems which are very robust to multipath impairments as well as to improve the signal quality in a multi-user environment. Most of those features relate with the favorable auto- and cross-correlation properties that

chaotic signals show when used as carriers or spreading sequences.

Direct sequence code division multiple access (DS-CDMA) represents a spread spectrum technique that is used in many wireless communication systems [4], [5]. With DS-CDMA, each active user is assigned a unique sequence or signature, which distinguishes it from other users. The sequences in a spreading code should have low cross-correlation (CC) values to suppress multiple access interference (MAI). The autocorrelation (AC) function of the sequences, on the other hand, should have a narrow peak to avoid inter-symbol interference (ISI) and to enable proper synchronization.

Interference parameter is one form of the optimization criterion as a performance measurement and thus we need to minimize the interference parameter by sequence selection to improve the system performance. Because the interference parameter is related to the Signal-to-Noise Ratio (SNR) and the Bit Error Rate (BER), there are some papers working on minimization of BER or SNR as an optimization criterion by sequence selection using different assumptions, models and so different expressions of BER or SNR [6]-[8].

The performance of a DS-CDMA system degrades with the delay of synchronization. For example, the Global star satellite system is taken as a basic model. Global star is a LEO satellite communication system with CDMA technology, which is already online. Recently immediate synchronization has become very pertinent, due to the fact that it improves the system [9]-[14].

Many people had paid attention to passive network theory [15]-[19]. The passive system is a network theory concept, and has dissipative network characteristics. A system's dynamical characteristic, such as stabilization, etc., can be analyzed by using passive network theory

In this paper, we propose the use of chaotic Lu system to generate binary sequences for spreading codes in a direct sequence spread CDMA system and for minimization of interference parameter in DS-CDMA systems is proposed by using Genetic Algorithms (GA) and the feedback passivity controls is used in order to establish transmitter-receiver synchronization. The concept of semipassivity is defined to find simple conditions which ensure boundedness of the solutions of coupled Lu systems. Numerical result is presented to show the effectiveness of the proposed.

Manuscript received march 6, 2006.

K. Kemih is with the Electromagnetism and telecommunication laboratory, Constantine, 25000, Algeria (corresponding author to provide phone: 213.72006978; fax: 213-34475498; (e-mail: k_kemih@yahoo.fr).

M. Benslama is with the Electromagnetism and telecommunication laboratory, Constantine, 25000, Algeria; (e-mail: malekbenslama@hotmail.com).

II. CHAOTIC LU SYSTEM

We consider Lu system [16]:

$$\begin{cases} x' = a(y - x) \\ y' = -x z + cy \\ z' = x y - bz \end{cases} \quad (1)$$

Lu System has attractor for some typical parameter values: $a=36$, $b=3$, $c=20$. The typical Lu chaotic attractor is showing in figure1. For spreading sequence we use x , figure 2, show the variation of x , with initial condition $[6 -3 1]$, the autocorrelation values of x and cross-correlation values of two code for $N=512$.

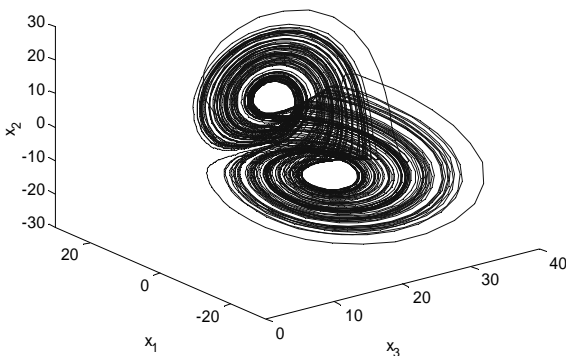

Fig. 1 the typical Lu chaotic attractors

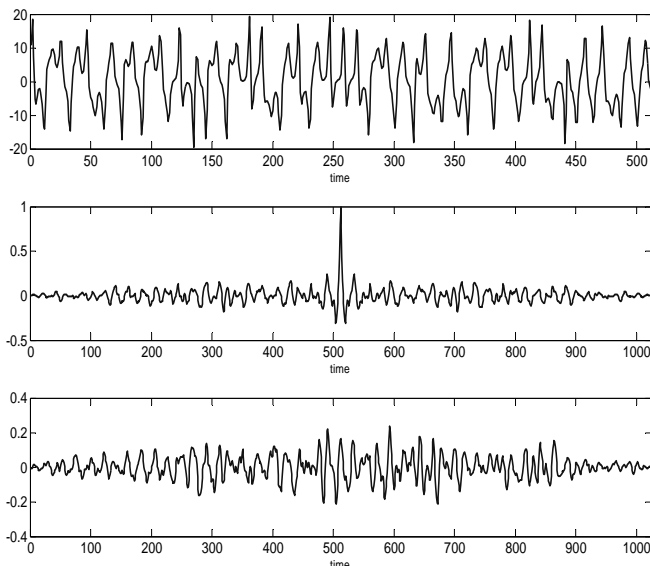

Fig. 2 a- variation of x , with initial condition $[6 -3 1]$; b- autocorrelation values of x ; c- cross-correlation values of two code for $N=512$;

Our approach for generating chaotic binary sequences utilizes correlation criteria to select qualified sequences. It is found that when some special auto- and cross-correlation criteria are applied to the system, the performance of bit-error-rate (BER) of chaotic binary sequences is better than that chaotic real value sequence. In addition, unlike conventional sequences, chaotic spreading codes can be generated for arbitrary length and for any number of sequences.

In general, pseudorandom binary sequences obtained from chaotic (real-valued) sequences are referred to as chaotic binary sequences. A number of methods to obtain chaotic binary sequences from sequences by various chaotic maps have been proposed [9], [11].

The binary chaotic code can be generated by firsts choosing initial condition $[x_0, x_0, z_0]$ which can see as the key in stream cipher or as the user identity in DS-CDMA. Then the map is iterated N times to generate a continuing value code $x = \{x_1, x_2, \dots, x_n\}$. Using a proper quantification function $Q(x)$ we get the code ensembles $a = \{a_1, a_2, \dots, a_n\}$.

The quantization function for a binary code takes the form [11]:

$$Q(x) = \begin{cases} -1 & x < I_{th} \\ 1 & x \geq I_{th} \end{cases} \quad (2)$$

Where I_{th} is the threshold that guaranties the binary code is balanced (number of ones equal number of zeros).

III. OPTIMIZING OF CHAOTIC SPREADING SEQUENCES BY GENETIC ALGORITHM

Consider a direct CDMA system by K active user. The k -th user's data signal $b_k(t)$ is assumed to be on the form of a train of rectangular pulses of unit amplitude and duration T . The spreading code of the k -th user is $a_k(t)$ which consists of periodic sequence of unit amplitude, positive an negative, rectangular pulses of duration T_c the code period is then T/T_c the transmitted signal of the k -th user is :

$$S_k(t) = \sqrt{2P} a_k(t) b_k(t) \cos(\omega_c t + \theta_k)$$

Generally multi-user interfere is represented by cross-correlation function of spreading sequences. According to Mazzini's deduction [22], an expected interference-to-signal ratio per interfering user is given:

$$\sigma^2(I_i) = \frac{1}{6N} \sum_{k \neq i}^K \sum_{l=1-N}^{N-1} [2C_{i,k}(l)C_{i,k}(l) + C_{i,k}(l)C_{i,k}(l+1)] \quad (3)$$

where $C_{i,k}(\tau)$ is the discrete a periodic cross-correlation function

$$C_{i,k}(\tau) = \begin{cases} \sum_{j=0}^{N-l-1} a_j^{(k)} a_{j+1}^{(i)}, & 0 \leq l \leq N-1 \\ \sum_{j=0}^{N+l-1} a_{j-1}^{(k)} a_j^{(i)}, & 1-N \leq l \leq -1 \\ 0, & |l| \geq N \end{cases} \quad (4)$$

The probability of error under the standard Gaussian approximation (SGA) can be given by:

$$P_e = \frac{1}{2} \operatorname{erfc} \left(\sqrt{SNIR} \right) \quad (5)$$

Où *SNIR* is the signal to interference plus noise ration defined by :

$$SNIR = \frac{1}{\frac{K-1}{6N^3} \sigma^2 + \frac{1}{SNR}} \quad (6)$$

The problems $(k-1)\sigma^2$ are integer discrete optimization problems with binary variables. These problems can be solved efficiently by using the genetic algorithm [20], [21] which is a stochastic search method that mimics the metaphor of natural biological evolution. The advantage of the method is its significant computational saving over other discrete optimization methods. It is noted that the presented genetic algorithm can be easily modified to include performance characteristics other than those suggested above.

The idea of the genetic algorithm can be summarized as follows. At the first phase of genetic algorithm, a number of encoded chromosomes called population in the initialization process are generated in that each chromosome (individual) consists of a sequence of binary or real numbers known as genes. In this research, we use an integer as a gene. Once the population is generated and each individual is given a fitness value that is computed by an objective (fitness) function. Then, selection of chromosomes is carried out based on the fitness values of the chromosomes. A type of selection method, Roulette Wheel selection, is used in order that chromosomes having better fitness values can be chosen at a higher chance. The next two operations are crossover and mutation. Crossover allows two chromosomes to exchange part(s) of their genes and mutation changes gene(s) in chromosome(s). After these operations, some modified chromosomes are reproduced. If any modified chromosome has repeating integer(s), it is an illegal solution and chromosome repair will be applied on the chromosome so as to convert it back to a feasible solution. The fitness value of each modified chromosome is evaluated again. Finally, the older chromosomes are replaced by the new and next generation cycle starts. The whole GA process is finished until the maximum generation is reached or the objective is met.

A. Objective function

Our aim is to optimize the interference parameter σ^2 :

$$\sigma^2(I_i) = \frac{1}{6N} \sum_{k \neq i}^K \sum_{l=1-N}^{N-1} [2C_{i,k}(l)C_{i,k}(l) + C_{i,k}(l)C_{i,k}(l+1)]$$

For a code set of *N* chips and *k* active users.

IV. OPTIMIZING OF CHAOTIC SPREADING SEQUENCES BY GENETIC ALGORITHM

Some preliminaries of passivity theory used in this paper will be shortly reviewed for the consistency of the presentation. Passivity is applied to non-linear systems which are modelled by ordinary differential equations with input vector $u(t)$ and output vector $y(t)$: [18]

$$\begin{aligned} \dot{x}(t) &= f(x(t), u(t)) \\ y(t) &= h(x(t)) \end{aligned} \quad (7)$$

The system (1) is dissipative with the supply rate $W(u(t), y(t))$ if it is not able to generate power by itself, that is the energy stored in the system is less than or equal to the supplied power:

$$V(x(t)) \geq 0 \text{ and } V(x(T)) - V(x(0)) \leq \int_0^T W(u(t), y(t)) dt \quad (8)$$

Furthermore, the storage function $V(x(t))$ must satisfy the requirements for a Lyapunov function. If there exist a positive semidefinite Lyapunov function, such that:

$$\int_0^T u^T(\tau) y(\tau) d\tau \geq \int_0^T \left[\frac{\partial V(x(\tau))}{\partial x(\tau)} f(x(\tau), u(\tau)) + e u^T + \delta y^T(\tau) y(\tau) + \rho \phi(x(\tau)) \right] d\tau \quad (9)$$

then the system (7) is passive. A passive system implies that any increase in storage energy is due solely to an external power supply.

Then the equilibrium point of the system:

$$\dot{x}(t) = f(t, x(t), 0) \quad (10)$$

is asymptotically stable in either of the two cases:

- 1- $\rho > 0$
- 2- $e + \delta > 0$ and the system is zero-state observation.

The system (7) can be represented as the normal form:

$$\begin{aligned} \dot{x} &= f(z) + g(z, y)y \\ \dot{y} &= l(z, y) + k(z, y)u \end{aligned} \quad (11)$$

The non linear system (11) may be rendered by a state feedback of the form [15]:

$$u = \alpha(x) + \beta(x)v \quad (12)$$

Next we define a semipassive system. This notion was introduced in [17] and [19], an equivalent notion was called quasipassivity. Roughly speaking, a semipassive system behaves like a passive system for sufficiently large $|x|$. More precisely, assume that there exists a nonnegative function $V : \mathfrak{R}^n \rightarrow \mathfrak{R}_+$ such that for all admissible inputs, for all initial conditions and for all t for which the corresponding solution of (7) exists, we have

$$\dot{V} \leq y^T u - H(x) \quad (13)$$

where the function $H : \mathfrak{R}^n \rightarrow \mathfrak{R}$ is nonnegative outside some ball:

$$\exists \rho > 0, \forall |x| \geq \rho \Rightarrow H(x) \geq \eta(|x|) \quad (14)$$

For some continuous nonnegative function η defined for $|x| \geq \rho$. If the function H is positive outside some ball, i.e., (14) holds for some continuous positive function η , then the system (9) is said to be strictly semipassive.

The concept of semipassivity allows one to find simple conditions which ensure boundedness of the solutions of synchronization systems.

Consider a coupled chaotic Lu system of the form (7) as

$$\begin{cases} \dot{x}_t(t) = f(x_t) \\ y_t(t) = Cx_t \end{cases} \quad \text{and} \quad \begin{cases} \dot{x}_r(t) = f(x_r) + Bu \\ y_r(t) = Cx_r \end{cases} \quad (15)$$

Where: $f(0) = 0$ and B, C constant matrices of appropriate dimension. Define the symmetric 2×2 matrix Γ as:

$$\Gamma = \begin{bmatrix} \gamma_{11} & -\gamma_{12} \\ -\gamma_{21} & \gamma_{11} \end{bmatrix} \quad (16)$$

$\gamma_{i,j} = \gamma_{j,i} \geq 0$ all row sums are zero. The matrix Γ is symmetric and therefore all its eigenvalues are real.

Moreover, applying Gerschgorin's theorem about localization of eigenvalues, one can see that all eigenvalues of Γ are nonnegative, that is, the matrix is positive semidefinite. [15]

We say that the systems (15) are diffusively coupled if the matrix CB is similar to a positive definite matrix and the systems (15) are interconnected by the following feedback:

$$u = -\gamma_{21}(y_r - y_t) \quad (17)$$

where $\gamma_{i,j} = \gamma_{j,i} \geq 0$ are constants.

In this case, we rewrite the systems (15) in a form which can be obtained from (14) via a linear change of coordinates due to the nonsingularity of:

$$\begin{cases} \dot{z} = q(z, y) \\ \dot{y} = a(z, y) + CBu \end{cases} \quad (18)$$

Theorem 1 [15]: Consider the smooth diffusively coupled systems (15) and (18), which, because of the nonsingularity of CB are rewritten as (15) and (18). Assume the following.

Assumption.1. The system

$$\begin{cases} \dot{z} = q(z, y) \\ \dot{y} = a(z, y) + CBu \end{cases}$$

is strictly semipassive with respect to the input u and output y with a radially unbounded storage function V

Assumption.2. There exists a smooth c^2 positive definite function and a positive number α such that

V_0 the following inequality is satisfied :

$$(\nabla V_0(z_1 - z_2))^T (q(z_1, y_1) - q(z_2, y_2)) \leq -\alpha |z_1 - z_2|^2 \quad (19)$$

Theorem 2 [8]: Assume that there exists a positive definite matrix $P = P^T$ such that all eigenvalues of the symmetric matrix

$$\frac{1}{2} \left[P \left(\frac{\partial q}{\partial z}(z, \xi) \right) + P \left(\frac{\partial q}{\partial z}(z, \xi) \right)^T P \right]$$

are negative and separated from zero for all $z \in \mathfrak{R}$ and $\xi \in D$. Then the system $\dot{z} = q(z, 0)$ is noncritically convergent in the class ID .

We consider Lu system:

$$\begin{cases} x'_t = a(y_t - x_t) \\ y'_t = -x_t z_t + cy_t \\ z'_t = x_t y_t - bz_t \end{cases} \quad (20)$$

We assume Eq. (20) to be the transmitter and we select its output as:

$$y = y_t \quad (21)$$

Then the receiver equations are

$$\begin{cases} x_r' = a(y_r - x_r) \\ y_r' = -x_r z_r + c y_r + u \\ z_r' = x_r y_r - b z_r \end{cases}$$

To force the two systems to synchronize, a connection is needed between the two systems. If the purpose of the control is to force $y_r \rightarrow y_i$ as $t \rightarrow \infty$, we can add control terms u into the receiver system in the form of

$$u = -\gamma_{21}(y_r - y_i) \quad (22)$$

First, we check that the receiver system is strictly semipassive with respect to the input u and output y_r .

To this end, consider the smooth function:

$$V(x_r, y_r, z_r) = \frac{1}{2}(x_r^2 + y_r^2 + (z_r - a)^2) \quad (23)$$

Its time derivative with respect to the uncontrolled system satisfies:

$$\dot{V} = -ax_r^2 - y_r^2 - b\left(z_r - \frac{a}{2}\right)^2 + b\frac{(a)^2}{4} \quad (24)$$

It is seen that $\dot{V} = 0$ determines an ellipsoid outside of which the derivative of V is negative. If K satisfies

$$K^2 = \frac{1}{4} + \frac{b}{4} \max\left\{\frac{1}{a}, 1\right\} \quad (25)$$

Then this ellipsoid lies inside the ball

$$\Xi = \{x, y, z : x_r^2 + y_r^2 + (z_r - a)^2 \leq K^2 a^2\} \quad (26)$$

which means that all solutions of the uncontrolled system approach within some finite time the set defined by (23). Calculating the time derivative of along solutions of the system (18) yields

$$\dot{V}(x_r, y_r, z_r, u) = \dot{V}(x_r, y_r, z_r, 0) + y_r u \quad (27)$$

Therefore, the function V is a storage function which proves strict semipassivity of the system (18) from the input to the output.

Secondly, we find the zero dynamics by imposing the external constraints $y_r = y_i$,

$$\begin{cases} x_r' = a(y_i - x_r) \\ z_r' = x_r y_i - b z_r \end{cases} \quad \text{and} \quad \begin{cases} x_r' = a(y_i - x_r) \\ z_r' = x_r y_i - b z_r \end{cases} \quad (28)$$

Now we show that the receiver system is noncritically convergent for any bounded $y_r(t)$. Indeed, the symmetrized Jacobi matrix for this system has two eigenvalues $-a$ and $-b$ and, therefore, according to Theorem 2, there exists a quadratic function which satisfies Assumption A2 of Theorem 1.

Thus, all the conditions of Theorem 1 are satisfied and coupled Lu systems has an asymptotically stable compact subset of the set $\{x_i = x_r, y_i = y_r, z_i = z_r\}$.

V. NUMERICAL RESULTS

In this section, results of minimization of interference parameter are given as below. The genetic algorithm is used in the selection of chaotic code over random selection of initial conditions for different code lengths and different number of users. In order to show the improvement of these proposed approach, we compare the results with the results presented in [11] with classical spreading code as m-sequences, Gold codes and Kassami code and logistic map code with the same code length and the same number of users. Parameter of genetic algorithm are given as below in tableau 1

TABLE I
GA PARAMETERS

Parameter	Value
Population size, N_p	100
Generation, G_{\max}	800
Crossover probability, P_c	0.6
Mutation probability P_m	0.7

TABLE II
INTERFERENCE PARAMETER OPTIMIZED RESULTANTS OF DIFFERENT METHODS

N	k	Classical codes				Logistic map	Proposed approach	
		Code family	AO/LS E	LES/AO	CO/MSQCC	MSQCC-CO	AG	Lu system with GA
15	2	M	430	430	410	358	94	69
15	4	SK	1224	1224	1184	1186	440	392
15	15	LK	6608	6608	6663	6646	4641	4324
31	6	M	9963	9598	9148	9434	6248	5356
31	33	G	60268	60231	61566	62570	51007	49785
63	6	M	40398	40089	39086	41769	28915	26812
63	65	G	503850	504070	513710	521920	434140	402367
127	18	M	556540	557080	552900	567390	465440	448561

M: m-sequence; SK: Small Kassami, LK: Large kassami, G: Gold code
 AO/LES, LES/AO, CO/MSQCC, MSQCC/CO: classical method for code optimization

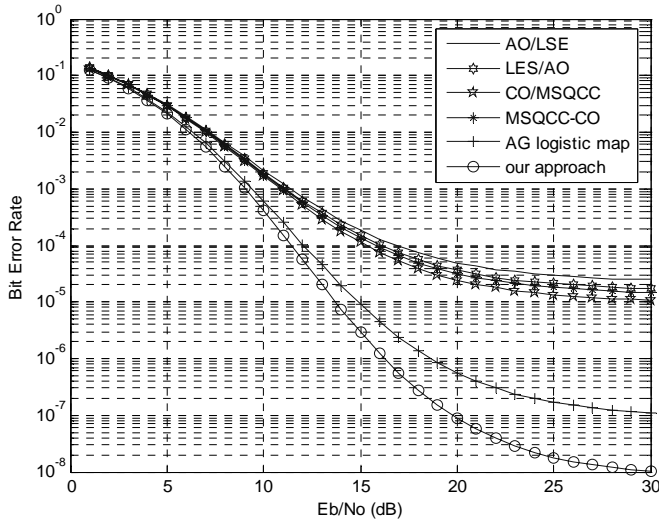

Fig. 1 variation BER via Eb/No for N=31 and K=6

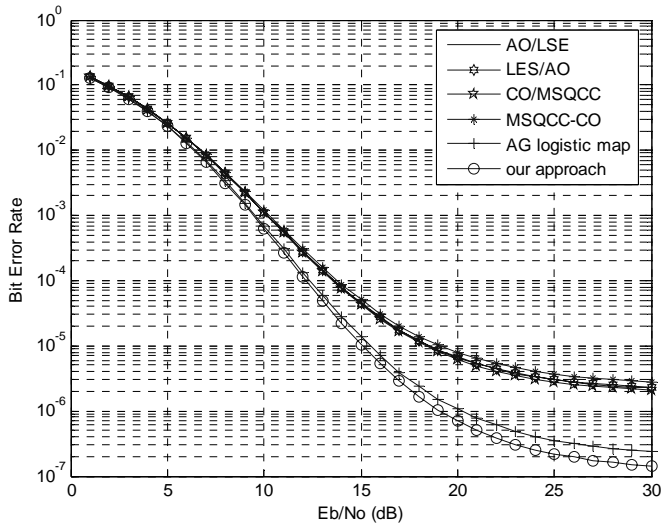

Fig. 2 variation BER via Eb/No for N=127 and K=18

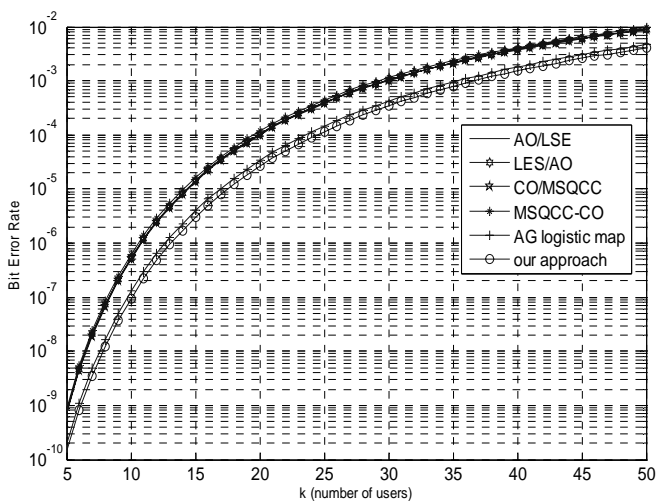

Fig. 3 variation BER via K for SNR=15 and N=127

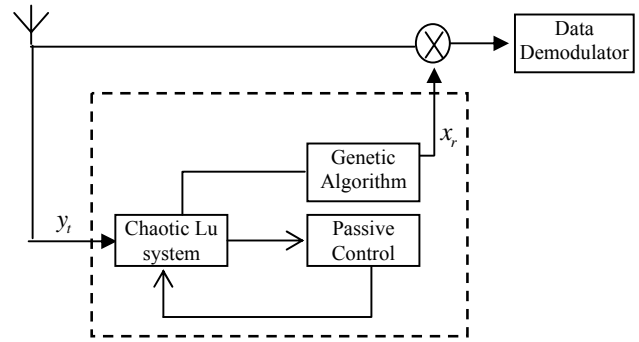

Fig. 4 proposed schema

Fig. 1 and Fig. 2 show the variation of BER via Eb/No with different values of N and K. Fig.3 Variation BER via K for SNR=15 and N=127. From this figure, we can see the improvement of optimized chaotic lu system with over classical codes optimized with classical methods for different code lengths and different number of users.

In Fig.4 we show the proposed schema for synchronization and spread sequence in CDMA system

The goal is to force the two systems to synchronize under control, while they have different initial conditions. The transmitter system starts from [6 -6 5] and the receiver system from [-3 -2 -4]. We select $\gamma_{12} = 4$ and use the controller as in (19): $u = -4(y_r - y_t)$.

In figure 5 and figure 6, we note that the system is quickly and perfectly synchronized, also the bigger γ_{12} give the best performance.

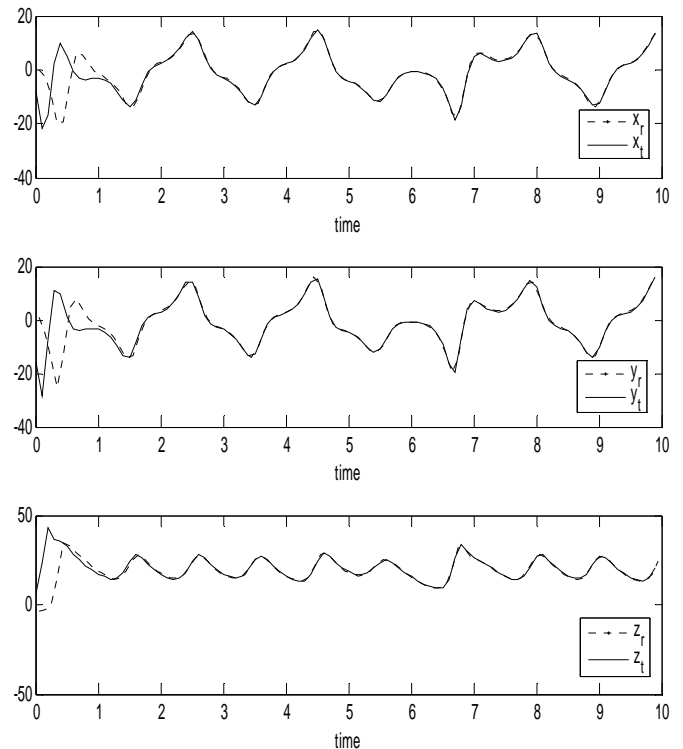

Fig. 4 Synchronization of two Lu system with proposed method

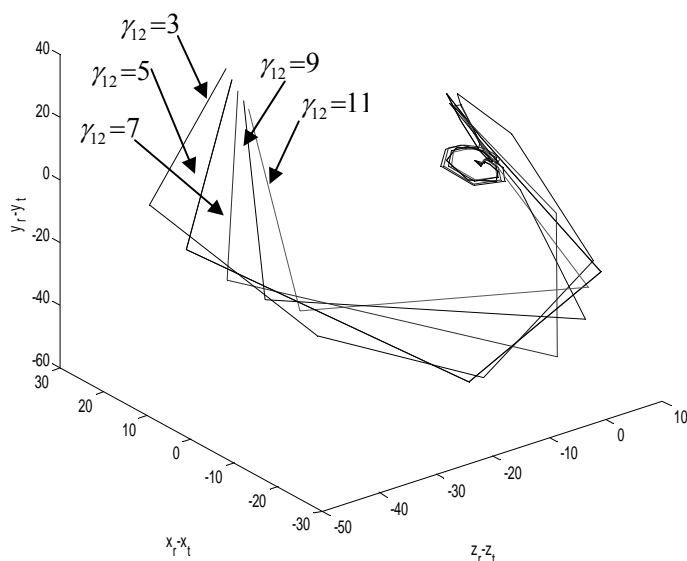

Fig. 5 Phase-space trajectory

VI. CONCLUSION

In direct sequence code division multiple access (DS-CDMA) applications, system performance depends on the autocorrelation and cross-correlation properties of the used spreading sequences and the transmitter receiver synchronization. In this paper we have proposed the uses of chaotic Lu system to generate binary sequences for spreading codes in a direct sequence spread CDMA system. To minimize multiple access interference (MAI) we have proposed the use of genetic algorithm for optimum selection of chaotic spreading sequences. Also the problem of controlled synchronization of Lu system in CDMA satellite system was presented. passivity nonlinear control techniques are presented and semipassivity technique was defined to find simple conditions which ensure boundedness of the solutions of coupled systems. Experimental results showed that MAI could be greatly reduced and these approach are more adapted for DS-CDMA system than M-sequences, Gold codes, Kassami code and logistic map and the system is quickly and perfectly synchronized with the proposed method

REFERENCES

- [1] Pelton (J. N), Oslund (R. J), "Communications satellites :global change agents", Lawrence Erlbaum associates, publishers mahwah, New Jersey London, 2004
- [2] Wang (W.), Blostein (S.), "Video image transmission over mobile satellite channels, Signal Processing Image communication", 2001, pp. 531-540.
- [3] M. P. Kennedy, G. Kolumbán, G. Kis, Z. Jákó, "Recent advances in communicating with chaos", Proc. IEEE-ISCAS '98, Monterey, CA, , vol. IV, 1998, pp. 461-464
- [4] Vojcic (B. R.), Milstein(L. B.), Pickholtz (R. L.), "Downlink DS CDMA Performance Over a Mobile Satellite Channel", IEE Trans. Veh. Technol., vol. 45, no. 3, pp 551-559, 1996
- [5] De Gaudenzi (R.) and Giannetti (F.), "DS-CDMA satellite diversity reception for personal satellite communication: Satellite-to-mobile link

- performance analysis", IEEE Trans. Veh. Technol, vol. 47, pp. 658-672, 1998
- [6] H. H. Dam, H. Zepernick, and H. L'uders, "On the Design of Complex-valued Spreading Sequences Using a Genetic Algorithm" , IEEE Proc ISSSTA 2004, Australia, 2004, pp. 704-707.
- [7] P. J. E. Jeszensky, J. R. F. Junior, "Sequences selection for quasisynchronous CDMA systems", Proceedings of ZEEE 5thInternational Symposium on Spread Spectrum Techniques and Applications, vol.3, no.30, 1998, pp.706-708.
- [8] A Mizaee and H. Aghaenia, "Design of new class of spreading sequence using chaotic dynamical systems for asynchronous DS-CDMA application", Proc of ISCC04, 2004, pp 720-724.
- [9] G. Kolumbán, M. P. Kennedy, L. O. Chua, "The role of synchronization in digital communication using chaos – Part II: Modulation and chaotic synchronization", IEEE Trans. Circuits and Systems I, vol. 45, pp. 1129-1139, November 1998
- [10] T. Liao and N. Huang, "An observer-based approach for chaotic synchronization with applications to secure communications," IEEE Trans. Circuits Syst.—I: Fundamental Theory Applicat., vol. 46, pp. 1144–1150, Sept. 1999
- [11] L. M. Pecora and T. L. Carroll, "Synchronization in chaotic systems", Phys. Rev. Lett., vol.64, no. 8, pp. 821-824, 1990.
- [12] T. L. Carroll and L. M. Pecora, "Synchronization in chaotic circuits", IEEE Trans. On Circuits Syst., vol. 38, no. 4, pp. 453-456, 1991.
- [13] L. Kocarev and U. Parlitz, "General approach for chaotic synchronization with application to communication", Phys. Rev. Lett., vol. 74, pp. 5028-5031, 1995
- [14] Hong (Y.), Qin (H.), Chen (G.), " adaptive synchronization of chaotic systems via state or output feedback control", International Journal of Bifurcation and Chaos, vol. 11, no. 4, pp. 1149-1158, 2001
- [15] Pogromsky (A.), Nijmeijer (H.), "Cooperative Oscillatory Behavior of Mutually Coupled Dynamical Systems", IEEE transactions on circuit and systems: fundamental theory and applications, vol. 48, no. 2, pp 1149-1158, 2001
- [16] K. Kemih, S. Filali, M. Benslama and M. Kimouche, "Passivity based control of Lu system", to appear in IJICIC journal, vol.2, no. 2, 2006
- [17] C. I. Byrnes, A. Isidori and J. C. Willems, "Passivity, feedback equivalence and the global stabilization of minimum phase nonlinear systems", IEEE Trans. Automat. Contr., 36(1), pp. 1228–1240, 1991.
- [18] Yu (W), "Passive Equivalence of Chaos in Lorenz System", IEEE Transaction on circuits and systems-1:fundamental theory and applications, vol. 46,no. 7, pp.876-878, 1999
- [19] Polushin (I. G.), Hill (D. J.), and. Fradkov (A. L), "Strict quasipassivity and ultimate boundedness for nonlinear control systems", Proc. 4th IFAC Symp. Nonlinear Control Systems, NOLCOS'98, 1998, pp. 527–532.
- [20] H. Chou, G. Premkumar, and C. Chu, "Genetic algorithm for communications network design- an empirical study of the factors that influence performance," IEEE Trans.Evolutionary Computation, vol. 5, pp. 236–249, June 2001.
- [21] Z. Altman, R. Mitra, and A. Boag, "New designs of ultra wide-band communication antennas using a genetic algorithm," IEEE Trans. AntennasPropagat., vol. 45, pp. 1494–1501, Oct. 1997
- [22] Mazzini G., Rovatti R. and Setti G. "Sequences synchronization chaos-based DS-CDMA systems". IEEE international symposium on circuit and antenna (ISCAS'98). Monterey, California, USA. 1998, part 4 of 6: pages485-488.
- [23] S.E. El-Khamy, M.M. Gad, S.E. Shaaban, "Optimization of chaotic spreading codes for asynchronous DS-CDMA applications using genetic algorithms", Radio Science Conference, 2005. NRSC 2005. Proceedings of the Twenty-Second National, March 15-17, 2005, C3, pp1-11

Karim Kemih received his BScEE from Mentoury University and MScEE degrees from Jijel University Algeria. He is currently PhD student at Electromagnetism and telecommunication laboratory. Twenty journal and conference proceeding papers have been derived from his work. The research interests Kemih are: control and synchronization of chaotic system, wireless Communications; research on the physical layer of communications systems: multi-user communication, satellite and terrestrial

wireless systems, CDMA, OFDM, statistical signal processing, antenna diversity

Malek Benslama (M'89) received the BS, MS, and PhD degrees from National Institute Polytechnic INP Toulouse France in 1979, 1982, and 1992. In 1992, he was a Faculty Member with electronics Department, mentouri university, Algeria. Benslama is the Founder of the Electromagnetism and Telecommunication Laboratory. His research interests are in applied electromagnetics, with current emphasis on the aberrations of offset reflector antennas, wireless Communications; research on the physical layer of communications systems: multi-user communication, satellite and terrestrial wireless systems, CDMA antenna diversity
Pr. Benslama is a Member **IEEE**, and **SIAM**.