

Design of Non-Blocking and Rearrangeable Modified Banyan Network with Electro-Optic MZI Switching Elements

Ghanshyam Singh, Tirtha Pratim Bhattacharjee, R. P. Yadav, and V. Janyani

Abstract—Banyan networks are really attractive for serving as the optical switching architectures due to their unique properties of small depth and absolute signal loss uniformity. The fact has been established that the limitations of blocking nature and the non-availability of proper connections due to non-rearrangeable property can be easily ruled out using electro-optic MZI switches as basic switching elements. Combination of the horizontal expansion and vertical stacking of optical banyan networks is an appropriate scheme for constructing non-blocking banyan-based optical switching networks. The interconnected banyan switching fabrics (IBSF) have been considered and analyzed to best serve the purpose of optical switching with electro-optic MZI basic elements. The cross/bar state interchange for the switches has been facilitated by appropriate voltage switching or the by the switching of operating wavelength. The paper is dedicated to the modification of the basic switching element being used as well as the architecture of the switching network.

Keywords—MZI switch, Banyan network, Reconfigurable switches.

I. INTRODUCTION

THE Internet is experiencing an exponential growth in bandwidth demand from large numbers of users in multimedia applications and scientific computing, as well as in academic communities and the military. As a result of Wavelength Division Multiplexing (WDM) technology, the number of wavelengths per fiber has been increased to hundreds or more with each wavelength operating at rates of 10Gbps or higher [1]. Thus, the use of all-optical mesh networks based on WDM technology holds a great promise to meet the Internet's ever increasing bandwidth demands, because the mesh-in-nature Internet backbones are considered more capacity-efficient and survivable.

Ghanshyam Singh is with Department of Electronics & Communication Engineering [ECE], Malaviya National Institute of Technology (MNIT) Jaipur-302017, India (phone-91-141-2713431, mobile- 91-9413965611, e-mail- gschoudhary75@gmail.com).

Tirtha Pratim Bhattacharjee is with Department of ECE, MNIT, Jaipur-30217, India (e-mail: convey2tpb@hotmail.com).

R. P. Yadav is with Department of ECE, MNIT, Jaipur-30217, India (e-mail- rp_yadav@yahoo.com).

Vijay Janyani is with Department of ECE, MNIT, Jaipur-30217, India (e-mail- vijayjanyani@gmail.com).

It is expected that the traffic carried on tens of fibres at each node in a WDM mesh network will soon approach several terabits per second. Switching such a huge amount of traffic electronically becomes very challenging, due to both the high cost of optical-electronic-optical conversion and the high costs related to heat dissipation and space consumption.

Although terabit capacity IP routers based on electronics are now starting to appear, there is still a serious mismatch between the transmission capacities of WDM (especially DWDM) fibres and the switching capability of electronic routers. Therefore, the adoption of all-optical switching networks in WDM networks has been an active research area for nearly two decades. Optical switching networks not only have the potential to steer network traffic at the speed of hundreds of terabits per second or higher [2], but they also can be more cost-effective than their electronic counterparts, even for applications requiring lower throughput. It is envisioned that in future WDM mesh networks, optical switching networks will play a key role in the transportation plane because they will be embedded with the intelligence of routing and signalling that enable them to handle complex mesh topologies and large numbers of inputs with different wavelengths, particularly at switching hubs that deal with a large volume of optical flows.

II. MZI SWITCH (SINGLE UNIT)

The Mach-Zehnder Interferometer switch (used with unequal interferometric arm lengths in the switch network) cycles between the cross state, where most of the light appears in the waveguide on the same side as the input, and the bar state, where most the light moves to the waveguide on the other side. In the proposed communication system (Fig. 1) where wavelength 1.3 μm is being used for transmission and 1.5 μm , for reception on the same fibre, the circuit remains in a bar state for 1.3 but in a cross at 1.5 so that most of the received light can be sent to the receiver, and not to the transmitter, without compromising the insertion loss between the transmitter and the fibre [1]. The ideal behaviour of the couplers in the switch (the 3dB point) could be changed to 1.3 or 1.5 to minimize the insertion loss of the transmitter or receiver, at the expense of the other, which is achieved by obtaining waveguide narrowing distance of 5.4683 μm in the couplers.

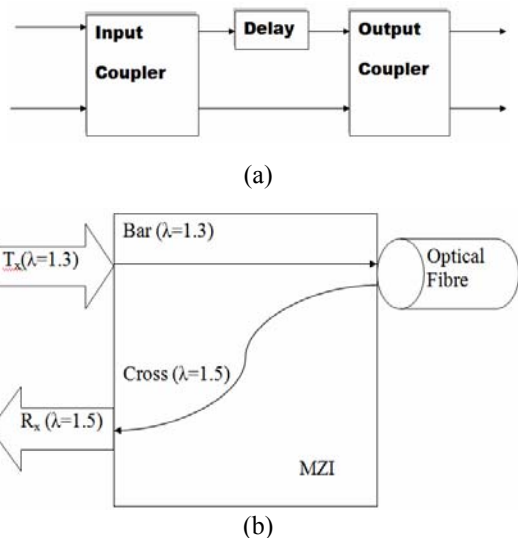

Fig. 1 Layout of (a) structure and (b) functioning of MZI with unequal interferometric arms

The phase difference between the two arms will be:

$$\Delta(\lambda) = 2\pi n \frac{L}{\lambda} \quad (1)$$

where L is the difference in the path length of the two arms, n the modal index of the waveguide (estimated as 1.485). As the path difference is increased, the MZI will cycle between cross and bar states, the crosses occurring at multiples of 2π , and the bars interlacing. To obtain a circuit of minimum size, the minimum possible phase change between the design wavelengths, 1.5 and 1.3, is used.

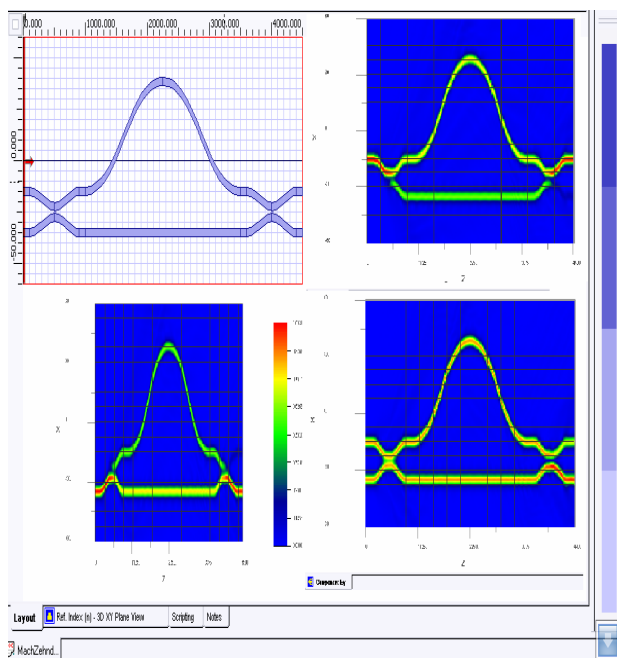

Fig. 2 The waveguide of the proposed MZI switch (in bar state) with simulations for Optical Field Propagation for inputs in different or both ports of the switch (courtesy optiBPM module of Optiwave software)

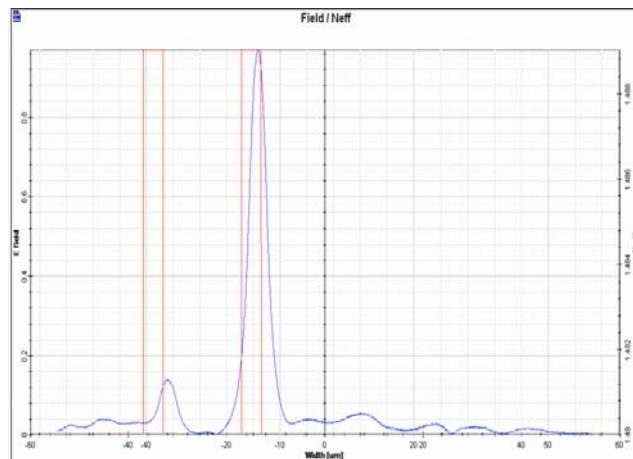

Fig. 3 The graph plotted with variations in relative field strength and the effective refractive index of the waveguide with the width of the wafer used in the switch architecture (courtesy optiBPM module of Optiwave software)

The transmission wavelength, 1.3, should be placed at a cross and the reception wavelength, 1.5, at an adjacent bar. If L is chosen such that $\Delta(1.3) = 7\pi$ (bar state) then the state at the Rx wavelength, 1.5, is very close to a cross: $L = 3.064$, and $\Delta(1.5) = 6.067\pi$ (nearly cross). The simulations for the bar state of the switch is shown in Fig. 2.

The graph (Fig. 3) shows the introduction of the S-bends in the interferometer arms for the switch compaction in length that does not lead to major alterations in the optical field propagation through the waveguide and the concurrent losses are also bearable up to some extent.

III. BANYAN ARCHITECTURE OF MZI SWITCHES

A typical N X N Banyan Network consists of $\log_2 N$ stages, each containing $N/2$ 2 X 2 switches and the link connections between adjacent stages are implemented by recursively applying the butterfly interconnection pattern (Fig. 4). In a banyan network there is a unique path between an input port and an output port, and the number of switching elements in each path is fixed and equal to $\log_2 N$. All these characteristics well claim the banyan networks perfect for constructing optical switching networks based on directional couplers / switches because losses and attenuations are proportional to the number of couplers / switches, the optical signal crosses.

The uniqueness of the paths between the input and output ports restrict rearrangement of existing connections to make the circuit non-blocking thereby not supporting two connections using a common link concurrently. Furthermore, in order to make the architecture crosstalk free, no two paths should be allowed to use the same switching element. This constraint has a very significant impact on the overall blocking probability of the network (i.e. the probability that a new connection will be successfully realized).

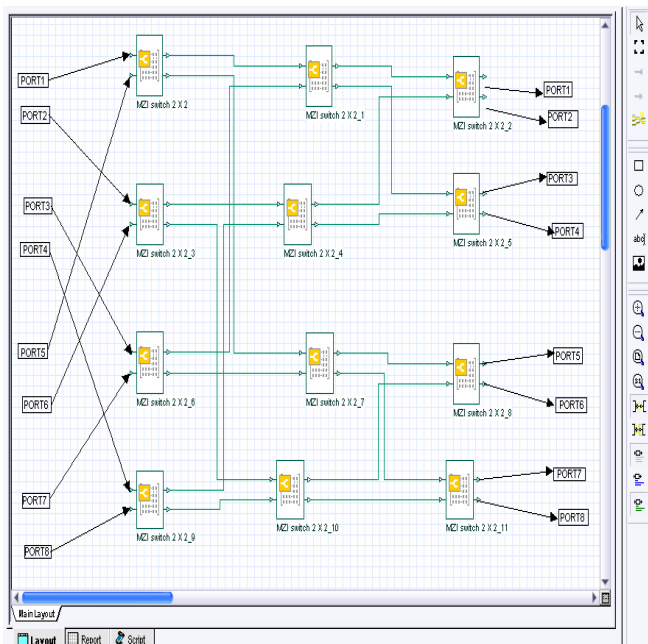

Fig. 4 The typical Banyan Network (8 X 8) of MZI switches clearly showing the input ports {left set} and output ports {right set} of the network (courtesy OptiSystem module of optiwave software)

Although the banyan network is a blocking network, such networks can be connected to produce a network with greater connection capabilities. In addition to that, the banyan network also possesses relatively very low cross-talk characteristics due to the small number of optical switch element ranks.

So as to minimise the problems with the banyan tree, the approach can be towards modification of the individual switching elements and vertical as well as horizontal expansion of banyan tree as per our requirements also keeping in mind the complexity of the network due to extra layers incorporated.

IV. ELECTRO-OPTIC MZI SWITCHES

So as to have the modified banyan network rearrangeable in any case of blocking we can incorporate electro-optic MZI switches. In electro-optic switches, the switching function is achieved by changes in physical properties of materials caused by the application of an electrical voltage. The observed phenomenon typically include changes in the index of refraction of materials and are collectively referred to as electro-optic effects [3].

The material used is Lithium-Niobate [LiNbO₃] which has a large electro-optic coefficient allowing very fast transition times with moderate switching voltages. An electrical voltage changes the refractive index of the substrate which in turn manipulates the light through the appropriate waveguide path to the desired port in the proposed switch structure (Fig. 5).

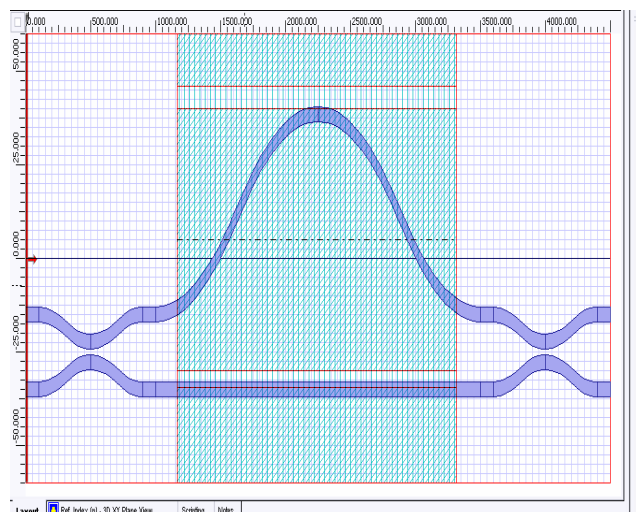

Fig. 5 The waveguide of the proposed electro-optic MZI switch clearly showing the electrode regions (courtesy optiBPM module of Optiwave software)

So applying the electric voltage we can change the switching characteristic of the switches. If the voltage is kept at zero the default switch will remain in the bar state. When the appropriate switching voltage (assumed to be 6.75V approx), the switch goes on into the cross state.

TABLE I
 SPECIFICATIONS FOR ELECTRODE REGION AND SWITCHING VOLTAGES

Electrode 1		Electrode 2		Electrode 3		Gap 1-2	Gap 2-3	
W	V	W	V	W	V	W	W	
120	0.0	70	0.0	120	0.0	6.0	4.5	
120	0.0	70	6.75	120	1.5	6.0	4.5	
Electrode 2 center position							5.5	

Stripe thickness before diffusion		0.05 micrometer	
Dopant constant		5.67 e +022 per cm ³	
Dh	4.0 μ mts	Dv	3.5 μ mts

The phenomenon of changing characteristics of the switch can be of high importance in the modification of banyan network [4]. The modified banyan network can be made rearrangeable so as to accommodate switching fluctuations as per the demand of the network. The switching voltage of all the individual electro-optic MZI single units can be well controlled by control signals as per the instantaneous connectivity of the input and output ports in the network. The changing of the electrical switching voltages can be easily detected in the network and the connectivity gets rearranged

within a few milliseconds (terabits/sec rate of external communication for switching).

V. HORIZONTAL AND VERTICAL EXPANSION

However, with a banyan topology, only a unique path can be found from each network input to each network output, which degrades the network to a blocking one. A general approach to building banyan-based non-blocking optical switching networks is to jointly perform horizontal expansion and vertical stacking [5] in which a regular banyan network is first horizontally expanded by adding some extra stages to the back of the network, and then multiple copies of the horizontally expanded banyan network are vertically stacked.

When two optical signals traverse through a single switch at the same time, a small portion of optical power in one waveguide will be coupled into the other unintended waveguide. This undesirable coupling is called the first-order crosstalk. This first-order crosstalk will propagate downstream stage by stage, leading to a higher order crosstalk in each downstream stage with a decreasing magnitude. Due to the stringent bit-error rate requirement of fiber optics, crosstalk elimination has become an important issue for improving the signal-to-noise ratio of the optical flow transmission [6]. A cost-effective solution to the crosstalk problem is to guarantee that only one signal passes through a single switch at a time, thus eliminating the first-order crosstalk.

So, opting for the simultaneous horizontal as well as vertical expansion of the modified banyan network must be towards the perfection that no common individual switch is expected to be part of the link for two different sets of input and output ports. But the expansion comes with a high hardware cost or a large network depth to guarantee the non-blocking property. Blocking behavior analysis of a network is an effective approach to the study of network performance and to finding a desirable trade-off between hardware costs and blocking probability.

The horizontal expansion of two extra stages (Fig. 6) leads to the path of attaining non-blocking feature for the modified banyan network. The vertical extension for the network can be determined with the simulation of the network to get the minimum number of vertical planes needed to attain the complete non-blocking status for the modified network.

The upper and lower bound set for the blocking probability for such a modified network with simultaneous horizontal and vertical expansion is feasible [5] and the minimum number of vertical planes stacked together is also set low. So the realization of the modified architecture of the network gets facilitated.

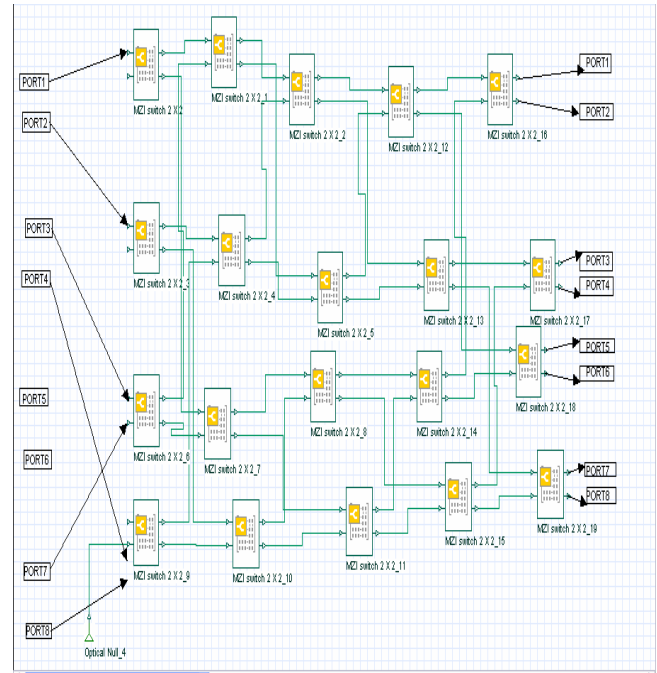

Fig. 6 The modified Banyan Network (8 X 8) of MZI switches clearly showing the input ports {left set} and output ports {right set} of the network with horizontal expansion of 2 extra stages (courtesy OptiSystem module of optiwave software)

VI. INTERCONNECTED BANYAN SWITCH FABRIC

Multistage Interconnection Networks (MINS) have received considerable attention as an interconnection mechanism between processors and memory modules [7] due to their self-routing capability and favourable cost-performance ratio. But since there is only one path between a source and a destination, and intermediate nodes of paths are shared in MINS, they have a high blocking probability and low throughput, and most of them are not fault tolerant. IBSF is a structure under the MINS category which is symmetrical to Piled Banyan Network structurally but it does not have latency unlike others and it also provides best pass-through ratio.

A switching element (SE) of the IBSF (Fig. 7) is a 4x4 switch, except SEs in stage 0 which are 2x4 switches. The IBSF consists of multiple banyan networks, each of which is called a layer [8]. The structure of the BSF is three dimensional. As each source is connected to stage 0 of each layer, packets are distributed to the different layers in the beginning. Two outputs of each SE are connected to the next stage in the same layer and the other two outputs are connected to the next stage of the lower layer. So two inputs of an SE are from the same layer and two inputs are from the upper layer. When there is a conflict, one packet is routed to the same layer and another one is routed to the lower layer. The bottom layer is connected to the top layer. So every layer is connected to another layer.

There would be much waste if a packet arrived successfully at the last stage and could not get to its destination due to a

conflict at the last stage. So, two outputs from the last stage are connected to the same destination. In two-layer IBSF, each destination can get 4 packets (two from layer 1 and two from layer 2) at the same time.

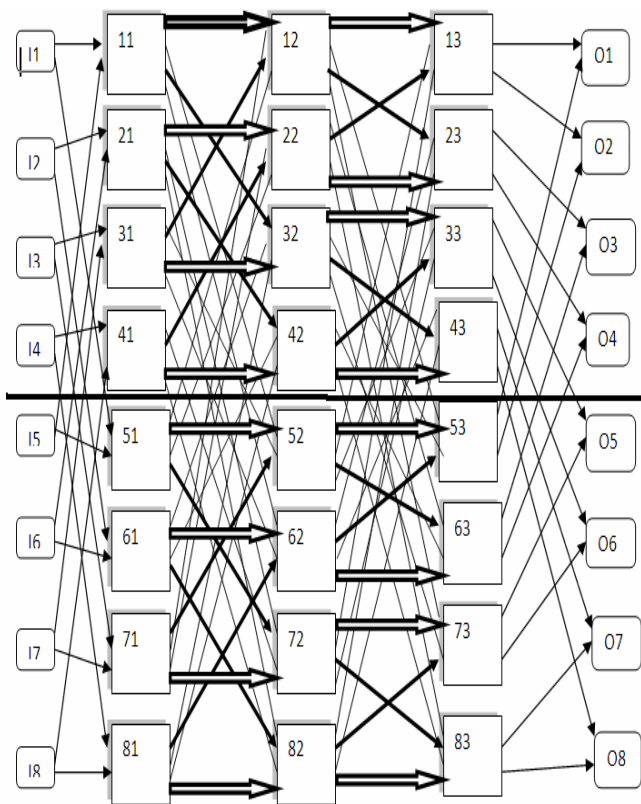

Fig. 7 Structure of two layer 8X8 IBSF

At each SE there are two paths leading to the same destination. If the number of layers is L and the size of the network is N, then the number of paths which take at least one different SE between a source and a destination is $L \cdot (N/2)$. As an illustration, if input port I1 is taken as source and the signal to be destined to the output port of O1, then two distinct routes can easily be sorted out for the packet transfer.

I1 >> 11 >> 52 >> 13 >> O1
 I1 >> 51 >> 12 >> 53 >> O1

So the paths can be rearranged by changing the states of the electro-optic MZI switches through control signals. The control signals can be mastered as per the network connection requirements and the intelligent control system for the same is not discussed in the paper.

As each output of an SE is connected to the next stage of the same layer or of the lower layer, there is no delayed latency at all. The drawback of the IBSF lies in the fact that if more than two packets conflict in an SE only two packets will survive and the others are discarded. But this phenomenon can be reduced or eliminated as packets are distributed to different layers in stage 0 if more layers are added. The previous works in the analysis of throughput confirm that even two-layer IBSF achieves up to 95% of pass-through ratio [8].

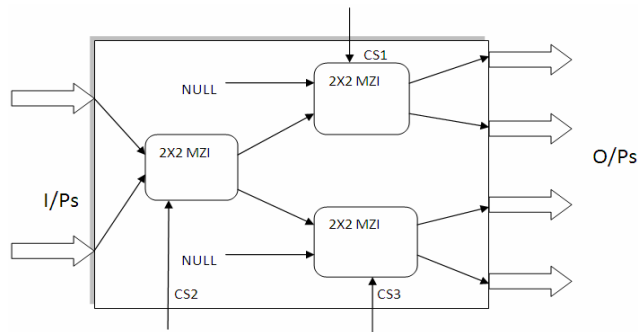

Fig. 8 Microstructure of Input Stage Switching Block

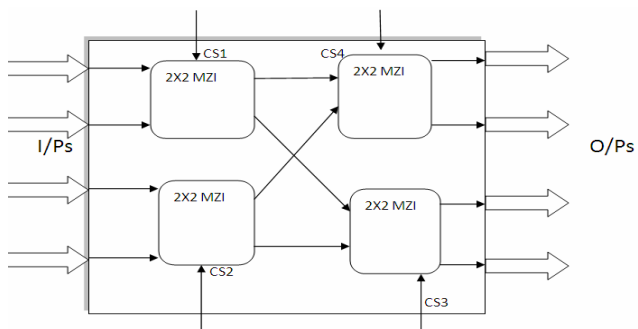

Fig. 9 Microstructure of Middle Stages Switching Block

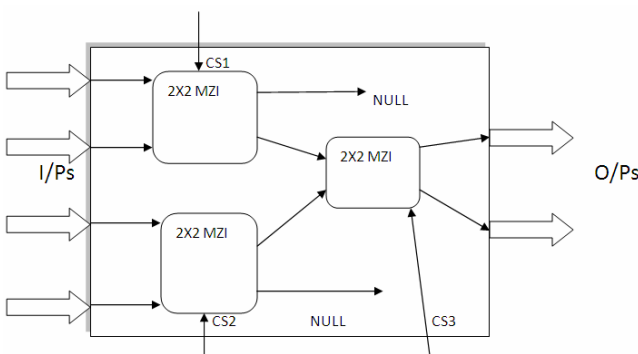

Fig. 10 Microstructure of Output Stage Switching Block

The stage coverage of the paths connected is simulated for the performance analysis. The signal traverses two MZI switches in each switching block irrespective of the microstructures of the input stage (Fig. 8), middle stages (Fig. 9) and output stage (Fig. 10) of the network. So in case of a network with three stages and two layer foundation, the signal gets attenuated in six in-path continuous switches before reaching the destination port.

The accumulation of losses can be avoided by the application of SOAs in layer interchanges with compact size and proper charge injection. The feasibility of the modified switch structure can be explained through experiments [9].

Some points regarding the IBSF features are as follows:

- It resolves conflicts at the bottom layer as it is connected to the top layer.
- It resolves conflicts at the last stage as it has two outputs to the same destination at an SE.

- It avoids the discarding of packets by distributing packets that have arrived to all layers.

With 3 layers IBSF, we can get a 93.8% pass-through ratio for a 230x230 network [8]. The throughput of the IBSF does not reduce very much, even though the network size grows very big. This suggests that the IBSF can surely be used for very large sized MIN.

The IBSF is very much compatible for the practical use with the incorporation of the proposed MZI switch elements. The rearrangeability of the paths in the proposed network is proven to be beneficial in improving the pass-through ratio. The crossovers in the network are generally sources of noise introduction but the proper fabrication of on-chip structures with optical insulator padding can come over with extraordinary performance. The crossovers can also be avoided by rearranging the paths in a way that maximum network linkages are formed in the parallel direction with inter-layer linkages.

VII. CONCLUSION

The proposed switch element and the modified banyan network can be concluded to be an appropriate model in the path of attaining low cross-talk as well as proper non-blocking status for the network. The use of electro-optic MZI switches is bestowed with the advancement of the user interface facilitation of the network through proper control signals dedicated for the connectivity and switching.

The proposed IBSF proved to be efficient with high pass-through ratio and efficiency with the proposed SEs. The scope of further work lies in the flexibility enhancement of the structure and loss minimisation with proper channelling of the signals. The interchanging layer delays are also posing threat to the feasibility of the structure and claim further research.

ACKNOWLEDGMENT

The paper is dedicated to the institutional excellence in research works. We want to heartily thank all the colleagues and friends for their extended support and TEQIP, MNIT for the procurement of OptiWave software.

REFERENCES

- [1] Georgios I. Papadimitriou, Senior Member, IEEE, Chrisoula Papazoglou, and Andreas S. Pomportsis, Member, IEEE. "Optical Switching: Switch Fabrics, Techniques and Architectures." Vol. 21, no. 2, February 2003.
- [2] Yasumasa Suzuki, Shigehisa Arai, Satoshi Baba, and Masaki Kohtoku "Enhancement of Electric Field-Induced Refractive-Index Variation in a (GaInAsP) (InAs) / InP Asymmetric Multiple- Quantum-Film (MQF)." IEEE Transactions Photonics Technology Letters, Vol. 3, No. 12, December, 1991 structure.
- [3] 761 Wol-Yon Hwang, Min-Cheol Oh, Member, IEEE, Hyang-Mok Lee, Heuk Park, and Jang-Joo Kim "Polymeric 2x2 Electrooptic Switch Consisting of Asymmetric Y Junctions and Mach-Zehnder interferometer." IEEE Photonics Technology letters, Vol. 9, No. 6, June 1997.
- [4] Fenghai Liu, Xueyan Zheng, Rune J.S. Pedersen* and Palle Jeppesen. "Fully reconfigurable 2x2 optical cross-connect using tunable wavelength switching modules." Research Center COM, Technical

University of Denmark, Building 349, Lyngby, DK-2800, Denmark, Email: LF@COM.DTU.DK, *Now with Tellabs Denmark A/S.

- [5] Chen Yu, Xiaohong Jiang, Susumu Horiguchi, Minyi Guo, "Overall Blocking Behavior Analysis of General Banyan-Based Optical Switching Networks" IEEE Transactions on Parallel and Distributed Systems, Vol. 17, No. 9, September 2006.
- [6] Toshio Kiriara, Mari Ogawa, Hiroaki Inoue, and Koji Ishida "Lossless and Low-Crosstalk Characteristics in an InP-Based 2 x 2 Optical Switch" IEEE Photonics Technology letters, VOL. 5, NO. 9, September 1993.
- [7] C.Wu and T.Feng, "On a Class of Multistage Interconnection Networks," IEEE. Trans. Comput., Aug. 1980, pp.694-702.
- [8] Young Wook Keum and Sung Chun Kim, "Design and Analysis of the High-Performance Interconnected Banyan Switching Fabric (IBSF)", IEEE Trans. 1087-4089/96, 1993. pp. 249-255.
- [9] Jongwoon Park, Xun Li and Wei-Ping Huang, "Performance Simulation and Design Optimization of Gain-Clamped Semiconductor Optical Amplifiers Based on Distributed Bragg Reflectors", IEEE Journal of Quantum Electronics, Vol. 39, No. 11, November 2003, pp. 1415-1423.



Ghanshyam Singh completed his B.Tech from REC Silchar, M.Tech from MNIT Jaipur and is currently pursuing PhD from MNIT Jaipur. His areas of interest include photonics, Optical Communication, Optical Switches & Interconnections.



Tirtha Pratim Bhattacharjee is currently pursuing B.Tech from MNIT Jaipur. His fields of interests are optical communication and photonics.



R. P. Yadav completed his Master of Science and Master of Technology from IIT Delhi and Ph.D. degree from MNIT Jaipur. He is currently working as the head of Deptt. of ECE, MNIT. His areas of interest are Digital and Wireless Communication and Coding, Antennas, Optics, Networking.



Vijay Janyani completed his B.E and M.E from MREC Jaipur and received his PhD from Nottingham University, UK. His areas of interest include Optoelectronics, Nonlinear Optic and Numerical Modeling.