

A Low-Voltage Tunable Channel Selection Filter for WiMAX Applications

Kayvan Ahmadi, Hossein Shamsi

Abstract—This paper proposes a low-voltage and low-power fully integrated digitally tuned continuous-time channel selection filter for WiMAX applications. A 5th-order elliptic low-pass filter is realized in a Gm-C topology. The bandwidth of the fully differential filter is reconfigurable from 2.5MHz to 20MHz (8x) for different requirements in WiMAX applications. The filter is simulated in a standard 90nm CMOS process. Simulation results show the THD (@V_{out} =100mV_{pp}) is less than -66dB. The in-band ripple of the filter is about 0.15dB. The filter consumes 1.5mW from a supply voltage of 0.9V.

Keywords—Common-mode feedback, continuous-time, fully differential transconductor, Gm-C topology, low-voltage

I. INTRODUCTION

WORLDWIDE Interoperability for Microwave Access (WiMAX) technology, according to IEEE 802.16 standards, attracts people's attention recently. It provides fixed, nomadic, portable, and mobile wireless broadband connectivity no matter in a Line-of-Sight (LOS) or Non-Line-of-Sight (NLOS) environment. WiMAX can theoretically support data rate up to 70Mb/s and maximum coverage of 50km. The channel bandwidth is adjustable from 1.25MHz to 20MHz. Therefore, a channel selection filter with variable bandwidth is required for WiMAX applications [1]. Direct conversion architecture is appropriate for these systems because it does not need IF-SAW channel selection filters and subsequent down-conversion stages which are replaced with low-pass filters (LPFs) and baseband amplifiers [2]. In particular, Gm-C tuning is a fairly popular method because of its potential benefits of high speed and low-power. They have recently received great interest since they are suitable for integration and can operate at high frequencies. Although onchip active filters consume power, chip area, and limit the overall dynamic range, they enable high integration and bandwidth tuning. Therefore, the design of highly linear and tunable transconductors has become mandatory. In these filters, a fully differential transconductor circuit provides a suitable transconductance value. To achieve a variable bandwidth in Gm-C filters, either the transconductance or the capacitance is held constant while the other is tuned. In this work, all of the transconductors have a constant

transconductance and all of the capacitors can vary to achieve the desired cutoff frequencies.

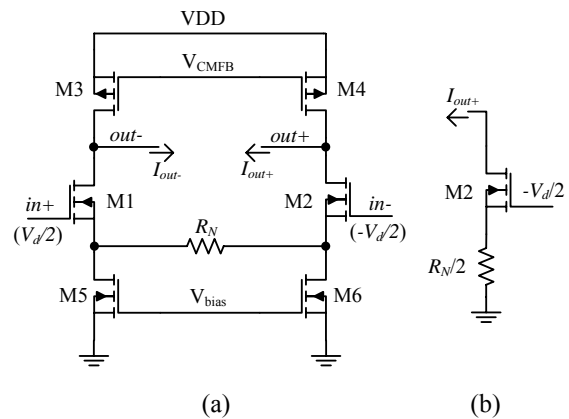

Fig. 1 (a) fully differential source degenerated transconductor, (b) the half circuit of the transconductor

II. FULLY DIFFERENTIAL SOURCE DEGENERATED TRANSCONDUCTOR

In new technology CMOS processes, short channel effects aren't negligible. They damage the linearity of the circuits. Making use of the fully differential circuits gives better performances in noise, linearity and etc compared with the single ended circuits. Thus, we have to use a fully differential transconductor to achieve better performances [3]-[4]. In an ideal transconductor, the output current is proportional to the input voltage. The relation is shown in (1).

$$I_{out} = G_m V_{in} \quad (1)$$

where I_{out} is the output current and V_{in} is the input voltage of the transconductor. The parameter G_m is a constant coefficient that denotes the transconductance value of the transconductor. In an ideal transconductor, the value of G_m is independent from the amplitude and frequency of the input signal.

Fig. 1 (a) shows a fully differential constant-Gm source degenerated transconductor. All of its transistors operate in the saturation region. M3 and M4 operate as two current sources and M5 and M6 operate as two current sinks. M1 and M2 and resistor R_N convert the differential input voltage to the differential output current. In order to have a balanced

Kayvan Ahmadi is with Islamic Azad University, Qazvin Branch, Qazvin, Iran (e-mail: kayvan_ahmadi@hotmail.com).

Hossein Shamsi is with the Faculty of Electrical Engineering, K.N.Toosi University of Technology, Tehran, Iran (e-mail: shamsi@eetd.kntu.ac.ir).

circuit, the size of transistors M1, M3 and M5 are chosen identical to that of M2, M4 and M6, respectively.

The transconductor operates as follows: The bias current through both branches of the transconductor is fixed by p-MOS transistors M3 and M4. Whenever the differential input signal is zero, the currents of both branches of the transconductor are equal. When the input signal is applied to the gate of M1 and M2, the currents of both branches become different because the input transistors M1 and M2 translate the input voltage to the degeneration resistor. The resistor current is then steered to the high impedance output nodes. This degenerated device is used to provide V to I conversion with high linearity. The main reasons of the distortion of the transconductor are the input transistors M1 and M2 and the implementation of the degeneration resistor [5]. The best choice for improving the linearity is to employ a passive source degeneration resistor.

The half circuit of the transconductor is shown in Fig. 1 (b) where $V_d = V_{in}$ is the input differential voltage of the transconductor. The output current of the transconductor is

$$I_{out+} = -g_{m2} v_{gs2} \quad (2)$$

where g_{m2} is the transconductance of the transistor M2 and v_{gs2} is its gate-to-source small signal voltage. So, we have

$$v_{gs2} = v_{g2} - v_{s2} = -\frac{V_d}{2} - \left(-\frac{R_N I_{out+}}{2} \right) \quad (3)$$

where v_{g2} and v_{s2} are the gate voltage and the source voltage of the transistor M2, respectively. From (1)-(3), we have

$$\frac{I_{out+}}{V_d} = \frac{1}{2} \cdot \frac{g_{m2}}{1 + g_{m2} R_N / 2} \quad (4)$$

similar to I_{out+} , we have

$$\frac{I_{out-}}{V_d} = \frac{1}{2} \cdot \frac{-g_{m1}}{1 + g_{m1} R_N / 2} \quad (5)$$

where g_{m1} is the transconductance of the transistor M1. From (4) and (5) and assuming $g_{m1} = g_{m2}$, the transconductance value of the transconductor is obtained as follows:

$$G_m = \frac{I_{out}}{V_{in}} = \frac{I_{out+} - I_{out-}}{V_{in+} - V_{in-}} = \frac{g_{m1}}{1 + g_{m1} R_N / 2} \quad (6)$$

where the $(I_{out+} - I_{out-})$ is the output differential current and the $(V_{in+} - V_{in-})$ is the input differential voltage.

The above fully differential circuit needs a common-mode feedback (CMFB) circuit to stabilize the output DC voltage

level of the transconductor according to a reference voltage (V_{REF}) [6]. V_{CMFB} is generated by a CMFB circuit to set the output DC level of the transconductor. Fig. 2 shows a low-voltage continuous-time CMFB circuit. The output of the op-amp is applied to the circuit of Fig. 1 at node V_{CMFB} . The nodes $out+$ and $out-$ have to be connected to the nodes $out+$ and $out-$ in Fig. 1, respectively [6]. The source voltages of the transistors M9 (V_{s9}) and M10 (V_{s10}) are

$$V_{s9} = V_{out-} - V_{gs7} - V_{gs9} \quad (7)$$

$$V_{s10} = V_{out+} - V_{gs8} - V_{gs10} \quad (8)$$

and the voltage of node CM (V_{CM}) is

$$V_{CM} = V_{s9} - R I_R \quad (9)$$

where I_R is the current of resistor R which is

$$I_R = \frac{V_{s9} - V_{s10}}{2R} \quad (10)$$

from (5)-(8), the V_{CM} is obtained as follows:

$$V_{CM} = V_{CM1} + V_{CM2} \quad (11)$$

$$V_{CM1} = -\frac{V_{gs9} + V_{gs10} + V_{gs7} + V_{gs8}}{2} \quad (12)$$

$$V_{CM2} = \frac{V_{out+} + V_{out-}}{2} \quad (13)$$

The voltage of node CM consists of two terms V_{CM1} and V_{CM2} that the first term V_{CM1} is independent from the voltage of nodes $out-$ and $out+$. It is only dependent on bias currents of M7, M8, M9 and M10. The second term V_{CM2} is only dependent on the common-mode voltage of nodes $out-$ and $out+$. When the output DC voltage level of the transconductor increases, the voltage of the node CM increases, too. The op-amp compares the increased common-mode voltage with the reference voltage which is applied to the op-amp (V_{REF}) and increases the voltage V_{CMFB} . Increasing the voltage V_{CMFB} causes decreasing the output DC voltage level of the transconductor of Fig. 1. This means that the CMFB circuit has a negative feedback. If

$$V_{REF} = V_{CM1} + V_{desired} \quad (14)$$

The CMFB circuit sets the output DC voltage level to the voltage $V_{desired}$.

Fig. 3 shows the simple op-amp used in CMFB circuit. It is a differential amplifier with an active load to have high voltage gain.

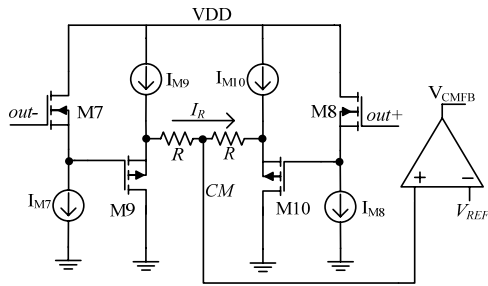

Fig. 2 Common-mode feedback circuit

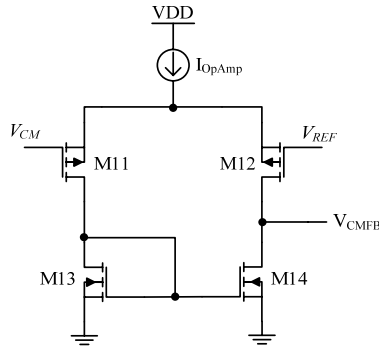

Fig. 3 The simple op-amp used in CMFB circuit

III. 5th-order Elliptic LPF Design

A. Filter Design

The main characteristic of an elliptic filter is its sharp magnitude response compared with the other filters such as Butterworth, Bessel and etc. The biquad circuit realization for the filter is used because of its advantages in design and layout. Furthermore, this approach compared to the ladder filters has the advantage that the filter is not a single complicated structure but the cascade of simple blocks. A disadvantage of the biquad filters compared to the ladder filters has the larger sensitivity to the component variations [7].

The normalized ($\omega_0 = 1$) transfer function of the 5th-order elliptic filter is

$$H(S) = H_1(S) \cdot H_2(S) \cdot H_3(S) \quad (15)$$

where the H_1 , H_2 and H_3 are

$$H_1(S) = \frac{(0.043S^2 + 0.36)}{(S^2 + 0.77S + 0.52)} \quad (16)$$

$$H_2(S) = \frac{(0.043S^2 + 0.92)}{(S^2 + 0.28S + 0.94)} \quad (17)$$

$$H_3(S) = \frac{0.73}{(S + 0.50)} \quad (18)$$

Fig. 4 shows a 5th-order elliptic low-pass filter. The filter is made by four cascaded blocks. The first block H_1 is a biquad filter with two zeroes and the second block is a fully differential unity gain amplifier. The third block H_2 is a biquad filter with

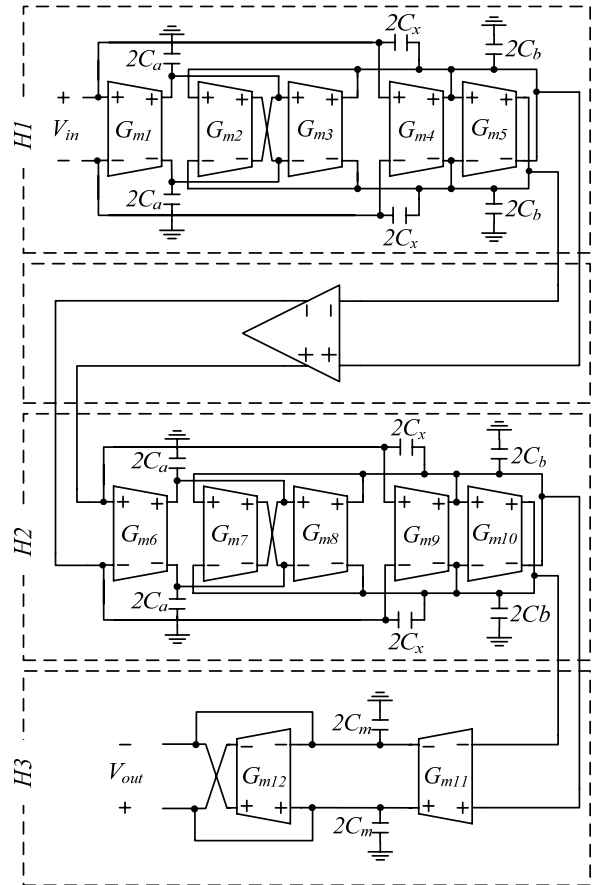

Fig. 4 A 5th-order elliptic low-pass filter

two zeroes and the last block H_3 is a 1st-order filter without any zero [2]. The transfer function of the biquad Gm-C filters (H_1 and H_2) is

$$H(S) = \frac{K_2 S^2 + K_1 S + K_0}{S^2 + \left(\frac{\omega_0}{Q}\right)S + \omega_0^2} \quad (19)$$

$$K_2 = \left(\frac{C_x}{C_x + C_b}\right); \quad K_1 = \left(\frac{G_{m4}}{C_x + C_b}\right); \quad K_0 = \left(\frac{G_{m1} G_{m3}}{C_a (C_x + C_b)}\right)$$

$$\frac{\omega_0}{Q} = \left(\frac{G_{m5}}{C_x + C_b}\right); \quad \omega_0^2 = \left(\frac{G_{m2} G_{m3}}{C_a (C_x + C_b)}\right) \quad (20)$$

the transfer function of the 1st-order low-pass Gm-C filter (H_3) is

$$H_3(S) = \frac{\left(\frac{G_{m11}}{C_m}\right)}{S + \left(\frac{G_{m12}}{C_m}\right)} \quad (21)$$

From (13)-(15), the desired transconductance values of the

Gm-C filter are obtained as shown in table I. In order to avoid loading effects of block H_2 on block H_1 , a fully differential amplifier with high input impedance and low output impedance is placed between them. This amplifier is shown in Fig. 5. The amplifier is made by a differential pair with diode connected load transistors.

B. Cutoff Frequency Tuning

By varying the capacitors, the corner frequency of the filter will change. Fig. 6 shows a 2'bits digitally tuned capacitor array [7]. Table II shows the relation between input control bits status and total equivalent capacitance of the array. When a control bit goes to '1', the MOS transistor which is connected to the control bit, goes to triode region and the total capacitance of the capacitor array increases. If all of the control bits are '0', the capacitance of the variable capacitor has its lowest value that gives the maximum cutoff frequency. When two control bits are '1', the capacitance of the variable capacitor has its highest value that gives the minimum cutoff frequency of the filter. The desired capacitance values of the capacitor array are shown in table III.

TABLE I

THE DESIRED TRANSCONDUCTANCE VALUES OF THE GM-C FILTER

G_{m1}	37.6 μ S	G_{m7}	72.6 μ S
G_{m2}	54.2 μ S	G_{m8}	74.3 μ S
G_{m3}	55.5 μ S	G_{m9}	0
G_{m4}	0	G_{m10}	21.2 μ S
G_{m5}	59.2 μ S	G_{m11}	54.5 μ S
G_{m6}	71.4 μ S	G_{m12}	37.2 μ S

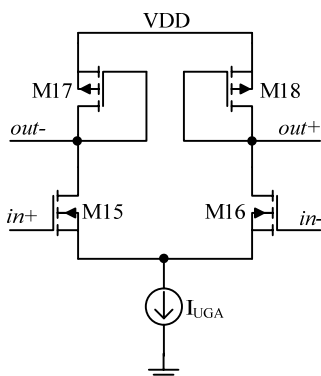

Fig. 5 A fully differential amplifier with high input impedance and low output impedance

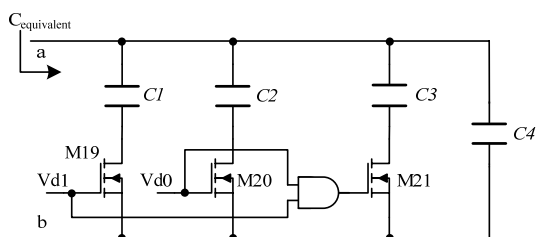

Fig. 6 A 2'bits digitally tuned capacitor array

TABLE II

RELATION BETWEEN THE CONTROL BITS STATUS AND THE TOTAL CAPACITANCE OF THE CAPACITOR ARRAY

'Vd1 Vd0'	$C_{equivalent}$	Cutoff freq.
00	$C4$	20MHz
01	$C4+C2$	10MHz
10	$C4+C1$	5MHz
11	$C4+C2+C1+C3$	2.5MHz

TABLE III

THE DESIRED CAPACITOR VALUES OF THE CAPACITOR ARRAY

	C_a, C_m	C_b	C_x
$C1$	3.3 pF	3.6pF	162fF
$C2$	1.1pF	1.1pF	50fF
$C3$	3.6 pF	3.42pF	154fF
$C4$	1.2pF	1.1pF	50fF

IV. SIMULATION RESULTS

Making use of the described fully differential transconductor, the above 5th-order elliptic LPF is simulated with HSPICE in a 90nm CMOS technology. The supply voltage of the filter is 0.9V. Fig. 7 shows the differential output current of the transconductor ($I_{out} = I_{out+} - I_{out-}$) versus the differential input voltage of the transconductor. Fig. 8 shows the simulated large signal transconductance value of the transconductor as a function of the differential input voltage, where RN varies from 5k Ω to 24k Ω . The frequency response of the normalized transconductance (G_m/G_{m0}) is depicted in Fig. 9. In this simulation we have: $G_{m0}=35\mu$ S. In Fig. 10 the frequency response of the filter is shown. In order to achieve the required tuning range, capacitors are switched so that the cutoff frequencies (f_c) are tuned from 2.5MHz to 20MHz corresponding to the digital tuning inputs. In Fig. 11 the THD of the output voltage of the filter versus the peak-to-peak amplitude of the input signal of the filter is depicted. Table IV summarizes the simulation results of the filter

V. CONCLUSIONS

A fully differential, fully integrated, low-voltage, and low-power Gm-C filter has been simulated in a standard 90nm CMOS process. To avoid the short channel effects, the filter has been made by using a fully differential constant-Gm transconductor. The filter consumes 1.5mW from a supply voltage of 0.9V. The corner frequency of the filter can be adjusted between 2.5MHz and 20MHz by applying 2'bits digital inputs.

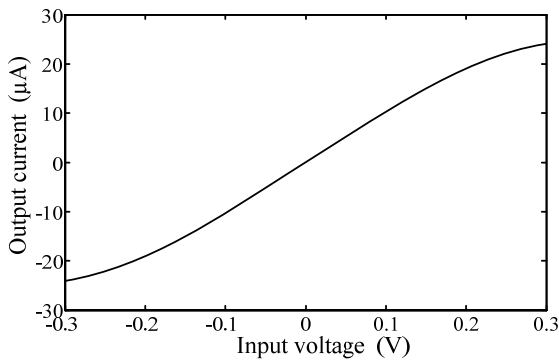

Fig. 7 The differential output current of the transconductor versus its differential input voltage

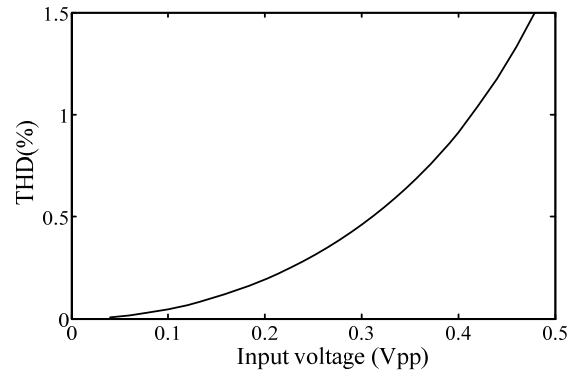

Fig. 11 THD versus input voltage of the filter

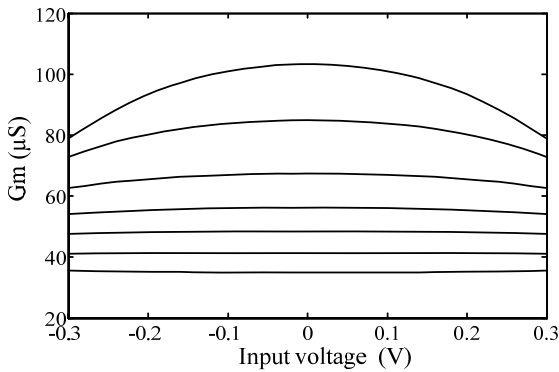

Fig. 8 Transconductance (G_m) versus the differential input voltage of the transconductor

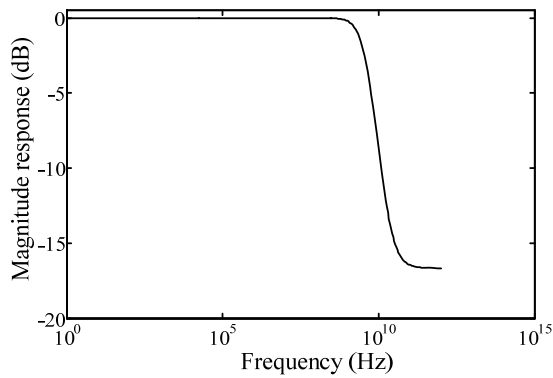

Fig. 9 Normalized transconductance (G_m/G_{m0}) frequency response ($G_{m0}=35\mu S$)

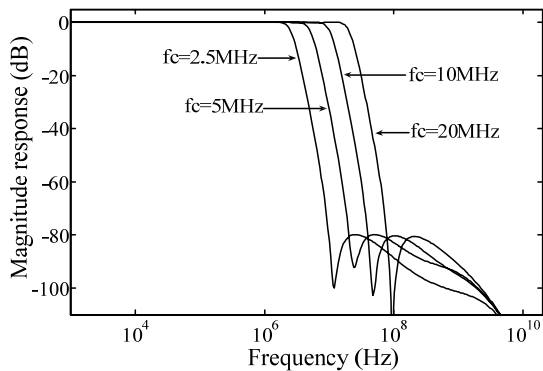

Fig. 10 Magnitude response of the filter

TABLE IV

SIMULATION RESULTS OF THE FILTER

Technology	90nm CMOS
Supply voltage	0.9V
Filter type	5 th -order elliptic
Tuning range of f_c	2.5MHz – 20MHz (8x)
In-band ripple	0.15dB
Total input eq. noise	462 μ Vrms
THD (@ $V_{out}=100mV_{pp}$)	-66dB
Att. (@ $f_{stop}=4\times f_c$)	79dB
Power consumption	1.5mW

REFERENCES

- [1] D.-R. Huang, S.-W. Kao, and Y.-H. Pang, "A WiMAX Receiver with Variable Bandwidth of 2.5 – 20 MHz and 93 dB Dynamic Gain Range in 0.13- μ m CMOS Process", *IEEE Radio Frequency Integrated Circuits Symposium*, June 2007, pp. 369-372.
- [2] S. Hori, T. Maeda, H. Yano, N. Matsuno, K. Numata, N. Yoshida, Y. Takahashi, T. Yamase, R. Walkington, and H. Hida, "A Widely Tunable CMOS Filter With Negative Source Degeneration Resistor Transconductor", *IEEE Solid-State Circuits Conference*, Sept. 2003, pp. 449-452.
- [3] J. Jiang; Y. Wang, "Design of A Tunable Frequency CMOS Fully Differential Fourth-order Chebyshev Filter", *Elsevier, Microelectronics Journal*, vol. 37, June 2006, pp. 84-90.
- [4] D.A. Johns and K.W. Martin, *Analog Integrated Circuit Design*, Wiley, New York, 1997.
- [5] T. Sanchez-Rodriguez, C.I. Lujan-Martinez, R.G. Carvajal, J. Ramirez-Angulo and A. Lopez-Martin, "CMOS Linear Programmable Transconductor Suitable For Adjustable Gm-C Filters", *Electronics Letters*, vol. 44, no. 8, April 2008, pp. 505-506.
- [6] E. Sanchez-Sinencio, "Common-mode Feedback Techniques: A Tutorial", *Texas A&M University*, Feb. 2005.
- [7] U. Stehr, F. Henkel, L. Dalluge, P. Waldow, "A Fully Differential CMOS Integrated 4th Order Reconfigurable Gm-C Lowpass Filter for Mobile Applications", *IEEE International Conference on Electronics, Circuits and Systems (ICECS)*, vol. 1, Dec. 2003, pp. 144-147.