

# Despeckling of Synthetic Aperture Radar Images Using Inner Product Spaces in Undecimated Wavelet Domain

Syed Musharaf Ali, Muhammad Younus Javed, Naveed Sarfraz Khattak, Athar Mohsin, and Umar Farooq

**Abstract**—This paper introduces the effective speckle reduction of synthetic aperture radar (SAR) images using inner product spaces in undecimated wavelet domain. There are two major areas in projection onto span algorithm where improvement can be made. First is the use of undecimated wavelet transformation instead of discrete wavelet transformation. And second area is the use of smoothing filter namely directional smoothing filter which is an additional step. Proposed method does not need any noise estimation and thresholding technique. More over proposed method gives good results on both single polarimetric and fully polarimetric SAR images.

**Keywords**—Directional Smoothing, Inner product, Length of vector, Undecimated wavelet transformation.

## I. INTRODUCTION

SYNTHETIC aperture radar is a radar technology that is used from satellite or airplane. It produces high resolution images of earth's surface by using special signal processing techniques. Synthetic aperture radar has important role in gathering information about earth's surface because it can operate under all kinds of weather condition (whether it is cloudy, hazy or dark). However acquisition of SAR images face certain problems. SAR images contain speckle noise which is based on multiplicative noise or rayleigh noise.

Speckle noise is the result of two phenomenon, first phenomenon is the coherent summation of the backscattered signals and other is the random interference of electromagnetic signals [2]. Speckle noise degrades the appearance and quality of SAR images. Ultimately it reduces the performances of

Syed Musharaf Ali did MS in Software engineering from College of Signals, National University of Sciences and Technology, Rawalpindi, Pakistan (e-mail: musharaf@mcs.edu.pk).

Muhammad Younus Javed did his PhD from UK. Now he is head of department of Department of Computer engineering at college of electrical and mechanical engineering, National University of Sciences and Technology, Rawalpindi, Pakistan (e-mail: myjaved@ceme.edu.pk).

Naveed Sarfraz Khattak did his MS from Michigan State University (U.S.A). Now he is Head of Department of Computer Science Department at College of Signals, National University of Sciences and Technology, Rawalpindi, Pakistan (e-mail: naveed-khattak@mcs.edu.pk).

Athar Mohsin Zaidi is a assistant professor at College of Signals, National University of Sciences and Technology, Rawalpindi, Pakistan (e-mail: athar-mcs@nust.edu.pk).

Umer Farooq is a Lecturer at College of Signals, National University of Sciences and Technology, Rawalpindi, Pakistan (e-mail: umar-mcs@nust.edu.pk).

important techniques of image processing such as detection, segmentation, enhancement and classification etc. That is why speckle noise should be removed before applying any image processing technique.

There are three main objectives of any speckle filtering. First is to remove noise in uniform regions. Second is to preserve and enhance edges and image features and third is to provide a good visual appearance. Unfortunately 100% speckle reduction is not possible. Therefore, tradeoff has to be made among these requirements. Speckle reduction usually consists of three stages [3] First stage is to transform the noisy image to a new space (frequency domain). Second stage is the manipulation of coefficients. Third is to transform the resultant coefficients back to the original space (spatial domain). Currently many statistical filters are available for speckle reduction. Such as Mean, Kuan, Frost, Lee and MAP filter etc. Results show that statistical filters are good in speckle reduction but they also lose important feature details. Additionally prior knowledge about noise statistics is a prerequisite for statistical filters.

In recent years, there has been active research on wavelet-based speckle reduction because wavelet provides multi resolution decomposition and analysis of image. In wavelet sub bands noise is present in small coefficients and important feature details are present in large coefficients. If small coefficients are removed, we will get noise free image.

Previously most of the researchers use discrete wavelet transformation [1]-[8] for reduction of speckle. Draw back of discrete wavelet transformation is that it is not translation invariant [9]. That means it will lose lots of important coefficients during translation from original signal to sub bands. In order to solve this problem and to save the coefficients, derived form of discrete wavelet transformation is used called undecimated wavelet transformation. Basic idea is that it does not lose any coefficients, all coefficients remain intact. That is why it is also called redundant wavelet transformation. It requires more storage space and need more time for computation.

Whether discrete or stationary wavelet is used, biggest problem is the selection of optimal thresholding. Some researchers use wavelet based hard or soft thresholding [2], [10] Other thresholding techniques were also used such as VisuShrink, SureShrink, OracleShrink, OracleThresh,

NormalShrink, BayesShrink, Thresholding Neural Network (TNN) etc. [10]-[13]. But there are some drawbacks of using those thresholds as shown in [5].

Therefore there is a need of new technique that does not require any thresholding and gives better performance in terms of result, cost and complexity than other techniques that use different kinds of thresholding. In Section II speckle model for a SAR image is described. In section III introduction of undecimated wavelet transform is discussed. In section IV detail description of proposed algorithm is given that includes general information about Inner product, inner product space, Norm (Length) of Real Matrices, directional smoothing and proposed algorithm. In section V general overview about evaluation parameters is given. In section VI experimental results and their discussion is given. In section VII conclusion is made. Finally in the last references are given.

## II. SPECKLE MODEL FOR SAR IMAGES

Speckle noise is typically modeled as multiplicative noise (Rayleigh noise); therefore final output signal is the product of original signal and speckle noise.

Let  $I(i, j)$  be the degraded pixel of an observed image and  $S(i, j)$  is the noise-free image pixel to be recovered. With the multiplicative noise model,

$$I(i, j) = S(i, j) * N(i, j) \quad (1)$$

In which  $N(i, j)$  represents the multiplicative noise with unit mean and standard deviation [3].

Most of researchers convert multiplicative noise into additive noise by homomorphic filtering before speckle filtering of SAR images as shown in [6],[14] etc. But research shows that there is no significant impact of homomorphic filtering on any speckle filtering algorithm so it is not necessary to convert speckle noise to additive noise. Additionally, mean of log transformed speckle noise does not equal to zero. Therefore necessary corrections and adjustments have to be made before any further processing. So homomorphic filtering is not recommended step for speckle filtering. Homomorphic filtering is shown in Fig. 1.

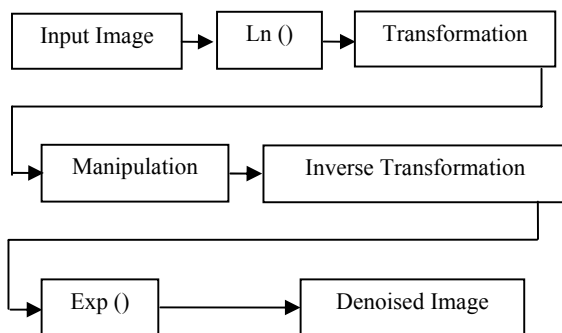

Fig. 1 Homomorphic filtering

## III. UNDECIMATED WAVELET TRANSFORMATION

The original technique [1], uses the discrete wavelet transformation, but for despeckling or denoising of images, use of discrete wavelet transformation is not encouraged due to two main reasons[5]. First reason is the down sampling by 2 in the DWT can produce aliasing and second reason is DWT is not shift-invariant or time invariant. Moreover down sampling leads to loss of many important coefficients that is not required in despeckling. On the other hand undecimated wavelet transform does not use down sampling so there is no aliasing problem. And it is shift invariant. Other major difference is that in undecimated wavelet sub band size is same as original image. If image size is  $r*c$ , then sub band size is also  $r*c$  instead of  $r/2*c/2$  as in the case of discrete wavelet. First level undecimated wavelet transform is shown in Fig. 2.

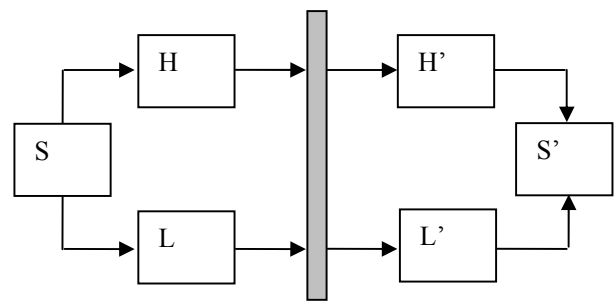

Fig. 2 First level undecimated wavelet transformation

Where  $S$  is the original signal,  $S'$  is the processed signal by undecimated wavelet transform,  $H$  and  $L$  are the high pass and low pass decomposition filters,  $H'$  and  $L'$  are the high pass and low pass reconstruction filters. Gray bar in the middle of figure 2 is the area where coefficients of wavelet sub bands can be manipulated for the proposed algorithms.

## IV. PROPOSED METHOD

Proposed method includes three sections. First section describes Inner product, inner product space and Norm (Length) of Real Matrices. Second section describes directional smoothing filter and third section describes original technique [1] with addition of undecimated wavelet transformation and directional smoothing function.

### A. Inner Product, Inner Product Space and Norm (Length) of Real Matrices

Let  $V$  be a vector space over the field  $F$  of real or complex numbers. A mapping  $\langle ., . \rangle: V*V \rightarrow F$  is said to be an inner product on  $V$ .

The pair  $(V, \langle ., . \rangle)$ , where  $V$  is a vector space over the field  $F$  of real or complex numbers and  $\langle ., . \rangle$  an inner product on  $V$ , is called an inner product space.

Let  $V$  be an inner product space and  $v \in V$  then the real number  $\sqrt{\langle v, v \rangle}$  is called the norm or (length) of  $v$  and is denoted by the symbol  $\|v\|$  [15].

**B. Directional Smoothing**

During despeckling process, edges are blurred so to protect edges from blurring directional smoothing filter is used [16].

- Select mask of size 3×3 or 5×5 or 7×7
- Take the average of pixels of each direction as shown in figure3 and store in array v(n) where n =4

$$v(m, n) = 1/R \sum_i \sum_j y(m-i, n-j) \quad (2)$$

- Find V1(n) such that

$$V1(n) = abs(v(n) - x(r, c)) \quad (3)$$

For each mask. Where x(r,c) is central pixel of mask.

- Find index of V1(n) that gives minimum value such that

$$Index = \min(V1) \quad (4)$$

- Replace the pixel value of x(r,c) by v(index)
- Repeat step 1 until whole image is scanned by mask.

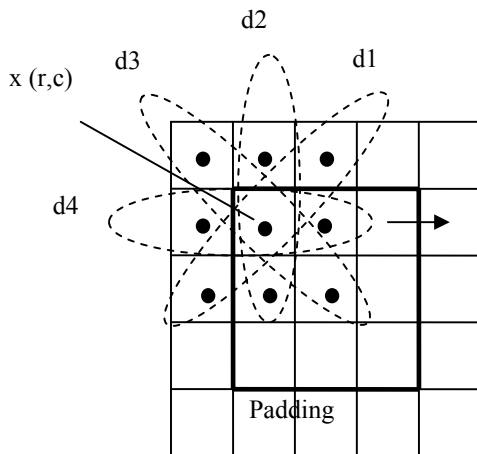

Fig. 3 Directional Smoothing Filter

**C. Proposed Algorithm**

First step is the decomposition of speckled SAR images into four wavelet sub bands ,approximation coefficients and detail coefficients (including horizontal ,vertical and diaganol coefficients) respectively by using two dimensional undecimated wavelet transformation say UDWT-2D.If original image of size r \* c is used then each sub band also has size r \* c instead of size r/2\* c/2. IUDWT-2D is the inverse undecimated wavelet transformation. Note algorithm in [1] uses discrete wavelet transformation. And change of wavelet can cause great difference in results.

Let {cA1, cH1, cV1, Cd1} be a basis for an inner product space. Then

$$cA = CA1 / \sqrt{\langle cA1, cA1 \rangle} \quad (5)$$

$$cH = CH1 / \sqrt{\langle cH1, cH1 \rangle} \quad (6)$$

$$cV = CV1 / \sqrt{\langle cV1, cV1 \rangle} \quad (7)$$

$$cH2 = \langle cH1, cA \rangle cA \quad (8)$$

$$cV2 = \langle cV1, cA \rangle cA + \langle cV1, cH \rangle cH \quad (9)$$

$$cD2 = \langle cD1, cA \rangle cA + \langle cD1, cH \rangle cH + \langle cD1, cV \rangle cV \quad (10)$$

In the next step process cH2, cV2, cD2 with directional smoothing function DS

$$cH3 = DS(cH2) \quad (11)$$

$$cV3 = DS(cV2) \quad (12)$$

$$cD3 = DS(cD2) \quad (13)$$

Despeckled image is the reconstructed image of cA1, cH3, cV3 and cD3 sub bands by inverse undecimated wavelet transform. There are two major advantages of this technique; first advantage is that, it does not need any threshold. Second advantage is that, it requires only first level of wavelet decomposition. Modified version of block diagram from [1] is shown in Fig. 4.

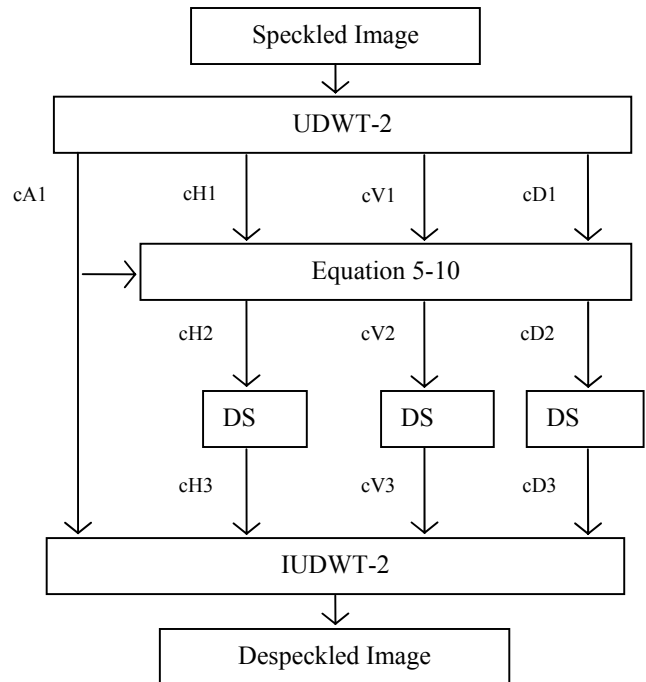

Fig. 4 Modified Block Diagram

### V. EVALUATION PARAMETERS

Algorithm performance is evaluated with the help of following evaluation parameters.

#### A. Mean Square Difference

MSD indicates average square difference of the pixels throughout the image between the original image (speckled) S and Despeckled image D. A lower MSD means that there is a significant filter performance. But small MSD values did not always correspond to good visual quality [7].

$$MSD = \frac{\sum (S(r,c) - D(r,c))^2}{R \times C} \quad (14)$$

Where R\*C is the size of image.

#### B. Peak Signal to Noise Ratio

The PSNR is most commonly used as a measure of quality of reconstruction in image compression and image denoising etc. The PSNR is given by

$$PSNR = \frac{10 \log_{10}(255)^2}{MSE} \quad (15)$$

Greater the value of PSNR, better the speckle reduction of images.

### VI. EXPERIMENTAL RESULTS

Experimental results are taken on original synthetic aperture radar images with added artificial speckle noise of variance 0.1. Data set for synthetic aperture radar is taken from Sandia National Laboratories website. Results are taken by executing original technique [1] and then executing proposed modified technique against six different images.

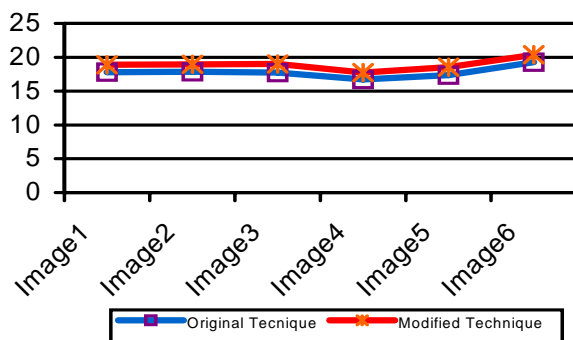

Fig. 5 Peak Signal to Noise Ratio

Fig. 5 shows that modified proposed method gives approximately 6% improvement in terms peak signal to noise

ratio as compared to original technique [1]. Note higher the value of peak signal to noise ratio, the better the results.

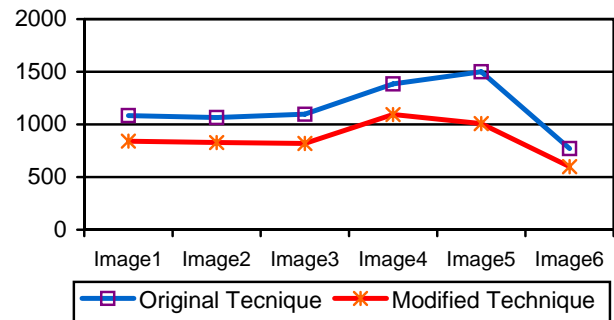

Fig. 6 Mean Square Difference

Fig. 6 shows that modified proposed method gives approximately 22% improvement in terms of mean square difference as compared to original technique [1]. Note lower the value of mean square difference, the better the results.

TABLE I  
 RESULTS FOR DESPECKLING IN TERMS OF PSNR AND MSD

Technique	PSNR	MSD
<b>Proposed Algorithm</b>	<b>19.2825</b>	<b>767.06</b>
<b>Original Technique[1]</b>	<b>18.2067</b>	<b>982.66</b>
Kuan Filter	17.7317	1096.2
Lee Filter	17.7267	1097.5
Homomorphic Kuan Filter	17.4639	1166.0
Homomorphic Lee Filter	17.4542	1168.6
Frost Filter	16.8922	1330
Homomorphic Frost Filter	16.7592	1371.4
Mean Filter	17.8248	1073
Homomorphic Mean Filter	17.4243	1176.6
Hard Threshold	18.0867	1096.3
Soft Threshold	18.0245	1079.6
Bayesian Threshold	17.0558	1280.8
Normal Threshold	17.0267	1289.5
Universal Threshold	17.0439	1284.4
Visu Threshold	17.0370	1286.4

Table I compares the proposed technique with original technique and some other common techniques that can be used for speckle filtering of SAR images. Results show that the proposed method gives better results than all the given techniques. Flow chart for the proposed algorithm is shown in Fig. 7.

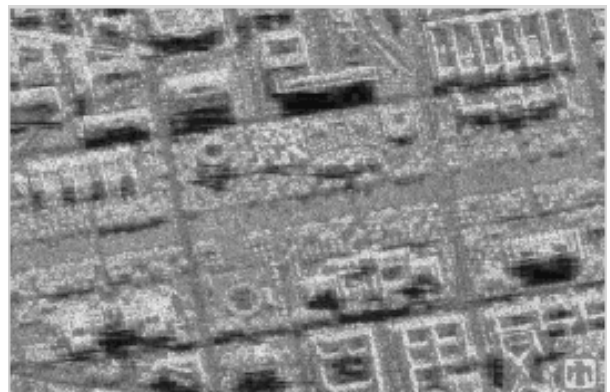
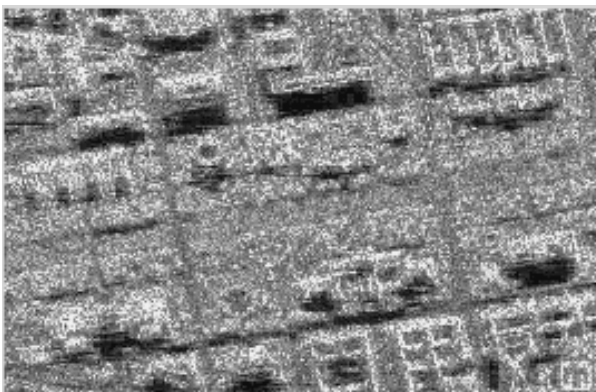
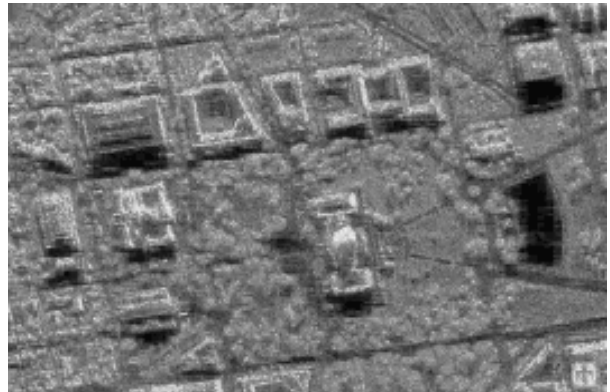
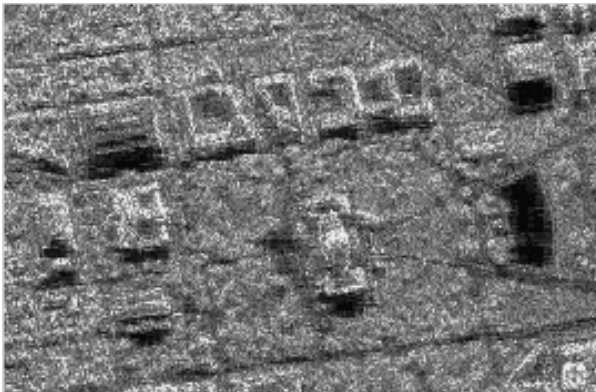
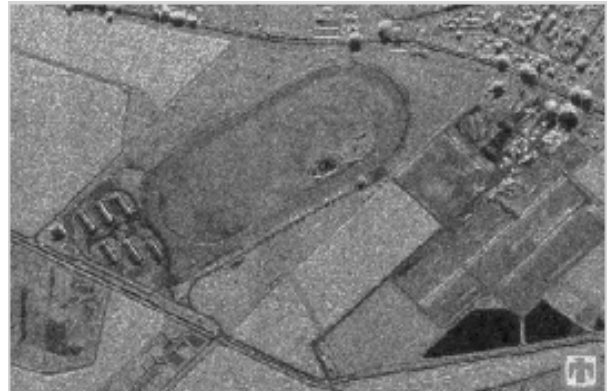
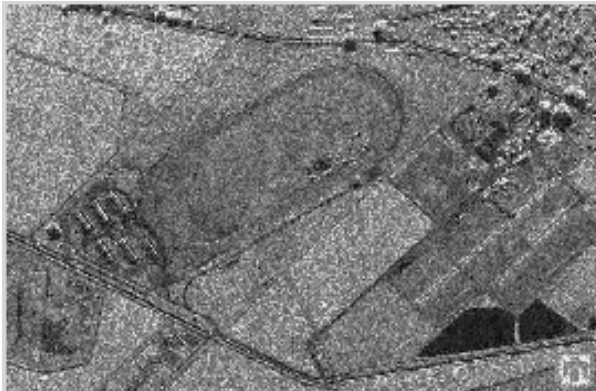
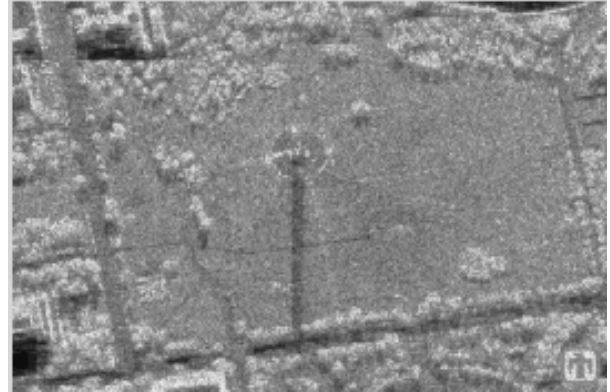
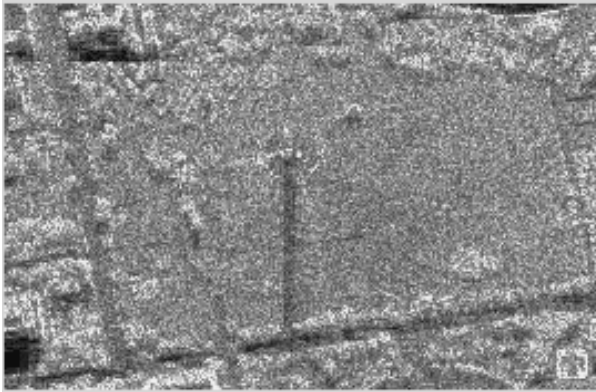

Speckled SAR Images

Despeckled SAR Images

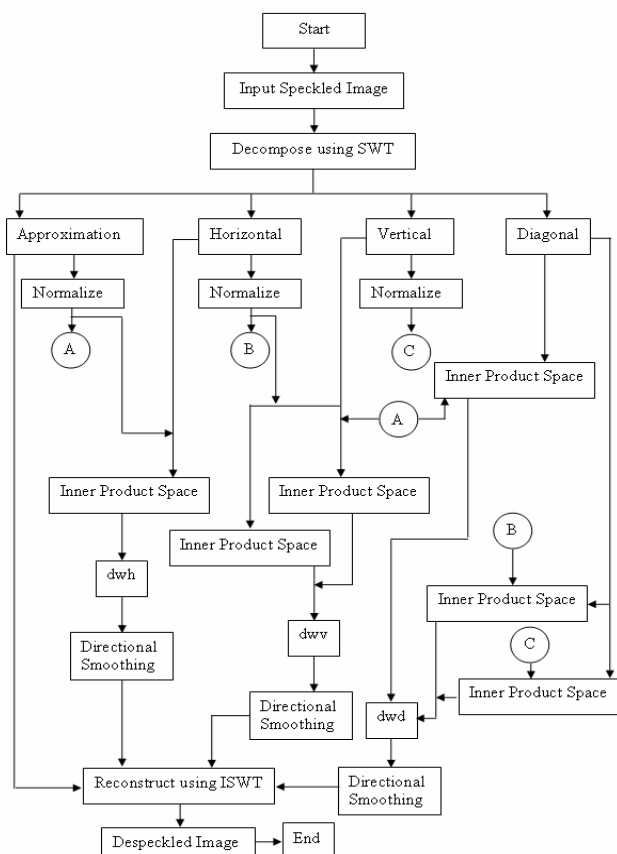

Fig. 7 Flow Chart

## VII. CONCLUSION

In this paper, we tried to improve the technique for speckle reduction of SAR images as given in [1]. Two major changes we made in the original technique. First we use undecimated discrete wavelet transformation while originally discrete wavelet transformation is used. Because undecimated discrete wavelet is more appropriate for speckle reduction or noise removal as compared to discrete wavelet. Second change is the introduction of directional smoothing filter. Directional smoothing filter is applied to each detail sub band just before reconstruction of wavelet sub bands. Results show that these changes gives 6% improvement in peak signal to noise ratio and 22% improvement in mean square difference as compared to original technique.

## REFERENCES

- [1] Mario Mastriani, "New Wavelet-Based Super resolution Algorithm for Speckle Reduction in SAR Images". International journal of computer science (IJCS), Vol 1, ISSN 1306-4428-2006, pp.291-298, 2006.
- [2] Saevarsson, B.B, Sveinsson, J.R, Benediktsson J.A, "Combined Wavelet and Curvelet Denoising of SAR Images", IEEE Transactions on Geosciences and Remote Sensing, Vol 6, pp. 4235-4238, Sept 2004.
- [3] Guozhong Chen, Xingzhao Liu "Wavelet-Based Despeckling SAR Images Using Neighbouring Wavelet Coefficients" IEEE conference on RADAR, Vol 3, pp.212-216, 2005.
- [4] Guozhong Chen, Xingzhao Liu, "An Improved Wavelet -Based Method for SAR image Denoising Using Data Fusion" IEEE conference on RADAR, Vol. 6, pp. 818-822, April 2006.
- [5] D. Lee Fugal, "Conceptual Wavelets in Digital Signal Processing", 2007.

- [6] M. I. H. Bhuiyan, M. Omair Ahmed M. N. S. Swamy, "Wavelet-based Spatially Adaptive Method for Despeckling SAR Images", IEEE International Symposium on Circuits and Systems, ISCAS, Vol. 10, pp.1109-1112, May 2006.
- [7] Sheng Guofang, Hu Xin, Jiao Licheng, "SAR Image Denoising based on Data Fusion", Proceedings of the fifth computational intelligence and multimedia applications ICCIMA, Vol 10, pp.143-148, Sept 2003.
- [8] Aglika Gyaourova "Undecimated Wavelet Transforms for Image Denoising" center for applied scientific computing, Lawrence Livermore nation laboratory, November 19, 2002.
- [9] D.L. Donoho, "Denoising by soft Thresholding," IEEE Trans. on Inform Theory, vol. 41, pp. 613-627, May 1995.
- [10] H.S. Tan, "Denoising of Noise Speckle in Radar Image", Oct 2001.
- [11] H. Guo, J.E. Odegard, M. Lang, R.A. Gopinath, I. Selesnick, and C.S. Burrus, "Speckle reduction via wavelet shrinkage with application to SAR based ATD/R," Technical Report CML TR94-02, CML, Rice University, Houston, 1994.
- [12] D.L. Donoho and I.M. Johnstone, "Adapting to unknown smoothness via wavelet shrinkage," Journal of the American Statistical Association, vol. 90, no. 432, pp. 1200-1224, 1995.
- [13] S.G. Chang, B. Yu, and M. Vetterli, "Adaptive wavelet thresholding for image denoising and compression," IEEE Transactions on Images Processing, vol 9, no. 9, pp.1532-1546, September 2000.
- [14] X. P. Zhang, "Thresholding Neural Network for Adaptive Noise reduction," IEEE Transactions on Neural Networks, vol.12, no.3, pp.567-584, May 2001.
- [15] S. M. Yusuf, Abdul Majeed, Muhammad Amin "Mathematical Methods" 2000.
- [16] Anil K. Jain "Fundamentals of Digital Image Processing. 2004.