

# An Effective Approach for Distribution System Power Flow Solution

A. Alsaadi, and B. Gholami

**Abstract**—An effective approach for unbalanced three-phase distribution power flow solutions is proposed in this paper. The special topological characteristics of distribution networks have been fully utilized to make the direct solution possible. Two matrices—the bus-injection to branch-current matrix and the branch-current to bus-voltage matrix— and a simple matrix multiplication are used to obtain power flow solutions. Due to the distinctive solution techniques of the proposed method, the time-consuming LU decomposition and forward/backward substitution of the Jacobian matrix or admittance matrix required in the traditional power flow methods are no longer necessary. Therefore, the proposed method is robust and time-efficient. Test results demonstrate the validity of the proposed method. The proposed method shows great potential to be used in distribution automation applications.

**Keywords**—Distribution power flow, distribution automation system, radial network, unbalanced networks.

## I. INTRODUCTION

AS an important tool and the foundation of Distribution Management System (DMS), power flow calculation problem has been paid more and more attention. Many programs of real-time applications in the area of distribution automation, such as network optimization planning, switching, state estimation, and so forth, require a robust and efficient power flow method [1]–[3]. Such a power flow method must be able to model the special features of distribution systems in sufficient detail. The well-known characteristics of an electric distribution system are radial; multiphase and unbalanced operation; unbalanced distributed load; extremely large number of branches and nodes; wide-ranging resistance and reactance values. Those features cause the traditional power flow methods used in transmission systems, such as the Gauss-Seidel and Newton-Raphson techniques, to fail to meet the requirements in both performance and robustness aspects in the distribution system applications. In particular, the assumptions necessary for the simplifications used in the standard fast-decoupled Newton-Raphson method [4] often are not valid in distribution systems. Therefore, a novel power flow algorithm for distribution systems is desired. To qualify for a good distribution power flow algorithm, all of the characteristics mentioned before, need to be considered. Several power flow

algorithms specially designed for distribution systems have been proposed in the literature [5]–[13].

Some of these methods were developed based on the general meshed topology like transmission systems [5]–[9]. From those methods, the Gauss implicit -matrix method [7] is one of the most commonly used methods; however, this method does not explicitly exploit the radial network structure of distribution systems and, therefore, requires the solution of a set of equations whose size is proportional to the number of buses. Recent research proposed some new ideas on how to deal with the special topological characteristics of distribution systems [10]–[15], but these ideas require new data format or some data manipulations. In [10], the authors proposed a compensation-based technique to solve distribution power flow problems. Branch power flows rather than branch currents were later used in the improved version and presented in [11]. Since the forward/backward sweep technique was adopted in the solution scheme of the compensation-based algorithm, new data format and search procedure are necessary. Extension of the method, which emphasized on modeling unbalanced loads and dispersed generators, was proposed in [12]. In [13], the feeder lateral based model was adopted, which required the “layer-lateral” based data format. One of the main disadvantages of the compensation-based methods is that new databases have to be built and maintained. In addition, no direct mathematical relationship between the system status and control variables can be found, which makes the applications of the compensation-based algorithm difficult.

The algorithm proposed in this paper is a novel technique. The only input data of this algorithm is the conventional bus-branch oriented data used by most utilities. The goal of this paper is to develop a formulation, which takes advantages of the topological characteristics of distribution systems, and solve the distribution power flow directly. It means that the time-consuming LU decomposition and forward/backward substitution of the Jacobian matrix or the Y admittance matrix, required in the traditional Newton Raphson and Gauss implicit Z matrix algorithms, are not necessary in the new development. Two developed matrices, the bus-injection to branch-current matrix and the branch-current to bus-voltage matrix, and a simple matrix multiplication are utilized to obtain power flow solutions. The proposed method is robust and very efficient compared to the conventional methods. Test results demonstrate the feasibility and validity of the proposed method.

A. Alsaadi and B. Gholami are with the Islamic Azad University, Kazeroon branch, Iran.

## II. UNBALANCED THREE-PHASE LINE MODEL

Fig. 1 shows a three-phase line section between bus i and j. The line parameters can be obtained by the method developed by Carson and Lewis [2]. A 4x4 matrix, which takes into account the self and mutual coupling effects of the unbalanced three-phase line.

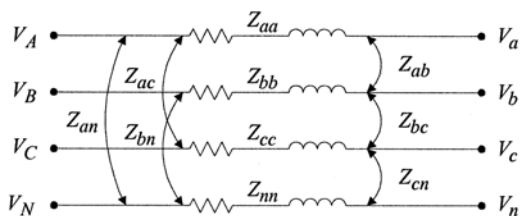

Fig. 1 Three-phase line section model

A 4x4 matrix, which takes into account the self and mutual coupling effects of the unbalanced three-phase line section, can be expressed as:

$$[Z_{abcn}] = \begin{bmatrix} Z_{aa} & Z_{ab} & Z_{ac} & Z_{an} \\ Z_{ba} & Z_{bb} & Z_{bc} & Z_{bn} \\ Z_{ca} & Z_{cb} & Z_{cc} & Z_{cn} \\ Z_{na} & Z_{nb} & Z_{nc} & Z_{nn} \end{bmatrix} \quad (1)$$

After Kron's reduction is applied, the effects of the neutral or ground wire are still included in this model as shown in (2)

$$[Z_{abc}] = \begin{bmatrix} Z_{aa-n} & Z_{ab-n} & Z_{ac-n} \\ Z_{ba-n} & Z_{bb-n} & Z_{bc-n} \\ Z_{ca-n} & Z_{cb-n} & Z_{cc-n} \end{bmatrix} \quad (2)$$

The relationship between bus voltages and branch currents in Fig. 1 can be expressed as

$$\begin{bmatrix} V_a \\ V_b \\ V_c \end{bmatrix} = \begin{bmatrix} V_A \\ V_B \\ V_C \end{bmatrix} - \begin{bmatrix} Z_{aa-n} & Z_{ab-n} & Z_{ac-n} \\ Z_{ba-n} & Z_{bb-n} & Z_{bc-n} \\ Z_{ca-n} & Z_{cb-n} & Z_{cc-n} \end{bmatrix} \begin{bmatrix} I_{Aa} \\ I_{Bb} \\ I_{Cc} \end{bmatrix} \quad (3)$$

For any phases failed to present, the corresponding row and column in this matrix will contain null-entries.

## III. ALGORITHM DEVELOPMENT

The proposed method is developed based on two derived matrices, the bus-injection to branch-current matrix and the branchcurrent to bus-voltage matrix, and equivalent current injections. In this section, the development procedure will be described in detail. For distribution networks, the equivalent-current-injection-based model is more practical [5]–[13]. For bus  $i$ , the complex load  $S_i$  is expressed by

$$S_i = P_i + jQ_i \quad i = 1 \dots N \quad (4)$$

And the corresponding equivalent current injection at the  $i$ -th iteration of solution is

$$I_i^k = I_i^r(V_i^k) + jI_i^i(V_i^k) = \left( \frac{P_i + jQ_i}{V_i^k} \right)^* \quad (5)$$

Where  $V_i^k$  and  $I_i^k$  are the bus voltage and equivalent current injection of bus at the  $k$ -th iteration, respectively.  $I_i^r$  and  $I_i^i$  are the real and imaginary parts of the equivalent current injection of bus  $i$  at the  $k$ -th iteration, respectively.

### A. Relationship Matrix Developments

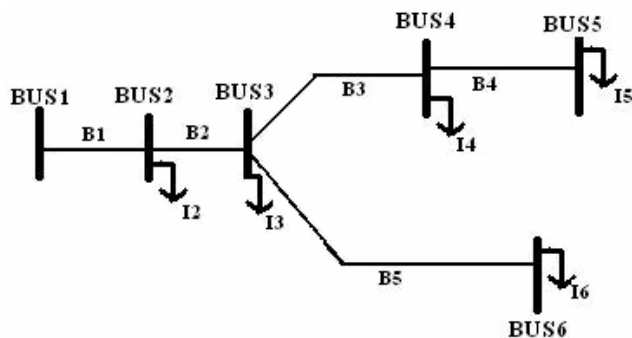

Fig. 2 Simple distribution system

A simple distribution system shown in Fig. 2 is used as an example. The power injections can be converted to the equivalent current injections by (5), and the relationship between the bus current injections and branch currents can be obtained by applying Kirchhoff's Current Law (KCL) to the distribution network. The branch currents can then be formulated as functions of equivalent current injections. For example, the branch currents  $B_1$ ,  $B_3$  and  $B_5$ , can be expressed by equivalent current injections as

$$\begin{aligned} B_1 &= I_2 + I_3 + I_4 + I_5 + I_6 \\ B_3 &= I_4 + I_5 \\ B_5 &= I_6 \end{aligned} \quad (6)$$

Therefore, the relationship between the bus current injections and branch currents can be expressed as

$$\begin{bmatrix} B_1 \\ B_2 \\ B_3 \\ B_4 \\ B_5 \end{bmatrix} = \begin{bmatrix} 1 & 1 & 1 & 1 & 1 \\ 0 & 1 & 1 & 1 & 1 \\ 0 & 0 & 1 & 1 & 0 \\ 0 & 0 & 0 & 1 & 0 \\ 0 & 0 & 0 & 0 & 1 \end{bmatrix} \begin{bmatrix} I_2 \\ I_3 \\ I_4 \\ I_5 \\ I_6 \end{bmatrix} \quad (7a)$$

Equation (7a) can be expressed in general form as:

$$[B] = [BIBC][I] \quad (7b)$$

where BIBC is the bus-injection to branch-current (BIBC) matrix.

The constant BIBC matrix is an upper triangular matrix and contains values of 0 and 1 only.

The relationship between branch currents and bus voltages as shown in Fig. 2 can be obtained by (3). For example, the voltages of bus 2, 3, and 4 are

$$V_2 = V_1 - B_1 Z_{12} \quad (8a)$$

$$V_3 = V_2 - B_2 Z_{23} \quad (8b)$$

$$V_4 = V_3 - B_3 Z_{34} \quad (8c)$$

where  $V_i$  is the voltage of bus  $i$ , and  $Z_{ij}$  is the line impedance between bus  $i$  and bus  $j$ .

Substituting (8a) and (8b) into (8c), (8c) can be rewritten as

$$V_4 = V_1 - B_1 Z_{12} - B_2 Z_{23} - B_3 Z_{34} \quad (9)$$

From (9), it can be seen that the bus voltage can be expressed as a function of branch currents, line parameters, and the substation voltage. Similar procedures can be performed on other buses; therefore, the relationship between branch currents and bus voltages can be expressed as

$$\begin{bmatrix} V_1 \\ V_1 \\ V_1 \\ V_1 \\ V_1 \end{bmatrix} - \begin{bmatrix} V_2 \\ V_3 \\ V_4 \\ V_5 \\ V_6 \end{bmatrix} = \begin{bmatrix} Z_{12} & 0 & 0 & 0 & 0 \\ Z_{12} & Z_{23} & 0 & 0 & 0 \\ Z_{12} & Z_{23} & Z_{34} & 0 & 0 \\ Z_{12} & Z_{23} & Z_{34} & Z_{45} & 0 \\ Z_{12} & Z_{23} & 0 & 0 & Z_{56} \end{bmatrix} \begin{bmatrix} B_1 \\ B_2 \\ B_3 \\ B_4 \\ B_5 \end{bmatrix} \quad (10a)$$

Equation (10a) can be rewritten in general form as:

$$[\Delta V] = [BCBV][B] \quad (10b)$$

where BCBV is the branch-current to bus-voltage (BCBV) matrix.

### B. Building Formulation Development

Observing (7), a building algorithm for BIBC matrix can be developed as follows:

Step 1) For a distribution system with  $m$ -branch section and  $n$ -bus, the dimension of the BIBC matrix is  $m \times (n-1)$ .

Step 2) If a line section ( $B_k$ ) is located between bus  $i$  and bus  $j$ , copy the column of the  $i$ -th bus of the BIBC matrix to the column of the  $j$ -th bus and fill a 1 to the position of the  $k$ -th row and the  $j$ -th bus column.

Step 3) Repeat procedure (2) until all line sections are included in the BIBC matrix. From (10), a building algorithm for BCBV matrix can be developed as follows.

Step 4) For a distribution system with  $m$ -branch section and  $n$ -bus, the dimension of the BCBV matrix is  $(n-1) \times m$ .

Step 5) If a line section is located between bus  $i$  and bus  $j$ , copy the row of the  $i$ -th bus of the BCBV matrix to the row of

the  $j$ -th bus and fill the line impedance ( $Z_{ij}$ ) to the position of the  $j$ -th bus row and the  $k$ -th column.

Step 6) Repeat procedure (5) until all line sections are included in the BCBV matrix.

The algorithm can easily be expanded to a multiphase line section or bus. For example, if the line section between bus and bus is a three-phase line section, the corresponding branch current  $B_i$  will be a  $3 \times 1$  vector and the in the BIBC matrix will be a  $3 \times 3$  identity matrix. Similarly, if the line section between bus  $i$  and bus  $j$  is a three-phase line section, the  $Z_{ij}$  in the BCBV matrix is a  $3 \times 3$  impedance matrix as shown in (2).

It can also be seen that the building algorithms of the BIBC and BCBV matrices are similar. In fact, these two matrices were built in the same subroutine of our test program. Therefore, the computation resources needed can be saved. In addition, the building algorithms are developed based on the traditional bus-branch oriented database; thus, the data preparation time can be reduced and the proposed method can be easily integrated into the existent DA.

### C. Solution Technique Developments

The BIBC and BCBV matrices are developed based on the topological structure of distribution systems. The BIBC matrix represents the relationship between bus current injections and branch currents. The corresponding variations at branch currents, generated by the variations at bus current injections, can be calculated directly by the BIBC matrix. The BCBV matrix represents the relationship between branch currents and bus voltages. The corresponding variations at bus voltages, generated by the variations at branch currents, can be calculated directly by the BCBV matrix. Combining (7b) and (10b), the relationship between bus current injections and bus voltages can be expressed as

$$[\Delta V] = [BCBV][BIBC][I] = [DLF][I] \quad (11)$$

And the solution for distribution power flow can be obtained by solving (12) iteratively

$$I_i^k = I_i^r(V_i^k) + jI_i^i(V_i^k) = \left( \frac{P_i + jQ_i}{V_i^k} \right)^* \quad (12a)$$

$$[\Delta V^{k+1}] = [DLF][I^k] \quad (12b)$$

$$[V^{k+1}] = [V^0] + [\Delta V^{k+1}] \quad (12c)$$

According to the research, the arithmetic operation number of LU factorization is approximately proportional to  $N^3$ . For a large value of  $N$ , the LU factorization will occupy a large portion of the computational time. Therefore, if the LU factorization can be avoided, the power flow method can save tremendous computational resource. From the solution techniques described before, the LU decomposition and forward/backward substitution of the Jacobian matrix or the  $Y$  admittance matrix are no longer necessary for the proposed method. Only the **DLF matrix** is necessary in solving power flow problem. Therefore, the proposed method can save considerable computation resources and this feature makes the proposed method suitable for online operation.

## V. TEST RESULTS

The proposed three-phase power flow algorithm was implemented using MATLAB. Two methods are used for tests and the convergence tolerance is set at 0.001 p.u.

Method 1: The forward/backward method [10].

Method 2: The proposed algorithm.

### A. Accuracy Comparison

For any new method, it is important to make sure that the final solution of the new method is the same as the existent method. An eight-bus system

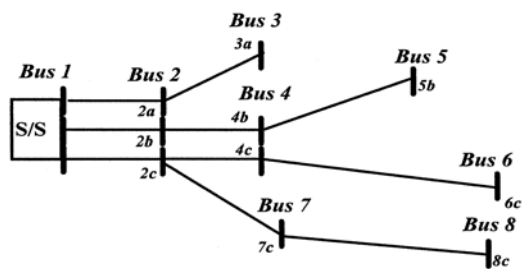

Fig. 4 Eight-bus distribution system

TABLE I  
 FINAL CONVERGED VOLTAGE SOLUTIONS

Bus Number	Method 1		Method 2		Phase
	V (pu)	Ang. (Rad.)	V (pu)	Ang. (Rad.)	
1	1.0000	0.0000	1.0000	0.0000	A
1	1.0000	-2.0944	1.0000	-2.0944	B
1	1.0000	2.0944	1.0000	2.0944	C
2	0.9840	0.0032	0.9839	0.0032	A
2	0.9714	-2.0902	0.9712	-2.0902	B
2	0.9699	2.0939	0.9697	2.0939	C
3	0.9833	0.0031	0.9832	0.0031	A
4	0.9653	-2.0897	0.9652	-2.0897	B
4	0.9672	2.0932	0.9669	2.0932	C
5	0.9644	-2.0898	0.9640	-2.0898	B
6	0.9652	2.0930	0.9650	2.0930	C
7	0.9686	2.0937	0.9683	2.0937	C
8	0.9674	2.0936	0.9671	2.0936	C

TABLE II  
 TEST FEEDER

Feeder No.	No. of Nodes	Length
1	45	1.5 km
2	90	2.5 km
3	135	3.2 km
4	180	4.0 km
5	270	7.4 km

TABLE III  
 NUMBER OF ITERATION AND NORMALIZED EXECUTION TIME

Feeder No.	Method 1		Method 2	
	NET	IT	NET	IT
1	2.6229	3	1.0000	3
2	14.426	3	2.1639	3
3	52.131	4	5.4098	4
4	131.15	4	9.0164	4
5	432.79	4	18.033	4

(1) NET means the Normalized Execution Time.

(2) IT means the Number of Iteration.

(3) Performance 1.0 is set in Method 2 for Feeder 1.

(equivalent 13-node system), including the three-phase, double-phase, and single-phase line sections and buses as shown in Fig. 4 is used for comparisons. The final voltage solutions of method 1 and method 2 are shown in Table I. From Table I, the final converged voltage solutions of method 2 are very close to the solution of method 1. It means that the accuracy of the proposed method is almost the same as the commonly used forward/backward method.

### B. Performance Test

A main feeder trunk with 3x90-phase buses, is used for this test. The single and double-phase laterals have been lumped to form the unbalanced loads for testing purposes. This trunk is then chopped into various sizes for tests as shown in Table II. The substation is modeled as the slack bus.

Table III lists the number of iterations and the normalized execution time for both methods. It can be seen that method 2 is more efficient, especially when the network size increases, since the time-consuming processes such as LU factorization and forward/backward substitution of admittance matrix are not necessary for method 2. For a 270-node system, method 2 is almost 24 times faster than method 1.

### C. Robustness Test

One of the major reasons, which make the power flow program diverge, is the ill-condition problem of the Jacobian matrix or admittance matrix. It usually occurs when the system contains some very short lines or very long lines. In order to prove that the proposed method can be utilized in severe conditions, IEEE 37-bus test feeder is used [14]. The test feeder is adjusted by changing the length of eight line sections. Four of them are multiplied by ten, and the other four are divided by ten. The test result shows the number of iterations for this case is 4 and the execution time is 0.0181 s. It means that the proposed method is robust and very suitable for online use.

## VI. DISCUSSION AND CONCLUSION

In this paper, a direct approach for distribution power flow solution was proposed. Two matrices, which are developed from the topological characteristics of distribution systems, are used to solve power flow problem. The BIBC matrix represents the relationship between bus current injections and branch currents, and the BCBV matrix represents the relationship between branch currents and bus voltages. These two matrices are combined to form a direct approach for solving power flow problems. The time-consuming procedures, such as forward/backward substitution of the Jacobian matrix or admittance matrix, are not necessary in the proposed method. The ill-conditioned problem that usually occurs during the other traditional methods will not occur in the proposed solution techniques. Therefore, the proposed method is both robust and efficient. Test results show that the proposed method is suitable for large-scale distribution systems.

REFERENCES

- [1] IEEE Tutorial Course on Distribution Automation.
- [2] IEEE Tutorial Course on Power Distribution Planning.
- [3] W. M. Lin and M. S. Chen, "An overall distribution automation structure," *Elect. Power Syst. Res.*, vol. 10, pp. 7–19, 1986.
- [4] B. Stott and O. Alsac, "Fast decoupled load flow," *IEEE Trans. Power Appar. Syst.*, vol. 93, pp. 859–869, May/June 1974.
- [5] J. H. Teng and W. M. Lin, "Current-based power flowsolutions for distribution systems," in *Proc. IEEE Int. Conf. Power Syst. Technol.*, Beijing, China, 1994, pp. 414–418.
- [6] T. S. Chen, M. S. Chen, T. Inoue, and E. A. Chebli, "Three-phase cogenerator and transformer models for distribution system analysis," *IEEE Trans. Power Delivery*, vol. 6, pp. 1671–1681.2, Oct. 1991.
- [7] T.-H. Chen, M.-S. Chen, K.-J. Hwang, P. Kotas, and E. A. Chebli, "Distribution system power flow analysis—A rigid approach," *IEEE Trans. Power Delivery*, vol. 6, pp. 1146–1152, July 1991.
- [8] T. H. Chen and J. D. Chang, "Open wye-open delta and open delta-open delta transformer models for rigorous distribution system analysis," in *Proc. Inst. Elect. Eng.*, vol. 139, 1992, pp. 227–234.
- [9] K. A. Birt, J. J. Graffy, J. D. McDonald, and A. H. El-Abiad, "Three phase load flow program," *IEEE Trans. Power Appar. Syst.*, vol. PAS-95, pp. 59–65, Jan./Feb. 1976.
- [10] D. Shirmohammadi, H. W. Hong, A. Semlyen, and G. X. Luo, "A compensation- based power flow method for weakly meshed distribution and transmission networks," *IEEE Trans. Power Syst.*, vol. 3, pp. 753–762, May 1988.
- [11] G. X. Luo and A. Semlyen, "Efficient load flow for large weakly meshed networks," *IEEE Trans. Power Syst.*, vol. 5, pp. 1309–1316, Nov. 1990.
- [12] C. S. Cheng and D. Shirmohammadi, "A three-phase power flowmethod for real-time distribution system analysis," *IEEE Trans. Power Syst.*, vol. 10, pp. 671–679, May 1995.
- [13] R. D. Zimmerman and H. D. Chiang, "Fast decoupled power flow for unbalanced radial distribution systems," *IEEE Trans. Power Syst.*, vol. 10, pp. 2045–2052, Nov. 1995.
- [14] W. M. Kersting and L. Willis, "Radial Distribution Test Systems, IEEE Trans. Power Syst.", vol. 6, IEEE Distribution Planning Working Group Rep., Aug. 1991.