

Capacity Enhancement in Wireless Networks using Directional Antennas

Sedat Atmaca, Celal Ceken, and Ismail Erturk

Abstract—One of the biggest drawbacks of the wireless environment is the limited bandwidth. However, the users sharing this limited bandwidth have been increasing considerably. SDMA technique which entails using directional antennas allows to increase the capacity of a wireless network by separating users in the medium. In this paper, it has been presented how the capacity can be enhanced while the mean delay is reduced by using directional antennas in wireless networks employing TDMA/FDD MAC. Computer modeling and simulation of the wireless system studied are realized using OPNET Modeler. Preliminary simulation results are presented and the performance of the model using directional antennas is evaluated and compared consistently with the one using omnidirectional antennas.

Keywords— Directional Antenna, TDMA, SDMA,

I. INTRODUCTION

TOGETHER with the developments in high performance wireless computers and other mobile devices, the importance of wireless/mobile data communication has been increasing and there has been a growing demand for using wireless medium. As the number of users is increased, the need for capacity is increased as well.

Capacity and performance of wireless communication systems are usually limited by such effects as multipath and co-channel interference. Multipath is a condition which arises when a transmitted signal undergoes reflection from various obstacles in the propagation environment. This gives rise to multipath signals arriving from different directions. Since the multipath signals follow different paths, they have different phases when they arrive at the receiver. The result is degradation in signal quality when they are combined at the receiver due to the phase mismatch. Co-channel interference is the interference between two signals that operate at the same frequency. In cellular communication the interference is usually caused by a signal from a different cell occupying the same frequency band [1, 2].

Directional antennas generally known as smart antennas are one of the most promising technologies that will enable a higher capacity in wireless networks by effectively reducing multipath and co-channel interference. This is achieved by focusing the radiation only in the desired direction. Smart

antennas employ a set of radiating elements arranged in the form of an array. The signals from these elements are combined to form a movable or switchable beam pattern that follows the desired user. In a smart antenna system the arrays by themselves are not smart, it is the digital signal processing that makes them smart. The process of combining the signals and the focusing the radiation in particular direction is often referred to as digital beamforming [3].

The goal of the using directional antennas in wireless medium is to maximize the performance of the wireless networks by increasing capacity, range and Signal-to-Interference-Plus-Noise Ratio (SNR). Directional antennas provide an increased radiated power due to focusing the transmitter power on one direction. This improves the range of the transmitter. On the other hand, the directivity of the antenna allows the node to cancel interfering signals arriving at the receiver from other directions [3]. The antennas work reciprocal, and for this reason, the received power at the receiver is also increased.

In this study presented, to improve the system capacity TDMA (Time Division Multiple Access) is employed together with SDMA (Space Division Multiple Access) technique. In a TDMA wireless system, the transmission time (frame) is divided into time slots assigned to the Wireless Terminals (WTs) and several users share the same frequency channel simultaneously in their own slots to communicate. In an SDMA system, the BS does not transmit the signal throughout the space. It concentrates power in the direction of the mobile unit [2]. This reduces the power in the directions where other terminals are present. The same principle can be applied for reception. In order to define directional antenna pattern OPNET Antenna Pattern Editor is used.

The rest of paper is organized as follows. In section II, we explain the directional antennas and their types. Section III presents the proposed simulation model and explains BS Model and WT model respectively. Section IV presents the simulation results with comparisons followed by final remarks in Section V.

II. SMART ANTENNA OVERVIEW

Recently, the need for providing high quality wireless access and the great demand on high speed wireless links have increased dramatically. Consequently researchers have been motivated to enhance the wireless network capacity to meet the demand for subscriber growth.

Directional antennas, when used appropriately in mobile communications, offer significant benefits in system

Manuscript received April 20, 2006.

Authors are with Technical Education Faculty, Electronics and Computer Education Department, Kocaeli University, 41380 Kocaeli, Turkey (e-mail: sedatatmaca@kou.edu.tr, cceken@kou.edu.tr, erturk@kou.edu.tr).

performance by increasing channel capacity and spectrum efficiency. They also reduce multipath and increase range coverage. These antennas communicate directionally by forming specific antenna-beam patterns [4,5]. They direct their main beam, with increased gain, in the direction of the user, and while directing nulls in directions away from the main beam.

The gain and the beam width of an antenna are important concepts. Gain is used to quantify the directionality of an antenna and generally describes the relative power in one direction compared to an omni directional antenna. Beam width is the angle between the half-power (-3 dB) points of the main lobe, when referenced to the peak effective radiated power of the main beam [6]. Gain and beam width are related to each other as basically, the more directional the antenna is, the higher the antenna gain and the smaller the beam width are (Fig. 1).

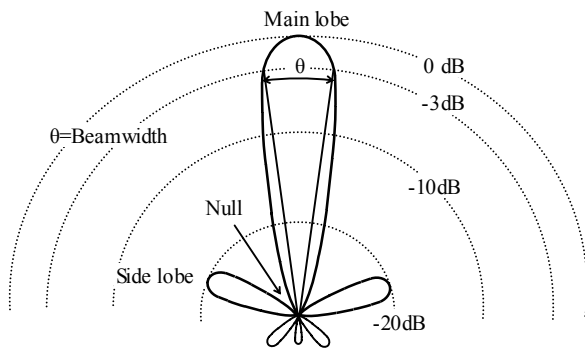
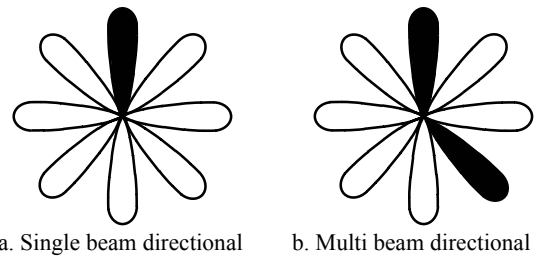

Fig. 1 Beamwidth

There are several techniques of implementing smart antennas. Basically, they are described in two categories: switched beam systems and adaptive array systems. The switched beam antenna system has a switching mechanism enabling it to select and then switch the right beam which gives the best directivity and gain to the node under consideration (Fig. 2). This technique does not steer or scan the beam in the direction of the desired signal. Switched beam systems can be divided into groups: single beam and multi beam directional antennas. In single beam directional antennas, only one beam is active at a given time. Simultaneous transmissions are not allowed because in this system there is only one transceiver. On the other hand, multiple beam directional antenna system is an example of Space Division Multiple Access (SDMA) system. Here, each directional antenna can be used and transmissions are allowed at the same time and frequency. The number of beams is equal to the number of transceivers [2].



a. Single beam directional b. Multi beam directional

Fig. 2 Switched beam directional antenna

The adaptive array system tracks the mobile user continuously by steering the main beam towards the user and at the same time forming nulls in the directions of the interfering signal. This antenna system is out of the scope of the works carried out and presented here, and therefore not explained in detail.

III. PROPOSED SYSTEM MODEL

TDMA is a multiple access technology that allows several users to share a single radio frequency channel by allocating unique time slots to each user in each channel. It divides a total band into several time slots. Each active user is assigned one or more slots for transmission of its data traffic. Users are identified with the slot numbers that have been assigned to them, so they know how much to wait within the TDMA before starting transmission.

SDMA is a wireless medium access technique that divides the environment into smaller spaces where the users are located with a sufficient angular separation and enables mobile users to have access to the communication channel based on their position information in space. It provides both optimized use of frequency spectrum and enhanced capacity of a wireless system.

In this study we have integrated TDMA system with SDMA, called SDMA/TDMA/FDD. It utilizes the radio spectrum more efficiently compared to classical TDMA approach. This is done by allowing more than one WTs to use the same time slot.

In this work, a TDMA/FDD MAC scheme with SDMA is employed to increase wireless medium capacity. TDMA is preferred due to its superiority and suitability for real-time multimedia traffics. In the system modeled, radio spectrum is divided into time slots which are assigned to each user to send data only in its own dedicated slots. The wireless medium is also divided in two spaces. Thus, within the different space every wireless node can use the same time slot to transmit data to the BS. Due to the FDD duplexing technique utilized in the system MAC, two distinct carrier frequencies are used for the uplink and downlink channels.

In our proposed model, the BS uses directional antennas for both uplink and downlink directions. For uplink, it uses two individual receiver and antennas attached to them. It has 180° bandwidth which enables to cover 360° by two antennas, meaning that the space is divided into two equal subspaces. The BS monitors the signal levels on two beams and chooses

the better one. The better beam is defined as the beam over which the BS gets a signal with maximum SNR [7].

For downlink, the BS uses two individual transmitter and antennas attached to them. It has 180° bandwidth which enables to cover 360° by two antennas. In order to use the SDMA in MAC protocol, the BS must know the location of each user. After receiving packet, the BS learns the destination user because the proposed packet format contains destination address, and then it uses the suitable beam covering the destination area and transmits packets towards the user. Thus transmission takes place successfully.

The simulation system has been developed using Optimum Network Simulation Tool (OPNET Modeler). OPNET simulations are event-driven. The wireless communication channel is modeled by 13 pipeline stages including antenna gains, propagation delay, signal-to-noise ratio, calculation of background noise and interface noise transmission delay, etc. OPNET also supports directional communications and this feature allows for a very realistic modeling of directional radio communications.

The proposed model is divided into two main complementary parts operating at the WTs and the BS. The following sub-sections explain in detail all functions in both parts together with their translation into the simulation environment in the OPNET Modeler.

A. Base Station Model

In Fig. 3-a, the node model of the BS is shown. The BS model is composed of a MAC module and an Antenna Controller module. It has two directional antennas for receiving and two directional antennas for transmitting. The main function of the MAC module in the BS model is to receive packets from receivers and to transmit them to the Antenna Controller module. The Antenna Controller directs its main beam for both receiving and transmitting antennas. In this work it is assumed that Antenna Controller knows the number of terminals and the position information of them in the space. For receiving, as the Antenna Controller knows the terminals position information, it directs its main beam towards them. Thus, the packets coming from the pointed node are sent to the MAC, other packets with low SNR are eliminated by the Antenna Controller. For transmitting, the Antenna Controller extracts the destination address from the packet and decides which antenna beam is used, and knowing their position information in the space it directs the main beam towards the particular user.

In Fig. 3-b, the process model of the BS Antenna Controller is illustrated. ANT1 state machine gets data packets from WT1 to which AntRx1 beam has been directed. ANT2 state machine gets data packets from WT2 to which AntRx2 beam has been directed. MAC_OUT process model sends data to the MAC.

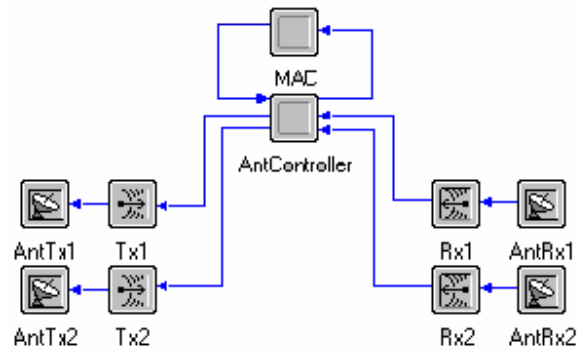

Fig. 3 a) BS node model

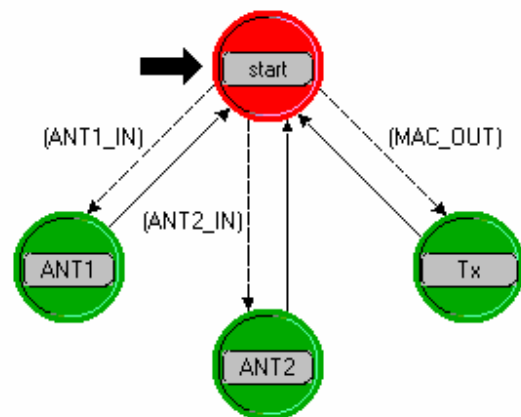

Fig. 3 b) BS Antenna Controller process model

B. Wireless Terminal Model

The WT functions of the proposed model include two main processes. These are namely getting its own time slots from the BS and sending data in the allocated time slots.

WT node model designed using OPNET Modeler is shown in Fig. 4-a. The Source module used in the WT is responsible for packet generation according to the packet size and arrival time parameters defined. The Sink module collects statistics of the arrived packets and then destroys them.

In Fig. 4-b the process model of the MAC module used in WT node model is illustrated. The Transmit process module is used to send data in an appropriate slot time and the Receive process model is used to receive data from the BS.

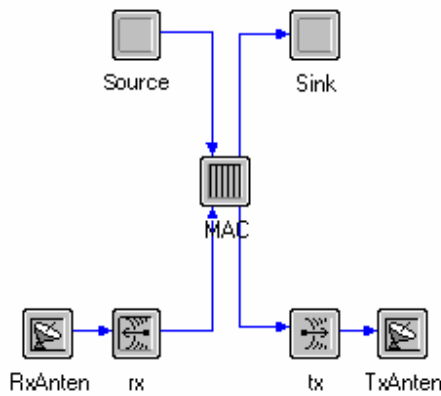

Fig. 4 a) Wireless Terminal node model

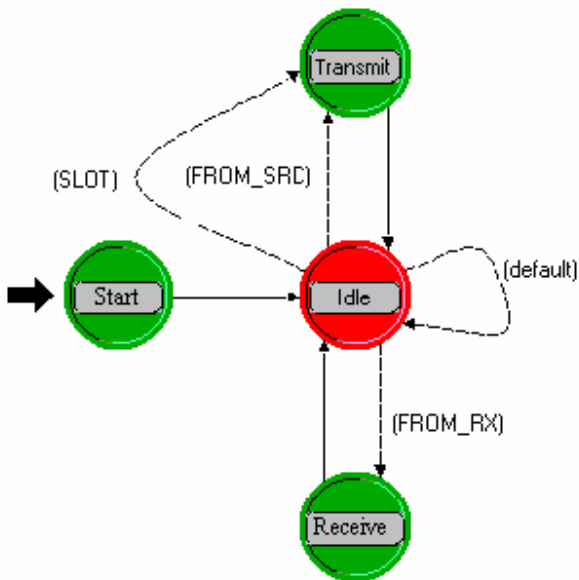

Fig.4 b) Wireless Terminal MAC process model

The packet format used by WTs is given in Fig. 5. Proposed MAC packets comprise 432 bits, consisting of a 16-bit source address, a 16-bit destination address and 400-bit payload.

Source Address (16-bit)	Destination Address (16-bit)
PAYLOAD (400-bit)	

Fig. 5 Proposed MAC Protocol Packet Structure

C. Directional Antenna Model

To define the antenna patterns employed, OPNET antenna pattern editor has been utilised. The antenna pattern can be associated with a radio transmitter and/or receiver to provide the gain defined by the pattern using an antenna module in the node editor. This module provides an attribute called “pattern” that allows for the specification of the pattern.

IV. COMPUTER SIMULATION AND PERFORMANCE ANALYSIS OF THE PROPOSED MODEL

The WTs in the basic example scenario implemented using OPNET Modeler (Fig. 6) employ the proposed SDMA based TDMA/FDD MAC protocol explained in the previous section. Diameter of the cell which constructs the network topology is chosen 100 meters.

In the example scenario, there are four WTs which are placed in two different areas in the space and one BS with four directional antennas. Two of the WTs are placed in the first area, and the others are placed in the second area. In this way, wireless medium is divided into two individual spaces. The BS has two different directional antennas both for receiving and transmitting, and each has predefined fixed beams covering 180° in the medium. For receiving, each BS receiver is directed to cover half of the entire area. The SNR of the received packets is monitored by the Antenna Controller module. While the packets whose SNR values exceed the predefined threshold value are sent to the MAC, other packets are destroyed in the antenna module. Similarly, each BS transmitter directed to its individual space has predefined fixed beams. After receiving packets from the MAC module, Antenna Controller extracts the destination address from them and decides which antenna beam is used, and then sends these packets towards the destination WT.

The data traffic introduced to the network by WT1 and WT2 are destined to WT3 and WT4, respectively.

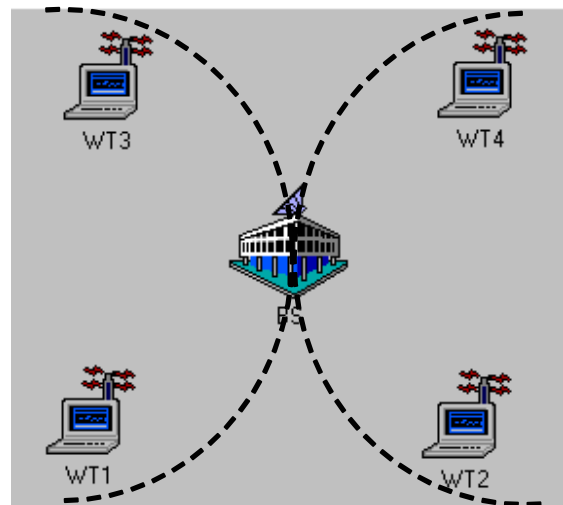

Fig. 6 Example wireless network scenario

Another wireless network model that is analogous to the one explained above except that omnidirectional antenna pattern is utilized instead of directional one is also simulated using OPNET Modeler for consistent performance comparisons. Working conditions of both models are chosen to be same.

A. Simulation Results

Preliminary simulation results of the both wireless network models described above are presented under varying network

load conditions followed by performance comparisons and analysis.

In the simulation environment a free space channel propagation model that supports to predict received signal strength when the transmitter and receiver have a clear, unobstructed line-of-sight path between them is utilized. To avoid the transient effects the simulation statistics are flushed after approximately 10 seconds. The simulation parameters used are given in Table I.

TABLE I
 SIMULATION PARAMETERS

Traffic Sources	30,000–100,000*(Bytes/s)
Uplink/Downlink Bit Rate	25 Mb/s
Frequency Band	Uplink=3 GHz and Downlink=4 GHz
Transmitter Power	BS= 100 mW and WTs=100 mW
Modulation	QPSK
Channel Model	Free Space Propagation Model (LoS)
*Generated using Exponential Distribution Function $Exp(\text{Mean})$.	

The performance metrics concerned in this work are average packet transfer delay, which also reflect the system utilization effect on different application traffics, and SNR. The cell loss ratio metric is not considered here as the buffers employed in the simulation models are assumed to have enough capacity so that no data cell is lost due to buffer overflow.

For both wireless network models, a slot length of 200 μ seconds which has been determined considering 25 Mb/s data rate is chosen. With a total number of two slots/frame, each time slot contains 1 data packet described in Fig. 5.

Varying the message size of all WT application traffics, average end-to-end delay (EED) and SNR results of the data traffic transfer between WT1 and WT3, have been collected during the simulation run time for both wireless network models.

In Fig. 7, average EED results of the data traffic between WT1 and WT3 in wireless network model with directional antenna and those of with omni-directional antenna are presented. As seen from the figure, EED results for both models are approximately the same. In addition, the more the load introduced to the network is increased, the higher the EED delay that the WTs experience.

Normally, it is expected that EED results of the model with directional antenna would be less than those of with omnidirectional under same network conditions. However, as a free space channel propagation model, enabling prediction of received signal strength when the transmitter and receiver have a clear, unobstructed line-of-sight path between them, has been utilized, the mean delay values obtained are approximately the similar.

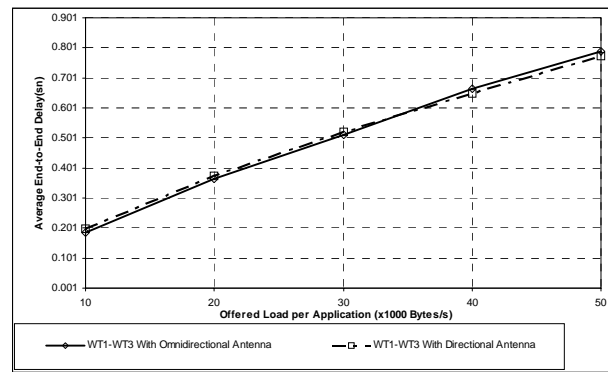

Fig. 7 WT1–WT3 Average EED results for the wireless network models

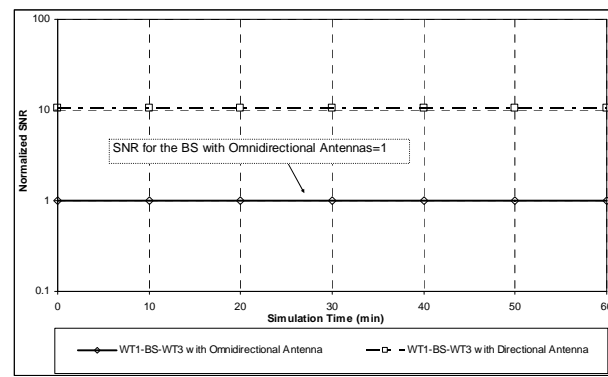

Fig. 8 Normalized SNR results for the wireless network utilising directional antenna

Fig. 8 shows the SNR results for the data traffic between Wt1-BS-WT3 in the wireless network model for the BS with both the directional and omni-directional antennas. As it is seen from the graphs, the SNR values of the former model with directional antenna is approximately 10 times better than those of the latter.

Besides, as a result of separating the space into 2 different areas using directional antenna, the user capacity has been enhanced twice, resulting in two users in different spaces have been allocated to the same time slot simultaneously.

V. CONCLUSION

In this research study presented, mainly it is aimed to enhance the user capacity of a wireless network employing a TDMA/FDD based MAC protocol. In this context, a new wireless network model with directional antennas has been developed and its design stages have been presented.

An example wireless network scenario with WTs equipped with directional antennas has been modeled using OPNET Modeler and simulated under varying traffic load conditions. The simulation results are presented together with comparisons those of an omni-directional counterpart. According to the simulation results obtained the SNR values of the proposed wireless model with directional antennas are

better than those of wireless model with omni-directional antennas. Besides, the capacity of wireless medium is also enhanced as a consequence of directional antennas employed in the BS.

REFERENCES

- [1] T.S. Rappaport, *Wireless Communications, Principles and Practice*. Englewood Cliffs, Prentice Hall, 1996.
- [2] J.C. Liberti, T.S. Rappaport; "Smart Antennas for Wireless Communications: IS-95 and Third Generation CDMA Applications". Prentice Hall, Upper Saddle River, 1999.
- [3] E. Ulukan, *Wireless LANS with Smart Antennas*, M.Sc Thesis, University of Sabanci, Turkey, 2005.
- [4] M. Chryssomallis, "Smart Antennas", *IEEE Antennas and Propagation Magazine*, Vol. 2, No 3, June 2000, pp.129-136.
- [5] Lehne, Per H.; Pettersen, Magne; "An overview of smart antenna technology for mobile communications systems", *IEEE Communications Surveys*, Fourth Quarter 1999, Vol.2, No.4.
- [6] R. Ramanathan, "On the performance of ad hoc networks using beamforming antennas", *Proc. ACM MobiHoc 2001*, Long Beach, California, USA, October 2001.
- [7] Ulukan, E., Gurbuz, O., "Using Switched Beam Smart Antennas in Wireless Ad Hoc Networks with Angular MAC Protocol", *The Third Annual Mediterranean Ad Hoc Networking Workshop, MEDHOCNET 2004*, June 27-30, 2004.

Sedat Atmaca received the M.Sc. degree from Sakarya University, Turkey in 2002 and he is currently working toward the Ph.D. degree in Kocaeli University, Turkey. His active research interests include smart antennas, wireless data communications, WLAN.

Celal Ceken received the M.Sc. and Ph.D. degrees from Kocaeli University, Turkey in 2001 and 2004, respectively. His active research interests include wireless communications, broadband networks, ATM networks, and high speed communication protocols.

Ismail Erturk received the M.Sc. and Ph.D. degrees from Sussex University, UK in 1996 and 2000, respectively. His research interests are ATM, wireless data communications, CAN, LANs/WANs, IP and QoS, MPLS and real-time multimedia applications.