

Investigation on Adjustable Mirror bender Using Light beam Size

A. Oonsivilai, A. Suthummapiwat, and P.Songsiritthigul

Abstract—In this research, the use of light beam size to design the adjustable mirror bender is presented. The focused beam line characterized by its size towards the synchrotron light beam line is investigated. The COSMOSWorks is used in all simulation components of curvature adjustment system to analyze in finite element method. The results based on simulation covers the use of applied forces during adjustment of the mirror radius are presented.

Keywords—light beam-line, mirror bender, synchrotron light machine.

I. INTRODUCTION

THE new developments and advances in science and technology have been experienced in the few past decades. The applications of these new inventions are found in many systems. One of these applications is the synchrotron light machine.

The Synchrotron light is the electromagnetic radiation emitted when electrons, moving at velocities close to the speed of light, are forced to change direction under the action of a magnetic field. The synchrotron light is unique in its intensity and brilliance and it can be generated across the range of the electromagnetic spectrum: from infrared to x-rays. Applications of synchrotron light are used in many aspects such as physical science, biological physics and so forth. The synchrotron light machine is composed of many important parts including the beam line system. This system comprises many parts such as vacuum tube, vacuum chamber and especially, optical equipments. The optical equipments are mirror grating and crystal etc. functioning to select wavelength, size and focusing of beam light that point at study sample. One of the important techniques in synchrotron applications is X-PEEM (X-ray Photoemission Electron Microscopy) applying in nano-structure spectroscopy and

even in taking photo in micro-nano scale. The principle of X-PEEM is to use suitable soft X-rays or vacuum ultraviolet range to excite electron in atom of sample emitted from sample for studying its photoelectron. Photoelectron energy depends on energy levels of atom, type of atom and wavelength of exciting x-rays. Photoelectrons having diameters about 2-100 microns are emitted collected and amplified by equipments that similar to use in SEM (scanning electron microscopy). Amplified electron is brought to image on screen as shown in figure 1 that able to measure in chemical analysis of minute area (<100 nanometer) . Intensity or contrast of picture that images on screen is the characteristics of surface, type of atom, work function of material and/or characteristic of magnetic domain.

New beam-line system has been constructing in Siam Photon lab at SLRI (Synchrotron Light Research Institute). It will use synchrotron light produced from an undulator machine to apply for X-PEEM technique and PES (Photoemission spectroscopy) [1]. Optical equipments of the beamline shown in figure 2 consist of a mirror TO to focus synchrotron light into S1 of monochromator. Part of the monochromator is to start at inlet S1 to outlet S2. Behind monochromator, light is able to use either X-PEEM or PES technique by moving in and out of M2C_y mirror. This work points at focusing system of X-PEEM technique for focusing synchrotron light on sample in microscale and keeping most part of light is in right position of X-PEEM microscope for high performance.

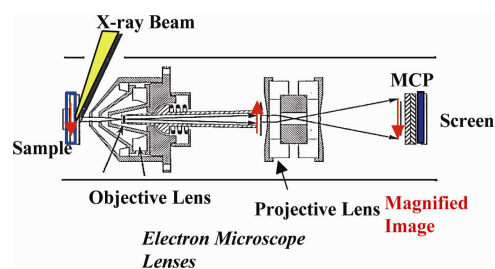

Fig. 1 Diagram of PEEM at BL7.3.2 of Advanced Light.

Focusing system behind monochromator is composed of M2V and M2H mirrors that have cylinder surface to focus light in vertical and horizontal, respectively. M2H has constant radius on surface so that size of beam on sample is about 150 microns. On the other hand, M2V is able to adjust curvature radius value for selecting the beam size in vertical. Required curvature radius is in between 50,000mm to 60,000mm.

A. Oonsivilai is with Smart Materials and Intelligent System and Alternative and Sustainable Energy Research Unit, School of Electrical Engineering, Institute of Engineering, Suranaree University of Technology 111 University Avenue, Muang District, Nakhon Ratchasima, Thailand 30000 (corresponding author to provide phone: +66 (0)815-48-7728; fax: +66(0) 44-21-7047; e-mail: anant@ sut.ac.th).

A. Suthummapiwat is with School of Mechatronics Engineering, Institute of Engineering, Suranaree University of Technology 111 University Avenue, Muang District, Nakhon Ratchasima, Thailand 30000 (e-mail: Apirak_sut@ slri.or.th).

P. Songsiritthigul is with Synchrotron Light Research Institute (Public Organization). 111 University Avenue, Muang District, Nakhon Ratchasima, Thailand 30000 (e-mail: Prayoon@ slri.or.th).

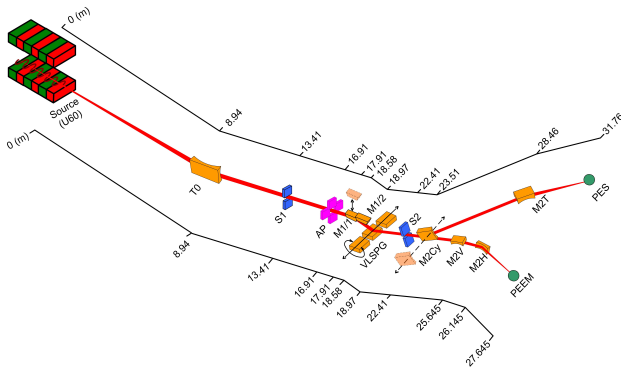

Fig. 2 Diagram of optical alignment of BL3 [1]

Therefore, all parts of light are on FOV (Field of view) of microscope XPEEM (2-150 microns). This technique is relative to beam size hitting to sample and amplified system of microscopy technique. Beam adjustment is significant so that mirror bender system is needed and used to change the focus of beam position on sample as shown in figure 3. Hence, beam adjustment on sample is worked by changing curvature radius of mirror related to FOV of X-PEEM.

The relation between the entrance armlength (r , or the source distance), the exit armlength (r' , or the image distance), the angle of incidence (α) and the radius of curvature of cylindrical surface (R) is given by the Equation 1

$$\frac{\cos^2 \alpha}{r} + \frac{\cos^2 \alpha}{r'} = \frac{2 \cos \alpha}{R} \quad (1)$$

Figure 3 shows that the smallest beam occurs when curvature radius of mirror is forced to focus beam in as same position as sample. Beam size is able to adjust by changing focusing point at before or behind sample. In general, mirror base for beam focusing in UV range is made from Zerodur or Silicon coated metallic thin film that is good in reflection such as gold or nickel. For M2V mirror will be built from Zerodur material which is mixed between glass and ceramic and has nearly zero thermal expansion ($\pm 0.15 \times 10^{-6} / ^\circ\text{C}$) at room temperature.

Beam adjustment for minute size is complex and difficult for giving precise moment or accuracy force [2] that this is an important thing and interesting to design and build the mechanical movement in the first time in our country.

II. DESIGN OF TWO-ARM MIRROR BENDER SYSTEM

To design and develop two-arm mirror bender that SolidWorks program is used to design each part of its structure. When the whole parts are constructed, its system is tested and simulated by relative equation between force and changing curvature radius of mirror. By simulation, the mirror is Al Alloy(6061) compared to Zerodur material. Cosmos program combined with SolidWorks is used for finite element method and simulation of force to act on the system.

from the simulation obtain and analyze for building a real system.

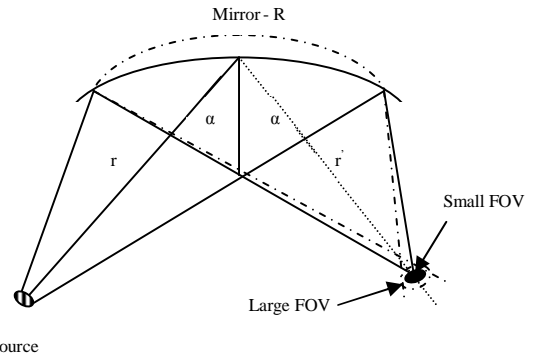

Fig. 3 Beam adjustment on sample by changing curvature radius of mirror

A. Theory and calculation

General equation for the moment at end of both sides of a mirror is set catch confiscated $M_1 = hF_1$ and $M_2 = hF_2$. The adjustment of the radius of curvature of a mirror bender can accurately be analyzed using the theorem of beam [3]. Changing the shape of the beam under the moments M_1 and M_2 , as shown in figure 4, can be explained by the differential equation given in Equation 2 for visual effects [4].

$$\frac{d^2 z}{dx^2} = \left(\frac{h}{EI} \right) \left[\frac{F_1 + F_2}{2} + \left(\frac{F_2 - F_1}{L} \right) x \right] \quad (2)$$

where E is the young modulus, h is the distance between perpendicular force and the ration center of the beam. $I = t^3(w/12)$ is the moment of inertia, where t is the thickness, w is the width and L is the length of mirror, z is the distance along axis of curve change and x is the length along axis of mirror.

Changing the radius of curvature of the mirror can obtained from the equation $R \approx 1/(d^2 z/dx^2) \approx EI/hF$. In taking the moment between both systems allows the nucleus to change or spindle unlike. Therefore, a constant factor must be added into equation. The value of the bending loss factor is a constant which depends on the system design [5], available only from experiments. Therefore, equation 2 will be modified by multiplying the loss bending-factor.

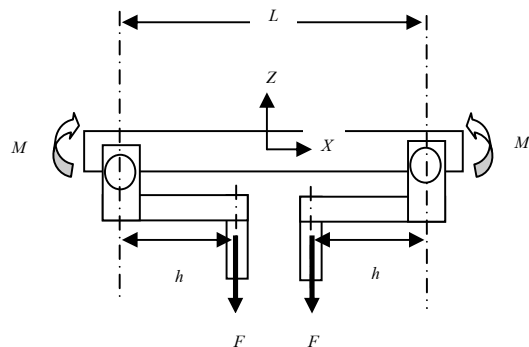

Fig. 4 Diagram of structure of mirror bender system

B. Mechanical design

This research concentrates to two-arm curvature adjustment for a prototype having dimension of 320mm x 160mm x 134mm. All components are made in the country. The advantage of the two-arm curvature adjustment is based on the ability to apply force freely in centric system. Software that assists in design the system is Solidworks. Structures of the two-arm curvature adjustment are shown in figure 5. The curvature adjustment of the system counts on taking moment at edge of both sides of arm [6].

Most of structures are made in machine shop at Synchrotron Light Research Institute (Public organization) since it is easy to change, add and develop all of components further. Figure 6 and table I show details and all of components of the system.

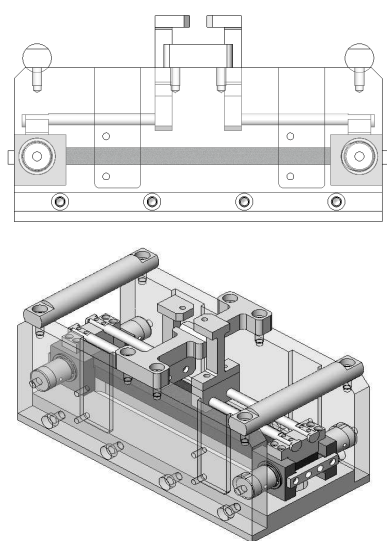

Fig. 5 Structure model of mechanism two-arm bender design.

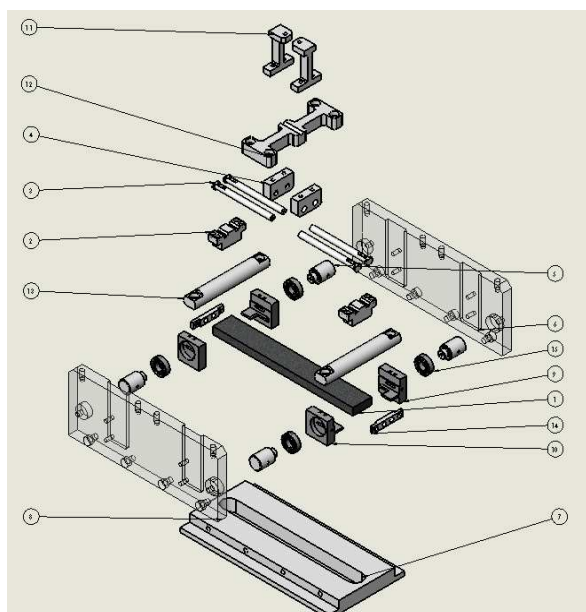

Fig. 6 Component of curvature adjustment system

TABLE I
 DETAILS OF MECHANICAL PARTS OF CURVATURE ADJUSTMENT SYSTEM

No.	Detail
1	Mirror
2	Top clamber
3	Arm bender
4	Arm combiner
5	Shaft
6	Right plate for bender
7	Base plate for bender
8	Left plate for clamber
9	Right Mirror clamber
10	Left Mirror clamber
11	Pulling up bar
12	I bridge
13	Bender handle
14	Bracket for SP
15	BS 6267 RBB-1015-Full,DE ,AC,Full_68

III. FINITE ELEMENT METHOD SIMULATION

All simulation components of curvature adjustment system are designed and used COSMOSWorks to analyze in finite element method. The test of mechanical system is to find the relation between various forces that are applied and variation of curvature radius of mirror to obtain. Furthermore, the apply force to make failure of the system takes into account.

A. COSMOSWorks characteristics

This project uses COSMOSWorks engineering program to use FEA (finite element analysis) in analysis of characteristics of mirror such as strength and curvature of mirror by applying force to the system. Solidworks and COSMOSWorks program work together and link information between. All components of the system create on Solidwork and analyze with COSMOSWorks. Analysis process starts from meshing geometry into small elements linked together. FEA uses partial differential equation rendering and finding the approximating system. Steps of the process divided into three basic processes as follow:

1. Preprocessing is to assign suitable material properties, and apply boundary conditions in the form of restraints and loads.
2. Solution is to calculate and solve the resulting set of equations.
3. Postprocessing is to view the results in forms of plots, contour diagrams etc.

In FEA simulation, properties of mirror defined are Al Alloy(6061) and Zerodur [7] as shown in table II and table III, respectively. Both materials have a dimension of 40mm x 300mm x 15mm. However, this research especially considers

to simulate the holder set of mirror and mirror shown in figure 7.

TABLE II
PROPERTIES OF AL ALLOY(6061)

Property	Value	Unit
Elastic Modulus	69,000	N/mm ²
Poissons Ratio	0.33	-
Shear Modulus	26,000	N/mm ²
Thermal Expansion Coefficient	2.4x10 ⁻⁵	-
Density	0.0027	g/ mm ³
Thermal Conductivity	170	W/ m K
Conductivity	1,300	J/Kg K
Specific Heat	124.084	N/mm ²
Tensile Strength	55.1485	N/mm ²
Yield Strength		N/mm ²

TABLE III
PROPERTIES OF ZERODUR

Property	Value	Unit
Abbe Constant	66	-
Dispersion (n _F -n _C)	0.00967	-
Density	2,530	kg/m ³ @ 25 C
Young's' Modulus	9.1x10 ⁹	N/m ²
Poisson's Ratio	0.24	-
Specific Heat	2.99329	J/Kg K
Coefficient of Thermal Expansion	0.05+0.10x10 ⁻⁶	/C (20-30 C)
Maximum Temperature	600	C

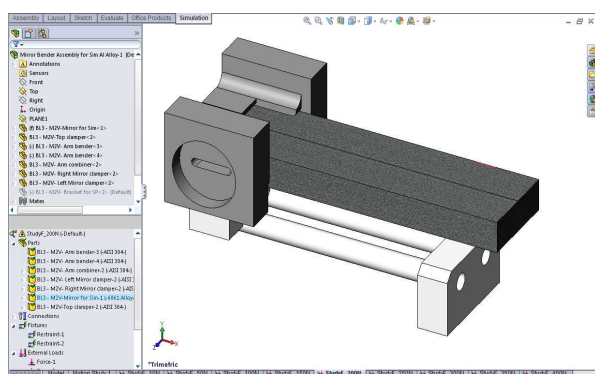

Fig. 7 Simulation of system by COSMOSWorks

IV. RESULTS AND DISCUSSION

From simulation results, various forces plotted are shown in figure 8 and 9. The results from simulation are brought to math lab to find curvature radius and indicate that the more increasing force, the more decreasing curvature radius. The relation between applied force and variation of curvature

radius is shown in table IV and figure 10. Half of structure is used as there is symmetric shape and it saves time when running simulation.

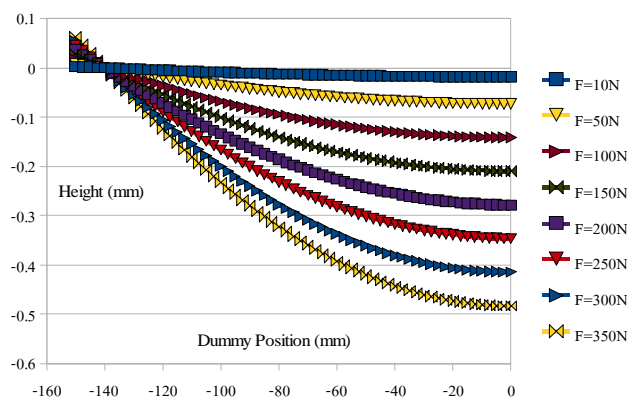

Fig. 8 Relationship between Al-Alloy(6061) position and gaining distance

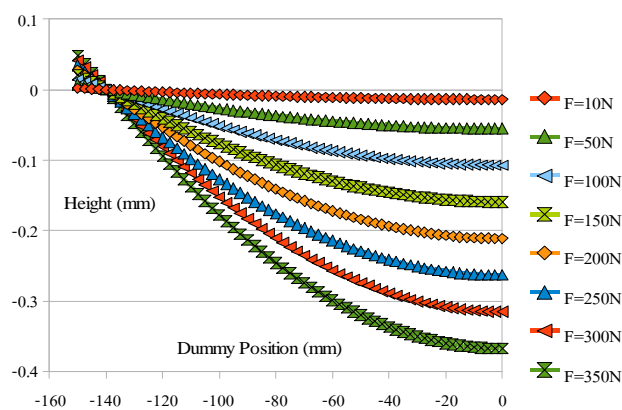

Fig. 9 Relationship between Zerodur position and gaining distance

Figure 10 shows the results from two (3) and (4) that input of load force set 50-350 N is in function of invitation of curvature radius [8]. The simulation results are summarized in Table V.

$$R_{Al\ Alloy(6061)} = -3E-07x^5 - 0.181x^3 + 42.63x^2 - 5221x + 31371 \quad (3)$$

TABLE IV
VARIATION OF CURVATURE RADIUS TO LOADING FORCE APPLYING TO SYSTEM BETWEEN AL-ALLOY (6061) AND ZERODUR

Al Alloy (6061)		Zerodur	
Force (N)	Radian (mm)	Force (N)	Radian (mm)
10	556,051.00	10	731,806.00
50	138,868.00	50	182,034.00
100	71,633.30	100	93,859.80
150	48,283.50	150	63,239.80
200	36,411.00	200	47,679.70
250	29,230.70	250	38,259.20
300	24,411.30	300	31,954.60
350	20,957.20	350	27,437.70

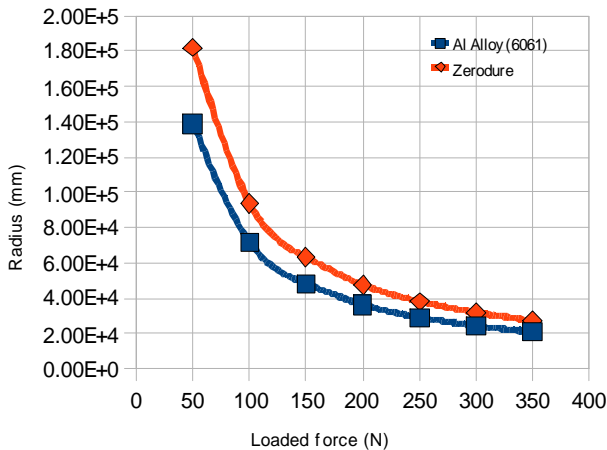

Fig. 10 Relationship between loading force and variation of curvature radius

TABLE V
 THE LOADING FORCE AND CURVATURE RADIUS FROM SIMULATION

Force (N)	Radius (mm)
10	556,051.00
50	138,868.00
100	71,633.30
150	48,283.50
200	36,411.00
250	29,230.70
300	24,411.30
350	20,957.20
400	31,575.10

$$R_{Zerodur} = 1E-09x^6 - 2E-06x^5 + 0.001x^4 - 0.400x^3 + 75.88x^2 - 8,034x + 43,720 \quad (4)$$

where x is the value of the force to a system in Newton unit and R is the radius of curvature change is in millimeter unit.

V. CONCLUSION

This research presents the development of mirror curvature adjustment system for synchrotron light to apply in beamline 3 at Synchrotron light research institute (Public organization). Design processes have complexity since knowledge of engineering has to be applied such as mechanical, electrical, computer and physics etc. This design system is two-arm curvature adjustment which has the advantage of adjusting force freely to both sides of arm. In a case of system assembly or installation might shift the center its system out from position making the ease of focusing beam hitting on the most of Field of view of X-PEEM technique for high accuracy and performance.

The simulation results of curvature adjustment system suitable for using in curvature radius of 50,000-60,000 mm range. In this range, it is able to focus all parts of beam light hitting on field of view of X-PEEM measurement. In addition, loading force at 50-100 N are suitable for Al Alloy(6061)

material having dimension of 300mm x 40mm x 15mm. The loading force in real experiment result is less than 50 N in FEA simulation results that helping less system damage. The different result of both results occurs since all mechanical parts of the system operate and some forces passes through them as virtual force to start initial stage of the system.

ACKNOWLEDGEMENT

This research work is supported by Suranaree University of Technology. Helps and supports from engineers in beam-line at SLRI are greatly appreciated.

REFERENCES

- [1] P. Songsirithigul, B. Kjomrattanawanich, A. Tong-On and H. Nakajima, "Design of the First undulator beamline for the Siam Photon Laboratory," *Nuclear Instruments and Methods in Physics Research, A* 582, 2007, pp. 100-102.
- [2] H. A. Padmore, M.R. Howells, S.Irick, T.Renner, R. Sandler and Y. M. Koo, "Some new schemes for producing high-accuracy elliptical X-ray mirrors by elastic bending," *Proc. SPIE*, Denver, Co Aug, 1996.
- [3] W. C. Young, *Roark's Formula for Stress and Strain*, 6th ed, McGraw-Hill, 1989.
- [4] A. C. Ugural and S. K. Fenster, *Advanced Strength and Applied Elasticity*, 3rd ed, Englewood Cliffs: Prentice Hall, 1995.
- [5] L. Zhang, R. Hustache, O. Hignette, E. Ziegler and A. Freund, "Design optimization of a flexural hinge-based bender for X-ray optics," *J. Synchrotron Rad.* 5, 1998, p. 804-807.
- [6] N. Kamachi, K. Endo, H. Ohashi and T. Ishikawa, "Characteristics of Mechanically-Bent-Shaped Mirror," *2nd International workshop on Mechanical Engineering Design of Synchrotron Radiation Equipment and Instrumentation (MEDSI02)*, Argonne, Illinois, USA, 2002, pp. 113-121.
- [7] M. R. Howells and R. A. Paquin, "Optical Substrate materials for Synchrotron Radiation Beamlines," *SPIE Optical Science, Engineering and Instrumentation*, LBNL-40659, UC-410, pp. 2-6, 1997.
- [8] A. Suthumapiwat, A. Oonsivilai, P. songsirithigul, P. Pao-La-Ord, B. Marungsri and M. Sophon, "Desing Study of Mirror Bender for a Synchrotron Light Beamline," *Proc. Int Conf. on Science Techology and Innovation for Sustainable Well-Being (STISWB)*, Thailand, July 2009, pp. 390-394.