

A Microscopic Simulation Model for Earthmoving Operations

Jiali Fu

Abstract—Earthmoving operations are a major part of many construction projects. Because of the complexity and fast-changing environment of such operations, the planning and estimating are crucial on both planning and operational levels. This paper presents the framework of a microscopic discrete-event simulation system for modeling earthmoving operations and conducting productivity estimations on an operational level. A prototype has been developed to demonstrate the applicability of the proposed framework, and this simulation system is presented via a case study based on an actual earthmoving project. The case study shows that the proposed simulation model is capable of evaluating alternative operating strategies and resource utilization at a very detailed level.

Keywords—Earthmoving operation, microscopic simulation, discrete-event simulation

I. INTRODUCTION

HEAVY construction is one of the largest industries in the world. Examples of common heavy construction include highway and road construction, mining etc. Construction in general is a complex industry and heavy construction projects in particular are comparatively larger in scope. Earthmoving is an important part of major construction projects involving especially designed heavy equipment with significant purchasing/leasing prices, high operating and maintenance costs. Apart from the high purchasing/leasing and operating cost of equipment, the cost of manpower is also of considerable amount due to reasons like rough working conditions, the training process of the equipment operators etc.

The prime function of construction management is to plan, procure, organize and control the activities of the plant and equipment resources [1]. It is often challenged in making “the right decisions” on both strategic and tactical levels before and throughout a project. Strategic decisions include what equipment to purchase or lease and the quantity of equipment so that the project will be completed within the targeted timetable and budget. At the strategic planning stage, the long-term decisions are made with the entire project as the target; while at the tactical level, management focuses on short-term operating issues and resolution of issues that come up due to the uncertainty of the operating environment.

Thus, both strategic and tactical productivity estimations are indispensable for planning and operating purposes. Nevertheless, there are a number of difficulties to overcome due to the uniqueness of construction operations: (1) complex system where many resources collaborate to carry out tasks;

The author is with the Division of Transport and Logistics, KTH Royal Institute of Technology, Stockholm, Sweden (phone: +46-(0)8-790 8007; fax: +46-(0)8-212899; e-mail: jiali.fu@abe.kth.se).

(2) operations are frequently impacted by uncertainties; (3) the ever-changing environment at a construction site. It is therefore important to use methods for total cost estimation at different levels of detail that are appropriate for the targeted applications. The concept of “Total Cost of Ownership” (TCO) is frequently used in construction business. A TCO analysis includes total cost of acquisition, the operating cost and productivity of a project, and gives the management a clear picture of the profitability over time.

Simulation is a widely used tool in operation research and system analysis [2]. The popularity of simulation comes from its ability to model complex systems. Simulation provides realistic representations of the interactions among the systems’ various components while accounting for key uncertainties in the operating environment. Discrete-event simulation has been used for modeling cyclic processes but also for quantitative analysis of complex construction operations. In the past three decades, several simulation systems have been developed specifically for modeling construction operations. In the early 1970s Halpin [3] introduced the CYCLic Operations NETwork (CYCLONE) modeling methodology which modified the conventional Activity Cycle Diagram (ACD) to signify various activities that take place in construction operations. A further development was the creation of the software tool MicroCYCLONE [4] in the 1980s. Many improvements have been made after MicroCYCLONE. Martinez extended CYCLONE and created an advanced graphical simulation software State- and Resource-Based Simulation of COstruction ProcEsses (STROBOSCOPE) [5] and EZStrobe [6]. SIMPHONY [7] is another example of a successful simulation tool that provided more flexible user interfaces and facilitated more complex model development. These tools have been applied on project-level simulations such as productivity measurement, resource planning [8], design and analysis of construction methods [9] and site planning [10].

However, the above-mentioned simulation systems are all macroscopic, *i.e.* designed for productivity analysis at the strategic level. There are a number of limitations, especially for uses related to productivity estimation at the operational level. Examples of limitations include:

- Durations of activities are either deterministic or drawn from stochastic distributions estimated from historical data or field measurements. They are hence not adapted to a fast-changing construction environment or simply not available for new operating conditions. In reality, it might be impossible to collect data due to reasons such as the uniqueness of a

project, regulations or lack of time or personnel for data collection.

- Fuel costs have become a substantial part of operating costs in recent years due to the scarcity of fossil resources and to stricter environmental policies, but this respect was never taken into account by the previous works. A good estimation of fuel consumption will improve the estimation of productivity and total cost of ownership.
- The fleet at construction sites often consists of vehicles of different types and models with various capacities which result in different duration and fuel consumption for carrying out an activity, but most of the existing simulation programs do not characterize features such as the make and model of a piece of construction equipment.

In this paper, a microscopic discrete-event simulation system is proposed for modeling construction operations and conducting productivity estimations on an operational level in terms of TCO. Earthmoving operations are selected as the specific application area since it is the most fundamental operation in construction. The logistics of the physical earthmoving system are represented using the CYCLONE modeling elements. Discrete-event simulation techniques are used to capture the interaction between the resources and the randomness of each of the activities.

Compared to previous works, this microscopic model represents individual equipment at a very detailed level and comprehensive vehicle dynamics are employed to obtain the duration and fuel consumption of each earthmoving activity. The included comprehensive models of vehicle dynamics incorporate the impact on performance of several factors such as characteristics of earth, road geometry, payload, and provide accurate estimations of activity duration and fuel consumption. These estimations are then used as the input into the discrete-event simulation. Subsequently, suitable probability distributions from previous studies of the duration and fuel usage are used to describe the randomness of these two respects. In addition, this simulation module also includes the flexibility to characterize resources.

A prototype has been developed to demonstrate the applicability of the proposed framework, and this simulation system is presented via a case study based on an actual earthmoving project. The case study shows that the proposed simulation model is capable of evaluating alternative operating strategies and resource utilization at a very detailed level. It supports a better understanding of the interactions between resources, and the impact of improvement in the operating characteristics of equipment, operator behavior etc.

II. MODELING EARTHMOVING OPERATIONS

Modeling earthmoving operations correctly is essential to ensure the creditability of simulation. The CYCLONE modeling methodology is the most commonly used in modeling construction operations and will be employed in this paper.

The CYCLONE model introduces symbolic elements to build networks of active and idle states to represent cyclic processes which are common in earthmoving operation. Fig.1 shows the basic CYCLONE elements for modeling earthmoving operations.





Name	Symbol	Function
Normal activity		Unconstrained activity. Entities arriving at a Normal node will be processed directly without delay.
Combination Activity (Combi)		The constrained work task modeling element, is logically constrained in its starting logic but otherwise similar to the normal work task modeling element.
Queue node		The idle state of a resource entity symbolically representing a queuing or waiting for use of passive state of resources.
Arrow		The resource entity directional flow modeling element.
Counter		Keeps track of the number of times units pass it.

Fig.1 The basic CYCLONE modeling elements.

The most basic operation in earthmoving is the load and haul process which consists of single or multiple loading units and hauling units. Due to the limited space on construction sites, it is rare to have multiple loading stations. The focus of this paper is thus on the case of a single loading station.

Wheel loaders (WL) and excavators (EXC) are commonly used equipment for loading purposes. Depending on the material state and ground space limitations, one equipment type is more appropriate than the other. In general, wheel loaders have larger bucket volume but require a certain space to enable reversing and driving forward to load. They are mostly suitable for loading ready excavated and stockpiled material. In contrast, excavators have small bucket volume but can load while remaining on the same spot. Excavators can also dig material from their untouched natural state. Excavators are normally placed on higher ground relative to haulers in order to ease loading.

The macroscopic level activities and work cycles that take place in a load and haul operation are described in the following by an example consisting of one loading unit and two haulers. In the beginning of a shift, all loading and hauling units start at the loading station (LS). The operation commences with the loading unit loading the first hauler. The loaded hauler then travels to the dumping station (DS) to dump its load. As soon as the loaded hauler leaves the LS, the second hauler in queue drives into the loading spot and another loading activity begins. While at the DS, the first hauler empties its load and travels back to the LS for

reloading. Using the CYCLONE modeling method, this load and haul process is graphically represented in Fig. 2. In this process, the only queues (queue node 1 for the loader and queue node 2 for the haulers) occur at the loading station. The queue for haulers is emptied according to the “First In, First Out” (FIFO) principle.

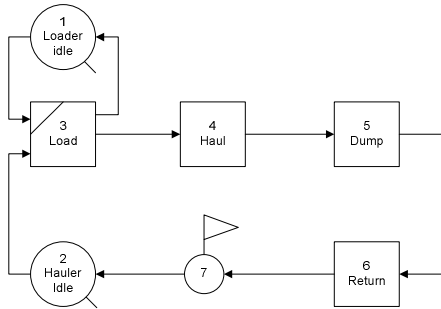

Fig. 2 The basic load and haul process.

For crushing purpose, the dumping station is equipped with a stationary/mobile crusher with a hopper connected on top, which works as a container to hold material to be crushed. Each crusher is designed to crush raw material with a certain maximum size at a specified crushing rate, and the crushed material is delivered to a screening machine which separates the material according to its size and transfers it for further processing.

When a hauler arrives at the DS, it reverses to the opening of the hopper and rear-dumps its load into the hopper. In operation only one hauler can dump at the time, a queue node (node 6 in Fig. 3) is therefore created at the DS to represent the state of the dumping station being busy or idle. Haulers have to wait at the queue node 5 if the dumping station is occupied by another hauler. The crusher’s crushing rate and the size of the hopper are also determining factors of the state of the DS. After dumping, the material is stored in the hopper and fed into the crusher and crushed into smaller size at a certain rate. Normally, haulers do not dump if there is not enough space for its entire load in the hopper. Fig. 3 shows the CYCLONE diagram for load and haul operations including the dumping station equipped with a crusher. The CYCLONE diagrams in this paper will only give a graphical overview of earthmoving operations, and the details of operation are not explicitly illustrated.

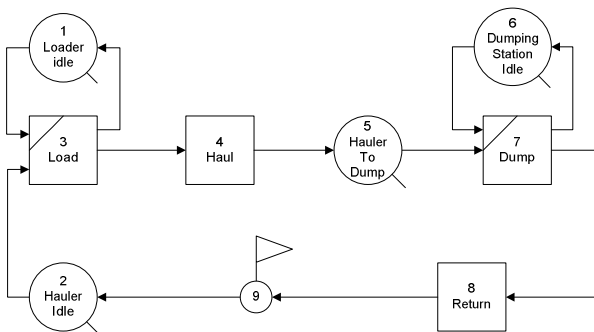

Fig. 3 Load and haul process with a crusher at the dumping station

Furthermore, the loading activity could be broken into two moments: fill the loading unit’s first bucket, and load. Firstly, the loading unit fills its first bucket, holds it in a proper position and waits for the hauler. The hauler then drives or reverses to the spot so that its trailer is under the loading unit’s bucket. Subsequently, the loading unit empties its first bucket into the hauler and continues to load until the hauler is full. Fig. 4 shows the CYCLONE graphical representation with filling loader’s first bucket and loading as two separate activities. The “Fill 1stBucket”-activity is modeled as a Combi since Queue has to be followed by Combi element using the CYCLONE modeling method.

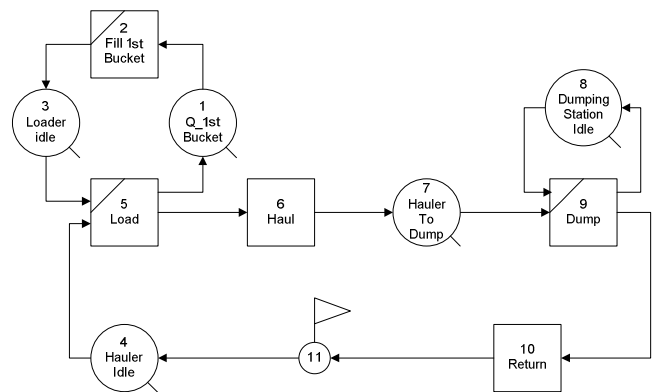

Fig. 4 Load and haul process with filling first bucket as a separate event

III. MICROSCOPIC DISCRETE EVENT SIMULATION MODEL

The state variables in the CYCLONE modeling diagram change at discrete time instances, for examples when the number of haulers waiting in the queue for loading changes. We apply a discrete-event simulation method to evaluate the operation numerically and advance the simulation clock using the next-event time-advance approach. Fig. 5 illustrates the framework of the proposed microscopic simulation model.

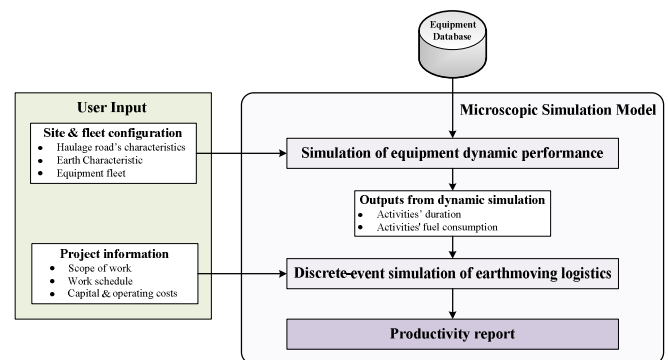

Fig. 5 The framework of microscopic simulation model

Using the suggested framework, the user is encouraged to provide information regarding site and fleet configuration and the targeted project (the left block in Fig. 5). The site and fleet configuration contains the haulage route data (length, slope, curvature, rolling resistance, maximum speed of each route

segment etc.), the characteristics of the material (density, excavation class and fill factor), and the equipment fleet configuration. This information is utilized together with the stored equipment database to compute the duration and fuel consumption of earthmoving activities which is explained later in this section. The project information refers to the scope (total amount of earth to be moved, targeted production etc.), work schedule (working hours per day, coffee and lunch break length) and the cost data. This information and the outcome from dynamic simulation are then used to conduct discrete-event simulation to generate the TCO analysis and productivity report. The TCO concept is further clarified in this section.

A. Activities' Duration and Fuel Consumption Modeling

Accurate modeling of the input is the key to a successful simulation experiment. In our study, the durations of interest are loading, hauling, dumping and returning time. The final payload is the outcome of the loading activity and it is the payload of material a hauler carries when it leaves the LS. Loading time refers to the time taken for loading unit to complete the payload. Hauling time is the time needed for a hauling unit to travel from the LS to the DS, and returning is the reverse trip. Normally, it takes longer time to travel to the DS than to return due to the load. Finally, the dumping time is the time required for a hauling unit to dump its load at the DS.

The most common approach to estimate the durations of activities is to use historical data from previous construction projects. Many studies show that the uniform, triangular, normal, lognormal [11], beta [12] and Erlang [8] distributions are suitable to model duration of repetitive construction processes.

Kannan [13] provided a comprehensive study in extracting and quantifying the variations of each activity in earthmoving operations. In his work, Kannan proposed two scenarios to examine the loading activity and different process schemes for developing performance measures for the activities. One is to assume that there is no correlation between the loading time and payload, and to develop a probability distribution function separately. The other scenario is that the payload and loading time have a joint probability since the payload is dependent of the loading time. For the haul and return time, Kannan pointed out that it is not possible to develop reference values for every possible haul route and dynamic models should therefore be employed to obtain relatively accurate activity times. Using the performance data given by manufactures is another alternative [14] to obtain relatively correct estimations of the activity durations.

In this microscopic simulation, the durations of all earthmoving activities are obtained from the Global Simulation Platform (GSP)-an in-house simulation environment provided by Volvo Construction Equipment (Volvo CE). GSP has an intuitive graphical user interface and simulates the behavior of four major vehicle subsystems in wheel loaders and articulated haulers (AH): hydraulics, powertrain, thermal management and an actual operator.

This platform is designed for product development and serves as a common language to compare design alternatives, predict fuel consumption and equipment operability within Volvo CE, and is regarded as highly accurate compared to the actual vehicles.

In GSP, the operator behavior is created using the recorded operating data and represents a driver with average experience and skill which results in a deterministic output. The operators' behavior is a very important input factor which varies not only with driver ability, but also depending on how different experienced drivers will react to different road conditions. Thus, it is necessary to take account of the randomness of the operator's behavior in the simulation. We therefore take the output from GSP simulation as the mean value of activities' duration and fuel usage, and use suitable probability distributions from previous studies to describe the randomness of these two aspects.

B. TCO Concept and Productivity Report

The TCO analysis is commonly used in construction business for estimating the direct and indirect costs of production. Conceptually, TCO is a management accounting term which evaluates the economic value of an investment. A TCO analysis includes the acquisition cost, the operating cost and productivity, and gives the project management a clear picture of the profitability over time. Three key elements of TCO are total cost, production and cost per unit. The common challenge of TCO analysis is the collection of appropriate and accurate data.

The total cost C_{tot} of TCO includes the capital cost C_{cap} and operating cost C_{opr} , where C_{cap} covers the equipment's purchasing price, residual value, depreciation, interest, insurance and taxes while C_{opr} takes account of those costs which result from equipment operation and use. Normally, the operating cost includes operator cost, fuel consumption, wear parts, preventive maintenance and repair cost. Production per hour P is the output of a fleet of equipment working together, and is defined in a weight measurement (ton/h) or a volume measurement (m^3/h). Finally, TCO is defined as the cost per production unit and is obtained as the quotient between the total cost per hour and the production per hour. Nevertheless, naively minimize the TCO might reduce the production rate and extend the time required to finish a target project. Other performance measures like the production rate, the expected project duration and profitability should not be disregarded in the productivity analysis.

IV. CASE STUDY

A case study of earthmoving operation is carried out in this section to demonstrate the applicability of the proposed simulation framework. The Vällsta quarry is located in the north of Stockholm, Sweden and it produces gravel, aggregate, and sand in different sizes. The uncrushed material is mostly obtained by blasting rocks into large pieces on site, and also other construction sites transport rocks here for crushing purpose. The project management receives a delivery of rocks with density of $1.60 \text{ ton}/m^3$ and they have a wheel loader and

two articulated haulers of same model available. We will employ the proposed microscopic simulation model to test different loading strategies and perform sensitivity analysis. TABLE presents the information of this earthmoving operation.

TABLE I
 OPERATING INFORMATION OF VÄLLSTA SITE

	Value	Unit
Material density	1.60	ton/m ³
Wheel load fill factor	1.10	
Number of loading unit	1	
Number of hauling unit	2	
Bucket volume of loading unit	5	m ³
Payload of hauling unit	39	ton
Hopper volume	50	m ³
Crusher capacity	500	ton/h
Fuel price	15	SEK/liter
Product price	100-200	SEK/ton

A loading strategy includes the full-bucket and the full-hauler options, and it decides whether or not the last bucket of the loading unit should be placed in the hauling unit. The full-bucket option assumes that the hauler will only be loaded with relative full bucket loads. The common cut-off point for rejecting or accepting the last bucket lies between 75% and 95%. The full-hauler strategy allows the loading unit to fill the hauler full, even if the last load is only a portion of a full bucket. By a rule of thumb in construction business, the cut-off value for rejecting or accepting the last bucket is between 20% and 40%. The full-hauler loading strategy is normally recommended by equipment manufacturers.

Using the numerical values given in TABLE , it requires 4.43 buckets to load the hauler full. Applying the full-hauler option, the loader operator should fill haulers full with the 5th bucket load.

$$\frac{\text{hauler capacity}}{\text{bucket volume} \cdot \text{material density} \cdot \text{fill factor}} = \frac{39}{5 \cdot 1.6 \cdot 1.1} \approx 4.43$$

We will conduct simulation with three different scenarios with varying loading strategies given in TABLE . The earthmoving operation is modeled as in Fig. 4 where filling the first bucket action is modeled as a separate event. Using the GSP dynamic simulation provided by Volvo CE, we obtain the duration and fuel consumption of each activity. The most significant activities' durations are modeled as probability distribution functions. For instance, the duration of loading activity T_{load} is defined as a normal distribution $T_{load} \in N(\mu_{load}, \sigma_{load})$, where μ_{load} is taken from GSP simulation and σ_{load} is the standard deviation obtained from other studies.

TABLE II
 THREE SCENARIOS WITH DIFFERENT LOADING STRATEGIES

	Scenario 1	Scenario 2	Scenario 3
Loading strategy of hauler 1	full-bucket	full-bucket	full-hauler
Loading strategy of hauler 2	full-bucket	full-hauler	full-hauler

The Vällsta site has an 11-hours work shift daily with a one-hour lunch break in the middle of the day and a 15-minutes coffee break both in the morning and in the afternoon. As an initialization condition, all loading and hauling units start the operation at the loading station and the discrete-event simulation terminates at the end of each shift. Before each break, the operator of loading unit checks if there is enough time to complete an entire load and haul cycle for the first hauler in the queue. Then the operator fills the first bucket if there is enough time or terminates the loading operation in case of time deficiency. The simulation is performed for 30 working days and TABLE shows the average values of TCO, the daily productivity, and queue statistics of each hauler and so forth for the three scenarios in TABLE .

TABLE III
 SIMULATION RESULTS OF EARTHMOVING OPERATION WITH 3 DIFFERENT LOADING STRATEGIES

	Scenario 1	Scenario 2	Scenario 3
Number of load and haul cycles	216.83	196.57	179.37
Production[ton]	7 632.53	7 349.91	7 102.92
Fuel consumption [liter]	606.15	581.37	559.82
TCO [SEK/ton]	5.1235	5.2796	5.4259
Fuel cost per unit production [SEK/ton]	1.1912	1.1865	1.1822
WL idle time [minute]	6.74	0.69	0.09
WL idle time due to breaks [minute]	98.31	99.48	99.42
AH queuing time at LS [minute]	105.87	166.67	147.19
AH queuing time due to breaks[minute]	93.51	96.71	97.90
AH queuing time at DS [minute]	26.47	0.07	0
	26.86	0.01	0

The first scenario is certainly superior with the lowest average unit cost of 5.1235 SEK/ton, which gives a reduction in production cost of $(5.4259 - 5.1235) \cdot 7632.53 = 2308.08$ SEK per day compare to scenario 3. Evaluating the results from the point of view of sales profit, the scenario 1 gives an average profit increase of at least $(7632.53 - 7102.92) \cdot 100 - (606.15 - 559.82) \cdot 15 \approx 52266$ SEK per day, where the first terms are the increase in income and

are deducted by the cost of higher fuel usage. Thus the first scenario gives an increase of 6.8% in revenue and should be recommended to the project management. We observe that the fuel cost is a significant part of TCO, approximately 23% of the unit cost in all three scenarios. Therefore, an accurate estimation of fuel usage is essential in productivity analysis. Moreover, we could conclude that the full-bucket loading option for both haulers is more beneficial in this case.

The queuing statistics for loader and haulers are divided into two categories: queuing time due to unavailability of other resources and due to breaks (coffee breaks and lunch). For instance, during the coffee and lunch breaks the loader waits in the queue node 1 (in Fig. 4) to fill first bucket. Hence, the loader's queuing time in this node is because of breaks, and the queuing time at the node 3 is caused by the unavailability of hauler due to various reasons such as mismatch of loader/haulers, crusher capacity limitation etc. Similarly, haulers' idle time at the LS are divided into two groups. This information gives us a valuable insight of equipment matching. Haulers' queuing time at the DS is due to either the DS being occupied by another hauler or there no being enough space for the hauler's load. The first case seldom occurs if both haulers are of same model, and the crusher capacity limit is the main reason for causing congestion at the DS. From TABLE we observe delays at the DS for both haulers in scenario 1 which indicates that the crusher's maximum capacity has been reached.

V. CONCLUSION

This paper presents a microscopic discrete-event simulation model designed for earthmoving operations. A case study of an actual earthmoving project has been conducted and evaluated to demonstrate the applicability of the simulation model. The productivity analysis is measured using the unit cost, which is doubtlessly the most important measure, and also by other aspects such as daily production and profit. The case study shows that the proposed simulation model performs the sensitivity analysis on a detailed level and hence is a useful tool for the decision-makers to evaluate different resource combinations and operational alternatives with a high level of accuracy rather than only relying on experience and rules of thumb.

Until now, the GSP dynamic simulation has given the equipment development engineers the possibility to examine and optimize the equipment performance from the design point of view. But to study the performance as an entire fleet, there is not yet a proper tool. The proposed microscopic model can hence serve as a tool for product development purposes.

However, there are aspects that affect the performance of earthmoving operation which we have not taken into consideration, such as the weather, the eventual breakdown of equipment etc. The studied crushing plant operates all year around and the weather condition varies hugely throughout the year in Stockholm. For instance, during winter seasons the icy and snow-covered/frozen ground will force hauler operators to reduce their travelling speed. The resistance of the materials also increases.

These will in turn enlarge the excavation and haulage time, as well as the fuel expenditure. These additional factors need to be considered to further improve the simulation model's accuracy.

REFERENCES

- [1] D. J. Edwards and G. D. Holt, "Construction plant and equipment management research: thematic review," *Journal of Engineering, Design and Technology*, vol. 7, no. 2, pp. 186-206, 2009.
- [2] A. Law and W. D. Kelton, *Simulation modeling and analysis*, McGraw-Hill: New York, NY, 2000.
- [3] D. W. Halpin, "An investigation of the use of simulation networks for modeling construction operations," PhD dissertation, Department of Civil Engineering, University of Illinois at Urbana-Champaign, Urbana, IL, 1973.
- [4] J. F. Lulich and D. W. Halpin, "Construction operation and microcomputers," *Journal of the Construction Division, ASCE*, vol. 108, no. 1, pp. 129-145, 1982.
- [5] J. C. Martinez, "Stroboscope," PhD dissertation, University of Michigan, Ann Arbor, MI, 1996.
- [6] J. C. Martinez, "EZSTROBE - introductory general-purpose simulation system based on activity cycle diagrams," in *Proceedings of the 2001 Winter Simulation Conference, Society for Computer Simulation*, 2001.
- [7] S. M. AbouRizk and D. Hajjar, "A framework for applying simulation in construction," *Canadian journal of civil engineering*, vol. 25, no. 3, pp. 604-617, 1998.
- [8] M. M. Hassan and S. Gruber, "Application of discrete-event simulation to study the paving operation of asphalt concrete," *Construction Innovation: Information, Process, Management*, vol. 8, no. 1, pp. 7-22, 2008.
- [9] J. A. Vanegas, E. B. Bravo and D. W. Halpin, "Simulation technologies for planning heavy construction processes," *Journal of Construction Engineering and Management*, vol. 119, no. 2, pp. 336-354, 1993.
- [10] A. Gannoruwa and J. Y. Ruwanpura, "Construction noise prediction and barrier optimization using special purpose simulation," in *Proceedings of the 39th conference on Winter simulation*, 2007.
- [11] L. D. Graham, S. D. Smith and P. Dunlop, "Lognormal distribution provides an optimum representation of the concrete delivery and placement process," *Journal of Construction Engineering and Management*, vol. 131(2), pp. 230-238, 2005.
- [12] S. M. AbouRizk and D. W. Halpin, "Statistical properties of construction data," *Journal of Construction Engineering and Management*, vol. 118, no. 3, pp. 525-544, 1992.
- [13] G. Kannan, "A methodology for the development of a production experience database for earthmoving operations using automated data collection," PhD dissertation, Virginia Polytechnic Institute and State University, 1999.
- [14] S. D. Smith, G. S. Wood and M. Gould, "A new earthworks estimating methodology," *Construction Management and Economics*, vol. 18, no. 2, pp. 219-228, 2000.