

Hydrogen Integration in Petrochemical Complexes, Using Modified Automated Targeting Method

M. Shariati, N. Tahouni, A. Khoshgard, M.H. Panjeshahi

Abstract—Owing to extensive use of hydrogen in refining or petrochemical units, it is essential to manage hydrogen network in order to make the most efficient utilization of hydrogen. On the other hand, hydrogen is an important byproduct not properly used through petrochemical complexes and mostly sent to the fuel system. A few works have been reported in literature to improve hydrogen network for petrochemical complexes. In this study a comprehensive analysis is carried out on petrochemical units using a modified automated targeting technique which is applied to determine the minimum hydrogen consumption. Having applied the modified targeting method in two petrochemical cases, the results showed a significant reduction in required fresh hydrogen.

Keywords—Automated targeting, Hydrogen network, Petrochemical, Process integration.

I. INTRODUCTION

PROCESS integration methodologies in hydrogen networks consist of pinch based conceptual approaches and superstructure based mathematical optimization techniques. Pinch analysis is aimed to minimize the fresh hydrogen consumption and off-gases discharge while maximizing the recovery and reuse of hydrogen by variety of purification techniques.

Alves and Towler [1] first proposed a graphical targeting approach to identify the hydrogen pinch and the minimum hydrogen demand using hydrogen purity and hydrogen surplus profiles. Later, El-Halwagi et al. [2] developed a rigorous and non-iterative graphical method, to minimize the fresh resource consumption. Foo and Manan [3] put forward a numerical targeting method named the gas cascade analysis (GCA) to calculate the utility target.

However, these graphical techniques cannot efficiently consider all possible practical constraints, which lead to the development of various design approaches. Hallale and Liu [4] proposed a mathematical optimization method based on a superstructure to address the pressure constraints in optimizing hydrogen networks. Liu and Zhang [5] developed a detailed model of purification units into the hydrogen network to evaluate possible purification scenarios. Ahmad et al. [6] extended a new approach for multi-period operation. These mathematical methods are preferred to address problems such as optimum cost, flexible operation, specific process constraints, etc.

Both insight-based and mathematics-based optimization techniques have their own advantages. Mathematical methods are preferred to address large-scale problems with complex process constraints. On the other hand, the conceptual methods provide insightful understanding for network synthesis. So, it is worthwhile to take advantages of both methods. Recently, the pinch based automated targeting techniques have been extended to the resource conservation problem including water and hydrogen network by Ng et al. [7], [8]. Flexibility in changing the objective function allows adopting this pinch-based optimization approach to case-specific problem.

In this study the automated targeting technique presented by Ng et al. [7] is modified to consider the pressure swing adsorption (PSA) units or other purification units through the hydrogen network.

II. AUTOMATED TARGETING TECHNIQUE

Pinch analysis technique is less complicated than solving the mathematical model. However, the combination of the pinch concepts and the mathematical model has infrequently been addressed. The automated targeting first proposed mass exchange network synthesis [9] was extended to the resource conservation network (RCN) by Ng et al. [7]. Being flexible in defining an objective function, this approach is superior to the conventional pinch-based techniques. This technique would be used in this study with some modifications.

A. Model for Conventional RCN Problem

According to Ng et al. [7], the first step in conducting the automated targeting technique is to build a *resource conservation cascade diagram* (RCCD), as shown in Fig. 1. As shown, the sinks and sources are first arranged in a descending order, from the highest purity level ($k = 1$) to the lowest level ($k = n$). Next, *material flow rate cascading* and *load cascading* are performed across all purity level.

M. Shariati is MSc Student with the School of Chemical Engineering, College of Engineering, University of Tehran, Iran (e-mail: m.shariati@ut.ac.ir).

N. Tahouni is Assistant Professor with the School of Chemical Engineering, College of Engineering, University of Tehran, Iran (phone: 98-21-66957788; fax: 98-21-66957784; e-mail: ntahuni@ut.ac.ir).

A. Khoshgard is with the Department of Chemical Engineering, Islamic azad University, South Tehran Branch, Iran (e-mail: khoshgrd@azad.ac.ir).

M. H. Panjeshahi is Professor with the School of Chemical Engineering, College of Engineering, University of Tehran, Iran (e-mail: mhpanj@ut.ac.ir).

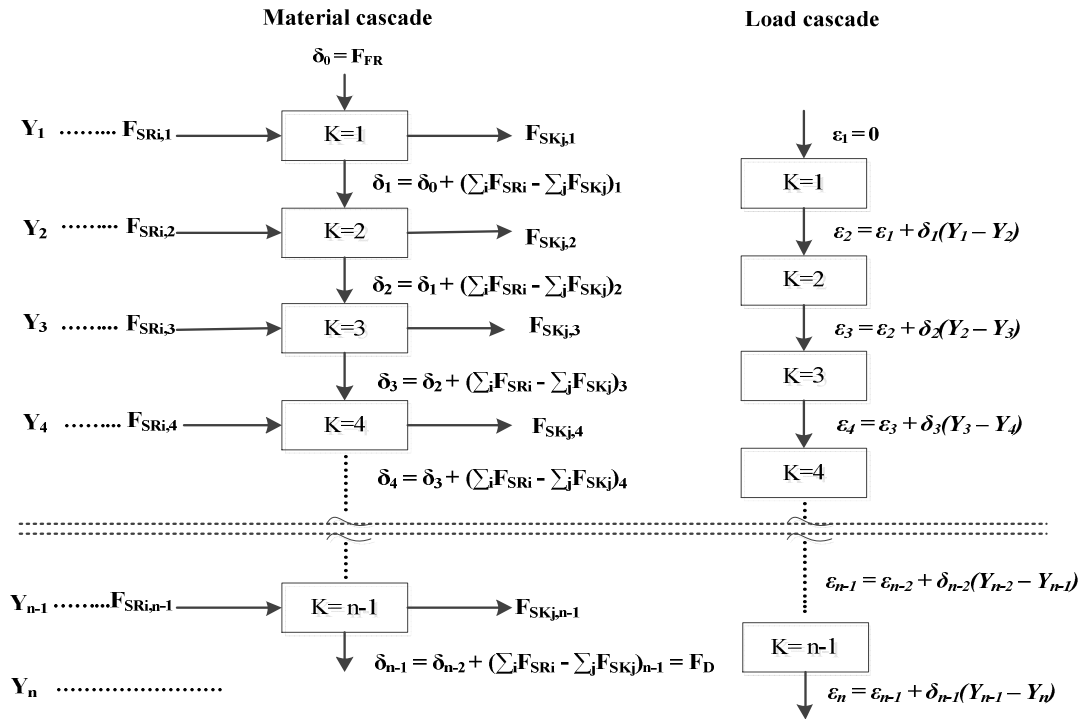

Fig. 1 Resource conservation cascade diagram, RCCD (Ng et al. [7])

Net material flow rate of each purity level (δ_k) is given by

$$\delta_k = \delta_{k-1} + (\sum_i F_{SRi,k} - \sum_j F_{SKj,k}) \quad k \forall K \quad (1)$$

The load balance at the k th purity (ϵ_k) is given as

$$\epsilon_k = \epsilon_{k-1} + \delta_{k-1}(Y_{k-1} - Y_k) \quad k \forall K \quad (2)$$

The residual load, ϵ , must take a positive value to achieve a feasible RCN. Therefore, Equation (3) is included as a constraint in the formulation model.

$$\epsilon_k \geq 0 \quad k \forall K \quad (3)$$

A pinch purity is obtained when the residual load is determined to be zero in the model solution at purity level k ($\epsilon_k = 0$). This is similar to the pinch point in the hydrogen surplus diagram in the graphical targeting approaches where the hydrogen surplus is zero [1].

III. CASE A

Case A is representative of a real petrochemical complex. This typical aromatics complex contains several process units to produce primarily *para*-xylene. Hydrogen plays an important role through this complex since there are several processes which consume hydrogen such as hydrotreatig (HT), hydrogenation (HG), arofining (AF), isomerization (IS), regeneration (RG), transalkylation (TA) and disproportionation (DP). Required hydrogen is supplied from a catalytic reformer.

There is also a purification unit which purifies hydrogen stream leaving catalytic reformer. Prior to design, targeting assists to figure out the scope for the current network potentials. Fig. 2 shows the hydrogen network flowsheet extracted from this petrochemical complex. Table I and II, summarize stream data and sources/sinks data for existing network, respectively. It should be noted that the purge stream of regeneration unit is not used due to process constraints.

A. Modified Model For RCN Problem

In current network, no hydrogen recovery is done on off-gases purged from various units except outlet stream of CRU. Catalytic reforming provides network with a relatively pure hydrogen stream as a by-product. Based on Fig. 3, a portion of this stream is directly sent to several consumers and remaining is sent to a PSA to be purified and then used in other consumers. Therefore, one sink (PSA feed) and two sources (PSA product and residue) are added to the network. The product stream of PSA is regarded as fresh hydrogen resource through the network because of its high purity. In order to reduce the overall hydrogen consumption further, it is worth to apply residue stream from PSA unit to the hydrogen network due to its relatively high purity.

However, PSA feed flow rate and PSA residue flow rate are no longer constant, and have linear relationship with the PSA product flow rate earlier considered as fresh resource. As a result, one sink and two sources added to the network are new variables and modification of mentioned model to address this problem is inevitable.

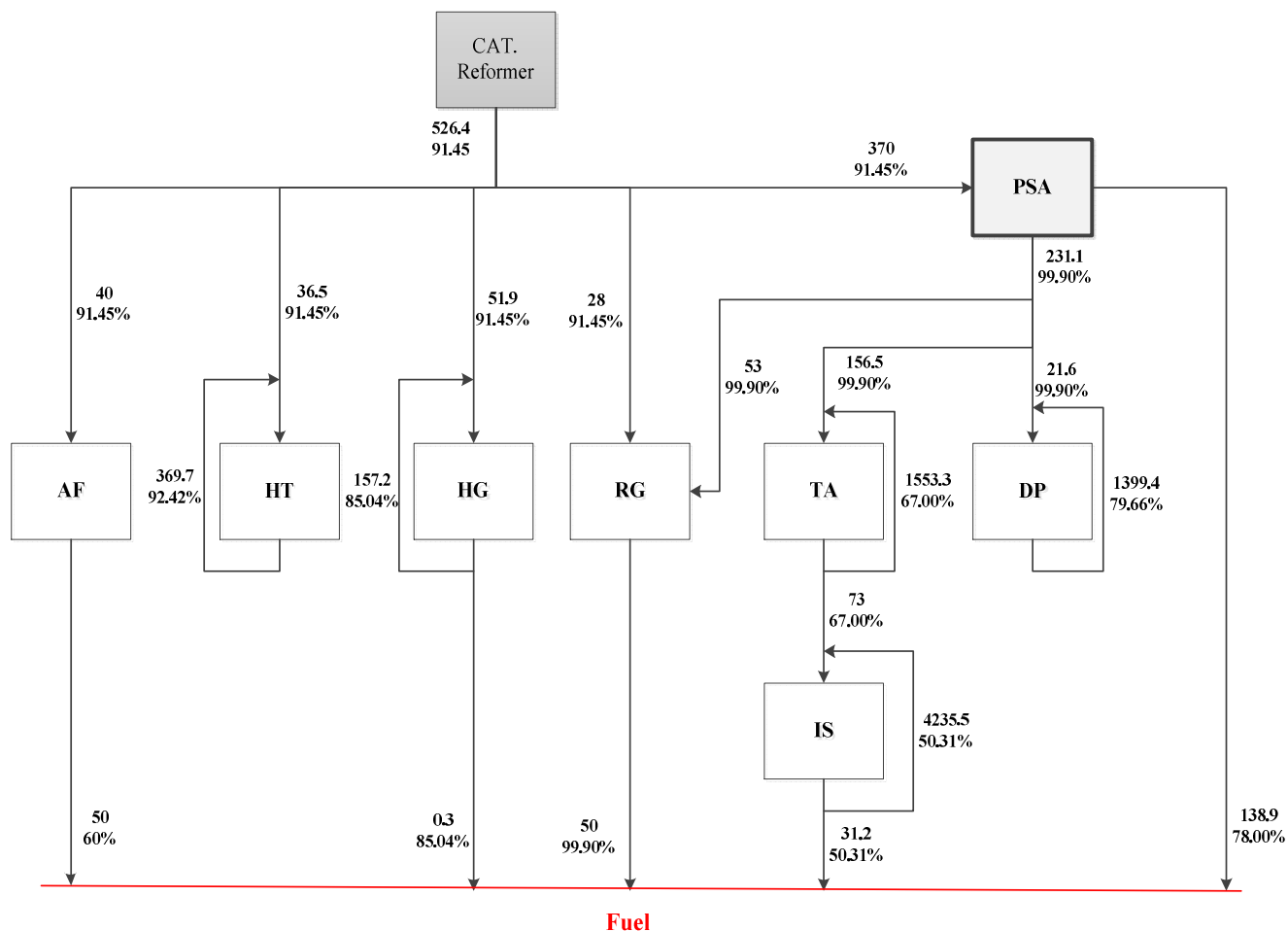

Fig. 2 The existing hydrogen network

The overall flow rate balance of the purification unit is as follow:

$$F_{in} = F_P + F_R \quad (4)$$

Where F_{in} , F_P and F_R are PSA feed, product and residue flowrates.

The relation between feed flow rate and residue flow rate is shown as

$$F_{in} = F_P (Y_P/Y_{in} \times R) \quad (5)$$

Where R is PSA recovery and Y_P and Y_{in} are PSA product and feed purities.

It is assumed that $Y_P/Y_{in} \times R = \alpha = \text{constant}$, so

$$F_{in} = \alpha \times F_P \quad (6)$$

Using (6), the overall balance across purification unit (4) can be simplified as

$$F_R = (\alpha - 1) \times F_P \quad (7)$$

Equation (7) represents the linear relationship between a source of network (PSA residue) and the fresh hydrogen

resource (PSA product). The combination of (1) to (3) and (7) form a linear programming (LP). An objective function needs to be defined. Here, the objective function is minimizing fresh resource flow rate

$$\text{Objective function} = \text{minimize } F_P \quad (8)$$

As previously mentioned, this approach is flexible to take any other objective functions such as minimizing operating cost.

Minimizing Equation (8) subject to the constraints in (1) to (7) is performed by GAMS [10] and the resulted RCCD shown in Fig. 4.

The existing fresh hydrogen consumption is 231.1 mol/s. As shown in Fig. 4, the minimum fresh hydrogen and off-gases discharge flow rates (F_{FR} and F_D) for this case are targeted as 192.45 and 160.25 mol/s, respectively, with the pinch purity located at 67 mol % (Y_{10}). It means 16.7% reduction in fresh hydrogen consumption compared to last required fresh hydrogen of 231.1 mol/s. In addition, the catalytic reformer production is decreased from 526.4 to 466.25 mol/s. It is also environmentally precious as less greenhouse gases are produced.

TABLE I
 STREAM DATA OF EXISTING HYDROGEN NETWORK

Process	Make-UP		Purge		Recycle	
	Flow rate	Purity	Flow rate	Purity	Flow rate	
	(mol/s)	(mol%)	(mol/s)	(mol%)	(mol/s)	
Hydrogenation	51.9	91.45	0.3	85.04	157.2	
Hydrotreating	36.5	91.45	0.0	92.42	369.7	
Disproportionation	21.6	99.99	0.0	79.66	1399.4	
TransAlkylation	156.5	99.90	73.0	67	1553.3	
Isomerization	73.0	67.00	31.2	50.31	4235.5	
Arofining	40.0	91.45	50.00	60.00		
Regeneration	53.0	99.90	50.0	99.90		
	28.0	91.45				
	Feed		Product		Residue	
	(mol/s)	(mol%)	(mol/s)	(mol%)	(mol/s)	(mol%)
PSA unit	370	91.45	231.1	99.90	138.9	78.00
H₂ Supply	Flow rate	Max flow	Purity			
	(mol/s)	(mol/s)	(mol%)			
Catalytic Reforming	526.4	526.4	91.45			

TABLE II
 SOURCE / SINK DATA FOR EXISTING HYDROGEN NETWORK

Source		Sink	
Flow rate	Purity	Flow rate	Purity
(mol/s)	(mol%)	(mol/s)	(mol%)
369.7	92.42	53.0	99.90
526.4	91.45	406.2	92.33
157.5	85.04	438.0	91.45
1399.4	79.66	209.1	86.63
1626.3	67.00	1421.0	80.00
50.0	60.00	1709.8	70.00
4266.7	50.31	4308.5	50.60

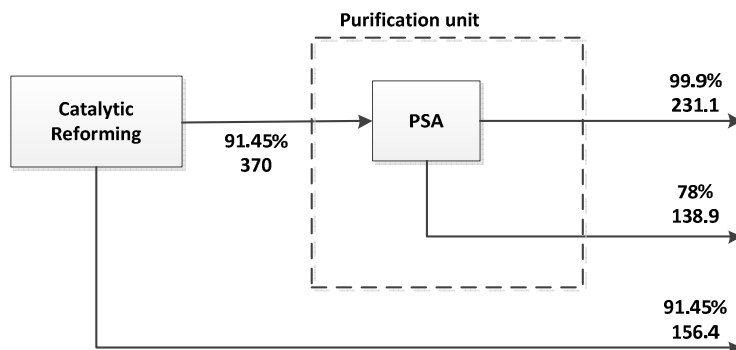

Fig. 3 Catalytic Reforming Unit and its associated purification unit

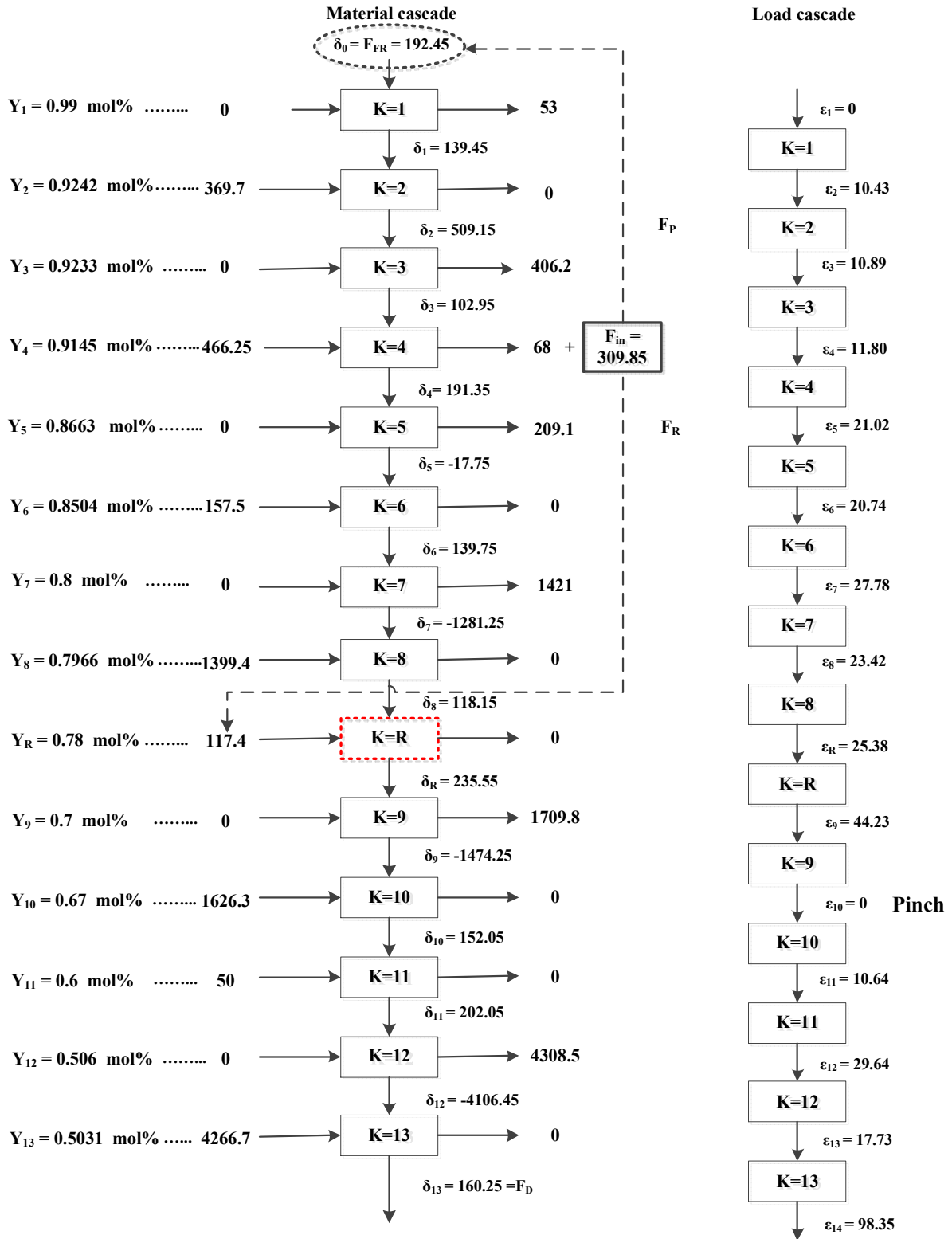

Fig. 4 RCCD for case A

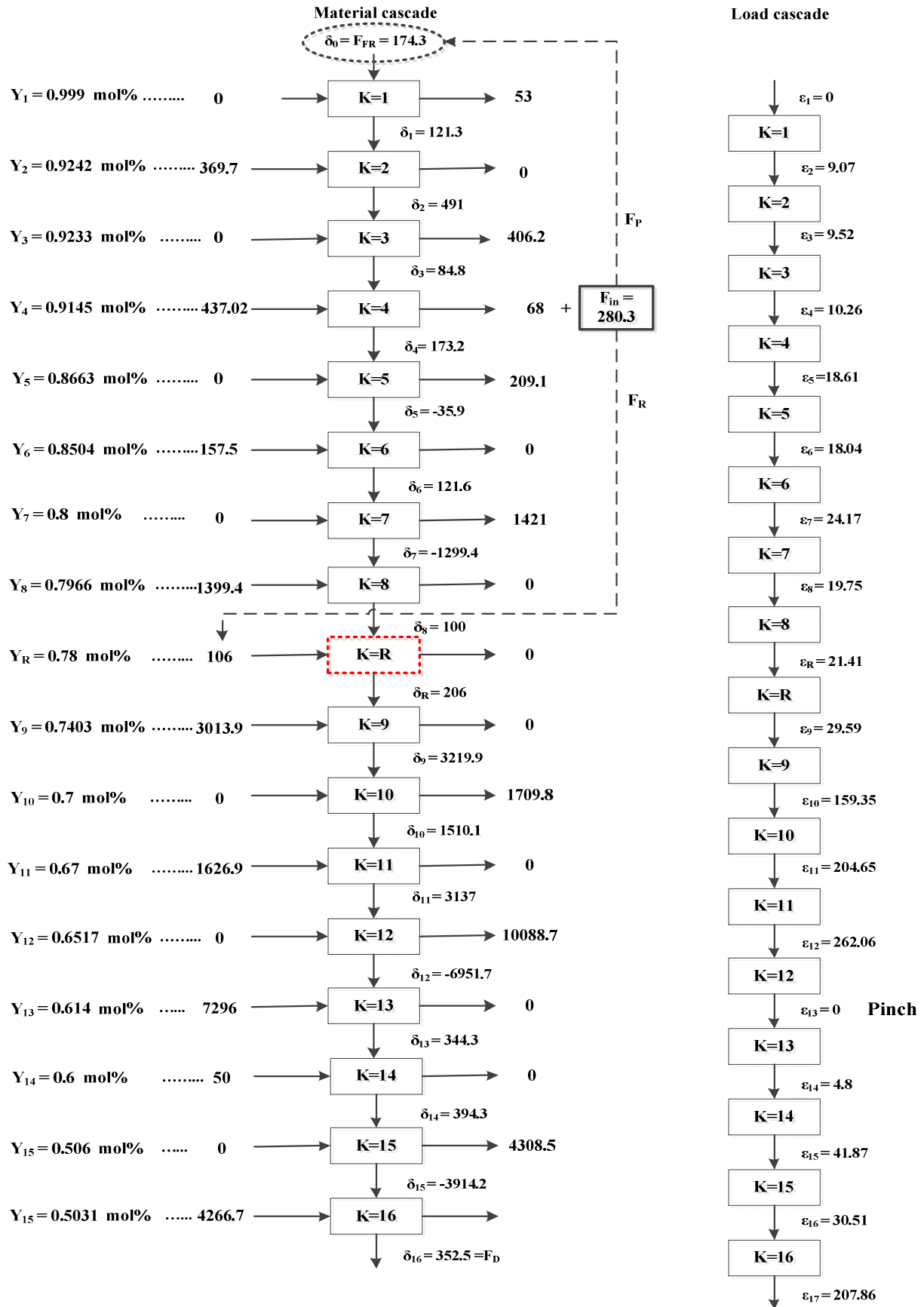

Fig. 6 RCCD for case B

IV. CASE B

The hydrogen network for an ammonia petrochemical complex shown in Fig. 5 is integrated to the previous network in case A. As a matter of fact, case B consists of two petrochemical complexes. This complex includes a catalytic reformer and also an ammonia synthesize unit. So, two sources and one sink are added to the previous network. Sources/sinks data for existing network in case B are shown in table III. Modified automated targeting is again applied for new network, and the results are represented in Fig. 6. It is observed that minimum resource flow rate is further reduced. Moreover, pinch point moves to new purity level.

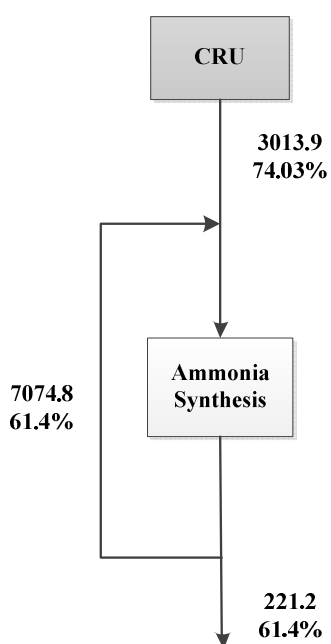

Fig. 5 Hydrogen network of ammonia complex

TABLE III
SOURCE AND SINK DATA FOR CASE B

Source		Sink	
Flow rate (mol/s)	Purity (mol%)	Flow rate (mol/s)	Purity (mol%)
369.7	92.42	53	99.9
526.4	91.45	406.2	92.33
157.5	85.04	438	91.45
1399.4	79.66	209.1	86.63
3013.9	74.03	1421	80
1626.9	67	1709.8	70
7296	61.4	10088.7	65.17
50	60	4308.5	50.6
4266.7	50.31		

As shown in Fig. 6, the minimum fresh hydrogen and waste discharge flow rates (F_{FR} and F_D) for this case are targeted as 174.3 and 352.5 mol/s, respectively, which means 24.6% reduction in fresh hydrogen consumption. The pinch purity level is moved to 61.4 mol % (Y_{13}). Therefore, it is observed that integrating these two petrochemical complexes reduces fresh hydrogen consumption even further.

V. CONCLUSION

In this study, an automated targeting approach is applied to minimize the fresh hydrogen consumption in petrochemical complexes. For cases considered here, the fresh hydrogen resource is PSA product stream. Consequently, its relative sink (PSA feed) and source (PSA residue) are changing according to the obtained target. Therefore, the automated targeting approach is modified to cope with this specific case. Having incorporated the modified automated targeting method, the results showed 16.7% reduction in fresh hydrogen consumption. Moreover, integration of two petrochemical complexes is led to more reduction (24.6%) in fresh hydrogen consumption.

NOMENCLATURE

i	index for source
j	index for sink
k	index for purity level
F_{SRi}	flowrate of SR _i
F_{SKj}	flowrate of SK _j
F_{FR}	fresh resource flowrate
F_D	waste discharge flowrate
F_{in}	PSA inlet (feed) flowrate
F_P	PSA product flowrate
F_R	PSA residue flowrate
R	purifier recovery
Y	hydrogen purity
Y_{in}	PSA inlet (feed) purity
Y_P	PSA product purity
Y_R	PSA residue purity
δ_k	net material flowrate from level k
ϵ_k	residue of the hydrogen load at level k

PSA.....	pressure swing adsorption
HG	hydrogenation
HT	hydrotreating
IS	isomerization
TA	transalkylation
DP	disproportionation
RG	regeneration
AF	arofining

REFERENCES

- [1] Alves, J.J., Towler, G.P., "Analysis of refinery hydrogen distribution systems," *Industrial & Engineering Chemistry Research* 41, pp. 5759–5769, 2002.
- [2] El-Halwagi, M., Gabriel, F., Harell, D., "Rigorous graphical targeting for resource conservation via material recycle/reuse networks," *Industrial & Engineering Chemistry Research* 42, pp. 4319–4328, 2003.
- [3] Foo, D.C.Y., Mannan, Z.A., "Setting the minimum utility gas flowrate targets using cascade analysis technique," *Industrial & Engineering Chemistry Research*, vol. 45, pp. 5986–5995, 2006.
- [4] Hallale, N., Liu, F., "Refinery hydrogen management for clean fuels production," *Advances in Environmental Research* 6, pp. 81–98, 2001.
- [5] Liu, F., Zhang, N., "Strategy of purifier selection and integration in hydrogen networks," *Chemical Engineering Research & Design*, vol. 82, pp. 1315–1330, 2004.
- [6] Ahmad, M.I., Zhang, N., Jobson, M., "Modelling and optimisation for design of hydrogen networks for multi-period operation," *Journal of Cleaner Production*, vol. 18, pp. 889–899, 2010.
- [7] Ng, D.K.S., Foo, D.C.Y., Tan, R.R., "Automated targeting technique for single-impurity resource conservation networks. Part 1: Direct reuse/recycle," *Industrial & Engineering Chemistry Research*, vol. 48, pp. 7637–7646, 2009a.
- [8] Ng, D.K.S., Foo, D.C.Y., Tan, R.R., "Automated targeting technique for single-impurity resource conservation networks. Part 2: Single-pass and partitioning waste-interception systems," *Industrial & Engineering Chemistry Research*, vol. 48, pp. 7647–7661, 2009b.
- [9] M. M. El-Halwagi, V. Manousiathakis, "Automatic Synthesis of Mass-Exchange Networks with Single Component Targets," *Chem. Eng. Sci.*, vol. 9, pp 2813-2831, 1990.
- [10] Brooke, A., Kendrick, D., Meeruas, A., Raman, R., *GAMS-Language Guide*. GAMS Development Corporation, Washington, D.C., 2006.



Mostafa Shariati was born in Tehran, Iran in 1987. He received his Bachelor degree in chemical engineering from Amirkabir University of Technology, Tehran, Iran, in 2009. He is currently an M.S. student in chemical engineering at the University of Tehran, Tehran, Iran and working on hydrogen management in petrochemical complexes via pinch analysis and mathematical optimization. Mr. Shariati is interested in process design and integration and would like to pursue his study in this field.



Nassim Tahouni was born in Tehran, Iran in 1975. She studied her Bachelor degree in chemical engineering at Sharif University of Technology, Tehran, Iran and the Master and Doctoral degrees in chemical engineering at the University of Tehran, Tehran Iran. Nassim Tahouni earned her Ph.D. in 2008. She is now assistant professor of Chemical Engineering at the University of Tehran, School of Chemical Engineering. She has carried out many research projects as well as consultancy services in the fields of Process Integration, Energy and Environment. Dr. Tahouni is a member of Iranian Association of Chemical Engineering and also Iran Energy Association. She has been working in the field of Process Integration over the past 12 years, mainly dealing with Process Design & Optimization, Retrofit of Process Industries, Sub-ambient Systems and Low-temperature Separation. She has also published more than 25 papers in scientific journals and conference proceedings.



Ahmad Khoshgard was born in Tehran, Iran in 1965. He studied his Bachelor degree in chemical engineering at Amirkabir University of Technology, Tehran, Iran and his Master in chemical engineering at Sharif University of Technology and Doctoral degree in Energy Engineering at the Islamic Azad University, Tehran, Iran. Ahmad Khoshgard received his Ph.D. Degree in 2005. He is now teaching chemical engineering subjects in Islamic Azad University, South Tehran Branch, Iran. Also, he is with National Petrochemical Company of Iran in which he has gained extensive industrial experience. Dr. Khoshgard is interested in Heat Transfer, Thermodynamics and Process Integration, about which he has published many papers in journals and conference proceedings.



M. Hassan Panjeshahi was born in Tehran, Iran in 1957. He studied his Bachelor degree in chemical engineering at Sharif University of Technology, Tehran, Iran and the Master and Doctoral degrees in chemical engineering at the University of Manchester, Manchester, UK. Hassan Panjeshahi earned his Ph.D. in 1991. He is now a professor of Chemical Engineering at the University of Tehran, School of Chemical Engineering, and also adjunct professor in the Department of Chemical and Petroleum Engineering, University of Calgary, Canada and visiting professor in the Department of Chemical Engineering, Universiti Teknologi Petronas. Between 2003 and 2008, he was chancellor of the Petroleum University of Technology in Iran. Professor Panjeshahi is currently a member of editorial board of eight scientific journals and also member of several scientific societies, associations and institutions, including Iran Academy of Sciences. He is the founder and the first president of the Iran Energy Association and also the founder and the first Editor-in-chief of the Iranian Journal of Energy affiliated to the World Energy Council. Prof. Panjeshahi has been working in the field of Process Integration over the past 23 years, mainly dealing with Process Optimization, Energy Conservation, Emission Reduction, Water and Waste Water Minimization in Process Industries. He has done many consultancy services for different process industries and also carried out numerous applied research projects in different aspects of Process Integration. He has also published more than 110 papers in scientific journals and conference proceedings.